

NEW — BIGGER SCOPE — MORE PAGES

TELEVISION

THE FIRST TELEVISION JOURNAL IN THE WORLD

and **SHORT-WAVE WORLD**

MONTHLY 1/-

FEBRUARY 1935

BERNARD JONES PUBLICATIONS LTD.,
58-61 FETTER LANE, LONDON, E.C.4

TELEVISION

A Forecast

New Systems, Inventions, etc.

Practical Notes and Advice

Beginners' Section

*Building New Mirror-drum
Receiver*

etc., etc., etc.

SHORT WAVES

The B.E.R.U. Contest

*Building I—V—I Band Spread
Receiver*

*Ultra-short Wave
Experimenting*

*Multi-electrode Frequency
Changers*

Short-wave World Review

etc., etc., etc.





Purveyors of
Electric Lamps
By Appointment

EDISWAN



Manufacturers
and Purveyors
of Electric Lamps
By Appointment



Ediswan Ray Tube
Price £8.0.0

Ediswan Mercury Vapour
Relay. Price £1.15.0

Ediswan MR/AC, I gas
discharge triode for use
in sweep circuits
associated with the
tube.

HIGH VACUUM CATHODE RAY TUBES

This new high vacuum device supplies the need for a tube of long life and improved modulating characteristics suitable

for
and
**TELEVISION
RADIO RESEARCH**

We invite enquiries for :

- Mercury Vapour Rectifiers.
- Grid controlled discharge tubes for time bases.
- High Vacuum Diodes.
- Transmitting Valves, low and medium powers.

Full information on the tube and its associated circuits can be obtained on application to the Technical Service Dept. at the address below.

EDISWAN RADIO VALVES

THE EDISON SWAN ELECTRIC CO. LTD.



155 CHARING CROSS ROAD, LONDON, W.C.2

USED BY ALL GOVERNMENT DEPARTMENTS

HIGH DEFINITION FILM TELEVISION TRANSMITTERS

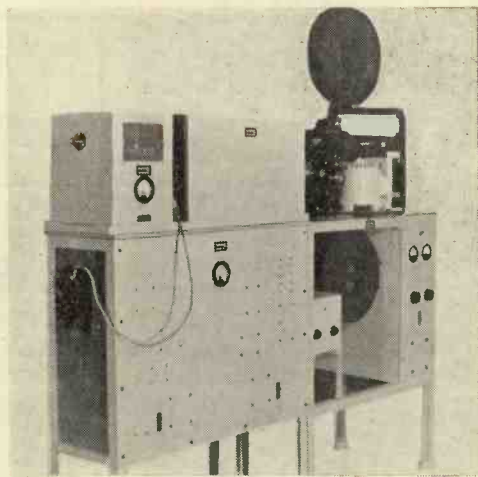

Manufactured by
SCOPHONY LIMITED

The transmitters incorporate the Scophony special optical patents, which make it possible to obtain adequate light on the photo cell, using only a small filament lamp as light source.

SCOPHONY LIMITED, DEAN HOUSE, 2, DEAN STREET, LONDON, W.1.

GERRard 1228

Specified by  the Experts.
SOUND SALES

A deep Depression

A DEEP DEPRESSION centred over Radiolympia in 1933, spread slowly but surely over the Radio trade far into 1934. This caused many unfortunate firms to fall out of the industry and yet the completed Annual Audit of Sound Sales, Ltd., shows increased business during the depression. We respectfully suggest that this is due to the fact that a greater number of discriminating Home Constructors have realised that SOUND SALES products—which include Mains Transformers, Chokes, L.F. and Output Transformers, are better than the advertisement, also that the majority of Radio Manufacturers depend on SOUND SALES never to let them down or jeopardise their Goodwill, by supplying them with anything but the best Mains Transformers, Chokes, etc.

IN ADDITION, the G.P.O. together with numerous Talking Film Concerns and Television Companies, pin their faith on SOUND SALES; in other words, the name of SOUND SALES has a very effective double meaning, that is greatly enhanced by the performance of their Type 30 v. Chokes which were specified for the "Television Power Amplifier" described in the January issue of "Television."

May we give you details of all our products?

SOUND SALES LTD.,

Contractors to the G.P.O. etc.

TREMLETT GROVE, JUNCTION ROAD, LONDON, N.19.

Telephone—Archway 1661/2

Use a **W.X.6. WESTECTOR**
in your television receiver
and you will get better,
clearer and positive
pictures.

Use a

 **WESTINGHOUSE** 

METAL RECTIFIER
in your power pack, and you will
get a constant undeteriorating
HIGH TENSION SUPPLY AS WELL

The Westinghouse Brake & Saxby Signal Co., Ltd.,
82, York Road, King's Cross, N.1.

IMPORTANT NOTICE TELEVISION ENTHUSIASTS

. . . . DON'T MISS THIS !!
MERVYN COMPONENTS are **EXCLUSIVELY**
USED AND SPECIFIED

A REVELATION IN WIRELESS RECEIVERS

THE NEW FARADAY

ALL WAVE
SUPERHETERODYNE
15 Meters to 2,000.

True Single Control Tuning. No hand capacity troubles. Full A.V.C. Low interstation noise Level. Extremely high quality reproduction.

A GENUINE WORLD SET

Hear U.S.A., Australia, etc., direct on the loudspeaker.

FARADAY BOOKLET

giving interesting short wave information and testimonials from users in various parts of the world.

FREE ON REQUEST.

A MERVYN PRODUCTION

for the
**SPECIAL DOUBLE IMAGE
KERR CELL MIRROR
DRUM RECEIVER**

*described and illustrated on page 53
of this issue.*

This High efficiency small Compass Set includes

**THE MERVYN
DUO-SPHERE
MIRROR DRUM**
the latest and most advanced of
Mervyn productions.

Only 3½" in diameter. Scientifically balanced and adjusted ready for use.

**A really high grade scientific
engineering production.**

*Write for full details of the components
used in this revolutionary receiver.*

SHORT WAVE COMPONENTS

Those interested in Short Wave Reception Components should write for current List of items in stock and Details of High Grade, popular priced Convertors, Coils, and other apparatus

TO BE ANNOUNCED SHORTLY.

THE POPULAR MERVYN TELEVISION SET

**PICTURES IN THE
HOME for 60/- ONLY**

Thousands of Kits already sold.

**EASILY ASSEMBLED—DEFINITE
RESULTS.**

Read this extract from unsolicited Testimonial:—

Lancs.
I posted my order for a "Mervyn 60/- Television Kit" early on Wednesday morning, and had received and assembled the Kit by noon on Thursday (kindly note I live over 200 miles from London). Next I congratulate you on the value of the set. I have tested it out thoroughly, and must agree with the statement in your advertisement—"it definitely brings pictures into the home."

List of parts included:—

- | | |
|--|------|
| (1) 1 B.D. 4-Disc 15½ in. diameter | 6/- |
| (2) 1 B.M.3 Universal Motor | 20/- |
| (3) 1 pair Motor Brackets | 5/6 |
| (4) 1 Variable Resistance | 6/6 |
| (5) 1 Fixed Resistance | 4/- |
| (6) 1 Lampholder | 9d. |
| (7) 2 pairs of Terminals and Blocks | 2/- |
| (8) 1 Mervyn Duplex Nu-Glo 16
Lamp (maximum brilliance
with low-current value) | 12/6 |
| (9) Baseboard Parts | 3/6 |

**PRICE
OF
PARTS** **£3** Complete

**THE FINEST
VALUE OBTAINABLE**

*Write for advice and details of Television and Radio apparatus, or any
component part you may require to:*

**THE MERVYN SOUND & VISION
COMPANY - - - LIMITED**
4 HOLBORN PLACE, LONDON, W.C.1

Managing Director: **W. J. NOBBS.**

Telephones: **Holborn 6332 and 7709.**

French Office: **8 Square Henri-Delormel, Paris 14e.**

MERVYN FOR RELIABLE TELEVISION COMPONENTS & SOUND APPARATUS

When replying to advertisements, please mention "Television"

TELEVISION

and SHORT-WAVE WORLD

Special Features in this Issue

	PAGE
A Midget Mirror-drum Receiver ...	53
The Peck Transmitter and Receiver ...	57
The B.E.R.U. Short-wave Contest ...	59
American Amateur Radio Practice ...	60
The B.B.C. Test Transmissions ...	62
The Relative Efficiencies of Mirror-drum and Disc Receivers ...	63
The First Kerr Cell ...	67
An Ingenious Speed Control ...	70
The 1-V-1 Band-Spread Receiver ...	71
Multi-electrode Frequency Changers ...	75
The Short-wave Radio World ...	77
The Importance of the Amplifier ...	79
Recent Television Developments ...	81
An Experimental High-definition Television Receiver ...	84
The Physical Society Exhibition and Television ...	92
Modern High-definition Television ...	95
A "Triggered" Synchroniser ...	97
The Simplest Cathode-ray Receiver ...	99
Heard on the Short Waves ...	104

COMMENT OF THE MONTH

The Television Committee's Report

IN the interests of our readers we have held this issue of TELEVISION AND SHORT-WAVE WORLD from the press until the latest possible moment so that we might have an opportunity of incorporating in it a summary and the salient points of the Television Committee's eagerly awaited report. This summary will be found on four tinted pages incorporated in this issue, which pages have been added to our issue at the very last moment of going to press. We have no time nor space in which to comment as we should like to do upon the report. All that is possible at the moment is to draw attention to one or two pleasing features.

Everybody will be glad that the Committee considers that a public service of high-definition television should be established in the near future, and that the 30-line broadcasts should be maintained for the present. It feels that the B.B.C. should be entrusted with the broadcasting of television and that ten ultra-short-wave transmitting stations would serve at least fifty per cent. of the population. It recommends the pooling of television patents and that Baird and Marconi-E.M.I. should supply transmitting apparatus for the operation of their respective systems at the London station, the systems operating alternately. The cost of the service during the experimental period should come from the existing 10s. broadcast licence fee.

The Report can be regarded as television's charter. Television has made progress slowly, perhaps painfully, but certainly surely, but it will soon get into its stride and we are confident that it will progress at such a speed as rapidly to make history.

Our Larger Scope

Number of Pages Permanently Increased

WITH this issue we extend the sphere of usefulness of this Journal. In future it will cover television and short-wave working. The reason for this can be explained in a few words—there is not a shadow of doubt but that the future of television lies with short waves and we believe that we can best encourage and assist development by fostering a greater interest in short-wave work.

In order to do this we hope to enlist the interest of the many thousands who are engaged in short-wave working, many of whom have contributed so largely to the progress that has been made. For this reason we propose covering every side of short-wave working and providing for this staunch band of enthusiasts information which hitherto has not been available in this country. TELEVISION AND SHORT-WAVE WORLD (the new title) will actually be two journals in one with a strong linking up of the allied subjects.

We wish to emphasise the fact that the number of pages has been permanently and very considerably increased, so as to allow of our devoting ample space to all the interests covered by our new title; and as television and short-wave radio increase in importance, as they are bound to do in the very near future, so our readers can be assured that there will be a corresponding increase in the number of our pages.

TELEVISION AND SHORT-WAVE WORLD

Proprietors:

BERNARD JONES PUBLICATIONS, LTD.

Editor-in-Chief:

BERNARD E. JONES.

Editor:

H. CORBISHLEY.

Editorial, Advertising and Publishing Offices:

58-61, Fetter Lane, London, E.C.4.

Telephone: Central 4341 (four lines).

Telegrams: Beejapee, Fleet, London.

Subscription Rates: Post paid to any part of the world—3 months, 3/6; 6 months, 6/9; 12 months, 13/6.

Published Monthly—1/- net.

(Last Wednesday in every month for following month).

Contributions are invited and will be promptly considered. Correspondence should be addressed according to its nature, to the Editor, the Advertisement Manager, or the Publisher, "Television," 58-61, Fetter Lane, London, E.C.4.

The Future of the Short Waves

From Noel Ashbridge, Chief Engineer of the British Broadcasting Corporation.

THE greatest interest the British Broadcasting Corporation has in short waves at present is the British Empire transmission from Daven-try. The system is immensely success-ful and remarkable distances are covered. There is a growing trend in Great Britain at present towards tuning-in on foreign short-wave stations and this movement is being exploited and fostered by radio manufacturers.

The American trend is now being followed and it is quite certain that interest in short-waves will very shortly reach a point where a huge proportion of British listeners will be tuning-in American short-wave features as easily as American listeners are now tuning-in the British programmes.

* * *

From John Clarricoats, G6CL, Secretary of the Radio Society of Great Britain.

Congratulations upon producing for the first time in this country, a commercial journal devoted to short-wave radio work.

The fact that this journal is now in being is direct evidence that a demand exists for a popular periodical devoted to the subjects mentioned in its title—a most healthy sign of the times.

For nearly 22 years the R.S.G.B. has fostered, by every means within its power, interest in amateur radio, and during that time it has sponsored many developments in the art of electrical communications. Of late, however, its members have been seriously handicapped in their experiments (particularly on short and ultra-short waves), by the lack of suitable valves and components. Their needs have to some extent been met by the use of foreign material, but such substitutes are unsatisfactory from a British point of view, however good they may be in a technical sense. I hope that due consideration will be given to this matter by those responsible for this journal.

Of the future I would say, get to know all that is to be known about the ultra high frequencies, because I feel that it is in that part of the frequency spectrum that the biggest developments will take place. But a word of warning; if short-wave work is attracting attention for the first time, a knowledge of the circuits used and phenomena experienced on the lower frequencies, is imperative before ultra-short waves are investigated.

On numerous occasions the question has been asked "Why does the R.S.G.B. not include details of 5-metre apparatus in its Guide to Amateur Radio?" The answer is a simple one; the guide is an

Some Expert Opinions

excellent introduction to amateur radio, but no place, as yet, for information dealing with a subject which experienced amateurs are still unable fully to understand.

The necessity of obtaining a Govern-ment licence to carry out transmitting tests, has in the past not been suffi-ciently stressed in certain quarters, but this requirement is essential however simple the apparatus may be.

Finally, may I emphasise that in all experimental work co-operation is of the utmost importance, and it is for this reason, more than any other, that the R.S.G.B. has organised its Research and Experimental Section.

Wishing your new venture every suc-cess.

* * *

From R. D. Everard, a well-known short-wave amateur.

I am glad to hear that you are pub-lishing a new journal, devoted to tele-vision and the short waves. Such a journal is badly needed, particularly one that contains up-to-date reception reports and interesting instructional articles for the experimenter. There is no doubt that short waves and tele-vision are the coming vogue. Short-wave reception offers so much of inter-est from the four corners of the earth and one never knows exactly what one is going to hear.

These combine to make short-wave radio a hobby of unrivalled interest, both from the listening and transmitting sides with its constant joy of construc-tion and experimenting.

Wishing you every success.

* * *

From Sir Ian Fraser, O.B.E., M.P., Chairman of St. Dunstons.

I am most interested to hear of the new publication and wish it luck. I should be happy for you to print the following brief message from me if you thought it would be of any interest or service.

"Good luck with the new publica-tion—TELEVISION AND THE SHORT WAVE WORLD. I hope this year will see television developments which will be of great interest to the amateur, expert and to the trade. I think the amateur experimenter renders a most valuable service, aiding technical development and familiarising a wider circle with technical knowledge. I feel sure your new journal will help workers and stu-dents in this very interesting field."

From Gerald Marcuse, 2NM, First Vice-President International Amateur Radio Union.

I consider that up till now the general public has been starved of any lead in short-wave work.

Television and ultra-short waves have an immense future, and it is high time that more details should be published. I have not much knowledge of tele-vision, but am certain that in ultra-short waves lies the future of broadcast-ing vision and sound as also world-wide communications.

* * *

From J. E. Nickless, V A.M.I.E.E., G.2K.T., one of the best known and oldest transmitters.

I am greatly interested to learn you are about to launch a new publication dealing with television and short wave H.F. communication.

I feel sure that such subjects dealt with in your capable hands should meet with the success you deserve.

I am looking forward to the first pub-lication with great interest.

Wishing you every success in your new enterprise.

* * *

From H. Bevan Swift, A.M.I.E.E., Past-President of the Radio Society of Great Britain.

I hear with great interest that you are about to publish a paper devoted to television and short-wave radio. There is no doubt that these are the most in-tensive features of interest in the radio world to-day and a paper specialising in this respect will meet a much felt need.

The many workers in the interests of television alone would benefit in the notices of the work and lead no doubt to co-ordination of work and the avoid-ance of much repetition in experimental work in already well-explored fields.

The subject of short-wave radio is always an interesting one and much still remains to be done in this import-ant field. I wish the journal every possible success and shall watch its pro-gress with interest.

* * *

From Arthur E. Watts, G6UN, Presi-dent of the Radio Society of Great Britain.

I am interested to learn that you are about to publish the first number of TELEVISION AND SHORT-WAVE WORLD.

I wish you success in your undertak-ing, and if your journal is able to con-tribute to our knowledge of the short-and ultra-short waves, I feel sure it will be successful.

A MIDGET MIRROR-DRUM RECEIVER

THE FIRST
RECEIVER
USING A 3½-IN.
DRUM AND
DOUBLE-IMAGE
PRISMS

By
R. L. Ashmore

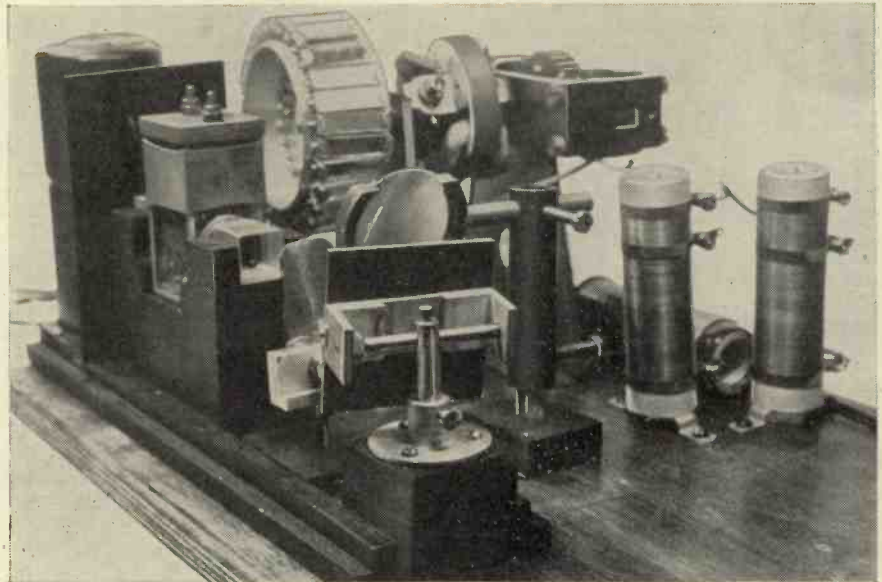

The receiver described in this article is unique, it being the first of its type to employ a small drum scanner made possible by scientific design. Our personal tests have proved that with a lamp of only 32 watts a remarkably bright picture of standard size was obtained. The designer has had many years of practical experience of mechanical scanner design and the article will be found most informative.

RECENT improvements in light valves and a better understanding of the optics of mirror-drums, enable a mirror-drum receiver to be designed now that is very much smaller and yet more efficient than those designed, say, a year or two ago.

The improvement in light valves referred to is the

Double - image Kerr Cell, the theory of which has been explained in earlier issues. Briefly the double - image Kerr cell makes use of both the ordinary and extraordinary rays emanating from the double-image prism. The exit angle is not limited and there are no losses other than absorption in the calcite, the lenses and nitro - benzene. The total absorption does not amount to more

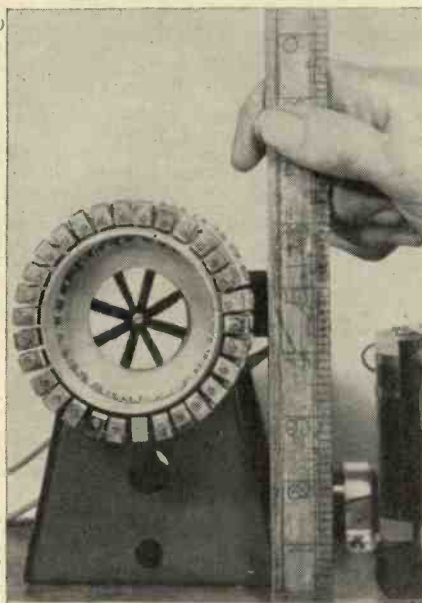

The small size (actually 3½ in. diameter) of the mirror drum will be apparent from this photograph.

than 35 per cent. This compares very favourably with the older Nicol prism type of Kerr cell where the losses were of the order of 90 per cent.

We may take it that a double-image Kerr cell will give approximately three times more light than the older version using the same source of light.

Let us consider for a moment how this increase in light helps us in the design of the mirror-drum and its associated optical system. The brightness of the mirror-drum picture is given by the formula

$$I = \frac{16\pi \times e \times M}{A \times p^2}$$

where I is the screen intensity in Hefner candles per cm.²; e is the surface brightness in Hefner candles per cm.² of the light source or light valve; M is the area of one mirror in the drum (height × width), A is the picture area in cm.², p is the number of picture elements.

If one wishes to convert the result into lux the result must be multiplied by 10,000 × π. Furthermore the optical losses such as absorption must be subtracted from the result of this formula. It will be noted that the brightness of the picture depends on the number of picture elements and not on the number of lines.

Let us take the concrete case of a 30-line mirror-drum with a double-image Kerr cell. First, we must substitute for e. Due to the peculiar optical system of the double-image Kerr cell, which will be discussed later, it is impossible to use a bunched filament lamp of the 12-volt 100-watt type which is used with ordinary

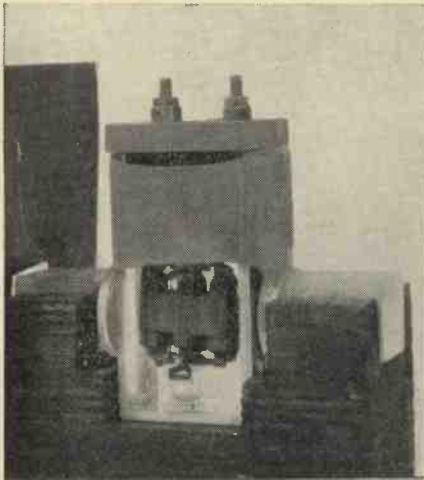

The Kerr cell is contained in a glass box; on either side will be observed the double-image prism with lenses attached.

Kerr cells. A very much smaller concentrated source of light must be used and as will be seen later this actually helps us in reducing certain distances in the optical layout. The author tested about a score of different types of small lamps and it was found that the 8-volt 4-amp. 32-watt "talkie" exciter lamp which is manufactured by all the ring lamp manufacturers gave the best results. This lamp is cheap and will stand a considerable amount of over-running. The brightness of this lamp when slightly over-run is approximately 1,600 HC cm.².

Taking into consideration the losses in the Kerr cell we get a figure of approximately 1,050 HC cm.² out of the Kerr cell. Therefore $e = 1,050$.

The factor M can be reduced considerably by the dimensions generally used as the factor e is higher than hitherto. In the Baird mirror-drum $M = 10.5$ sq. cm. In the Mervyn mirror-drum it is slightly less. Both these drums are known to give good results with an ordinary Kerr cell and 100-watt lamp. As we have more light available to start with we can reduce our mirror area to 3 sq. cm., taking a mirror 1 cm. wide and 3 cm. long which gives a drum diameter of less than 9 cm., namely, about $3\frac{1}{4}$ ins.

LIST OF COMPONENTS

- | | |
|---|---|
| 1 small unisphere mirror drum with 1 cm. mirrors (Mervyn). | 1 plano convex lens $1\frac{1}{2}$ in. diameter, $3\frac{1}{2}$ in.—4 in. focal length. |
| 1 type BM ₃ motor (Mervyn). | 1 Kerr cell aperture 28-30 thou. (Mervyn). |
| 1 angle mirror (Mervyn). | 1 glass box 3 x 3 cms. (Griffin & Tatlock). |
| 1 8-volt 4-amp. 32-watt exciter lamp (Philips, G.E.C., Mazda). | 2 fixed resistances 700 ohms (Mervyn). |
| 1 holder for same (G.E.C.). | 1 variable resistance 150 ohms (Mervyn). |
| 2 double-image prisms (Mervyn). | Motor brackets (Mervyn). |
| 2 achromatic lenses $\frac{1}{2}$ in. diameter $1\frac{1}{2}$ in.—2 in. focal length. | 1 lamp transformer mains; primary 8 volts, 4 amps. Secondary with tapings at 8, 9 and 10 volts (Partridge). |
| | 1 coil screen for lamp house (Colvern). |

We will take A, the picture area, as 3 x 7 ins., namely, 21 sq. ins., which is approximately 120 sq. cm.; $p = 2,100$ elements, therefore $p^2 = 4,410,000$; $16\pi =$ approximately 50.

Substituting the various factors in the formula we

$$\text{get: } I = \frac{50 \times 1,050 \times 3}{120 \times 4,410,000} = \frac{1}{3,360} \text{ HC cm.}^2$$

which equals approximately 9.5 lux.

We have one lens and one reflection which together

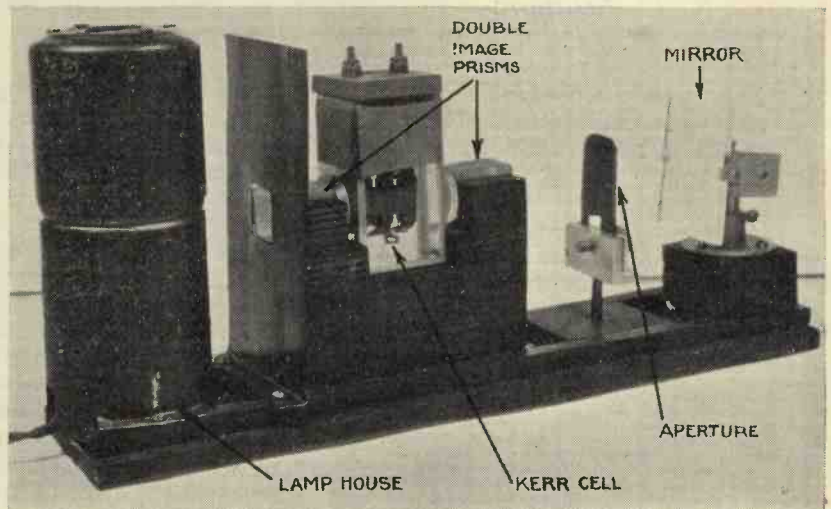

A photograph of the optical unit.

absorb about 19 per cent. of this quantity of light, leaving us with a screen brilliance of just over 7 lux, which is extremely good for a television picture. For

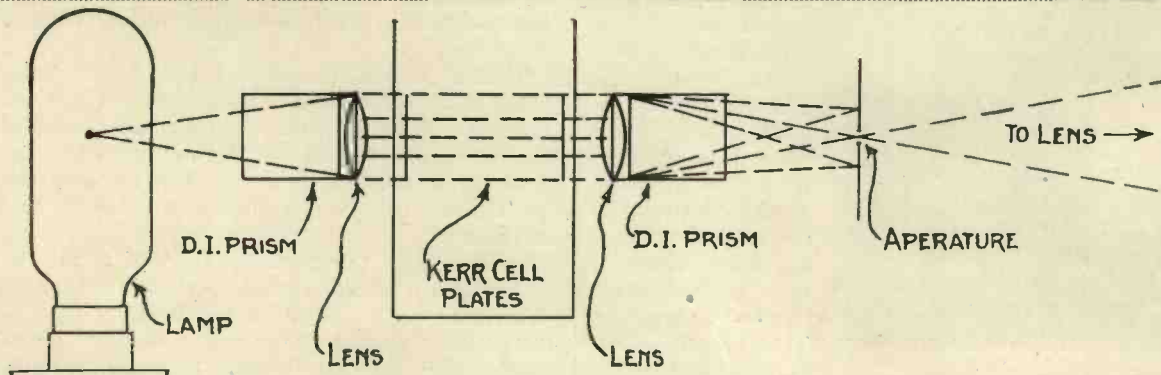

Fig. 1. The optical train of the Kerr cell.

FEBRUARY, 1935

the sake of comparison a 30-line disc image with an Osglim lamp has a brightness of 1.5 lux.

We see, therefore, that the use of the double-image Kerr cell enables us to use a mirror-drum of about 3 ins. diameter, which is smaller than anything that was possible hitherto. As our moving part is small it remains for us to design the rest of the optical system for the receiver in a compact way.

We have two more important formulæ to consider. First we have the formula which determines our pic-

$$v = \frac{B(t - f)}{K n f}$$

where t is the distance between the lens and the aperture and K is the picture ratio.

Inversely, provided we know the value of v , the aperture size, we can determine the focal length of the lens.

On the other hand if we know both the focal length of the lens and the aperture size, we can determine t from the formula:

$$t = f \left(\frac{K n v}{B} + 1 \right)$$

In this particular case we are at liberty to choose t or f because the factor v , the aperture size, is determined by the filament shape of the exciter lamp used as light source. Fig. 1 shows the optical system of the Kerr cell. It will be seen that an intermediate image of the filament is made on the aperture. We must fill the whole of the aperture with light and therefore the aperture must not be greater than the image of the filament on it. The limit is about 28-30 thousandths of an inch.

This aperture is easy to obtain as it happens to correspond to the size of punch used in 20-inch scanning discs having 30 holes.

Now that we have determined v at 30 thousandths of an inch we can determine f . This works out at approximately $3\frac{1}{2}$ ins., but this figure is not very critical because by altering t , the distance between the aperture and the lens, we can make up for slight differences in the focal length of the lens. We must only be careful that t is slightly greater than f , that is, the distance between the lens and the aperture must be greater than the focal length of the lens so that the beam coming out of the lens is in a slowly converging state.

If t were equal to f we would produce parallel light and would need a second lens after the mirror-drum for focusing on the screen.

If t were smaller than f we would produce constantly diverging light and would also have to use a lens after the drum.

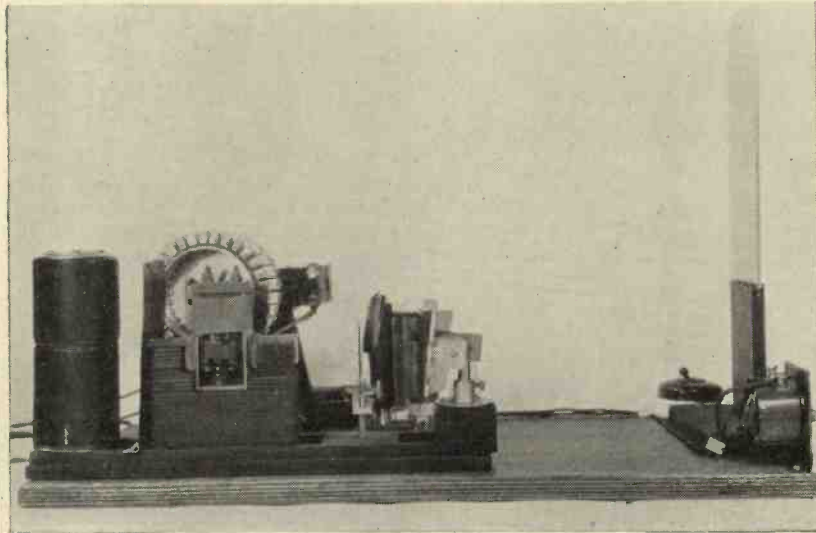

A view of the complete receiver mounted on a baseboard.

ture size; namely, $o = \frac{B \times n}{4\pi}$, where o = the distance from the screen to the mirror-drum, B is the picture breadth, namely, 7 ins., and n is the number of lines, namely, 30.

$$o = \frac{7 \times 30}{12.5} = 16\frac{1}{2} \text{ ins. approximately.}$$

We see, therefore, that the distance from the drum to the screen depends only on the picture breadth, and on the number of lines, and is in no way dependent on the focal length of the lens used in the projection system. The focal length of the lens (f), however, determines the size of our Kerr cell aperture (v), namely,

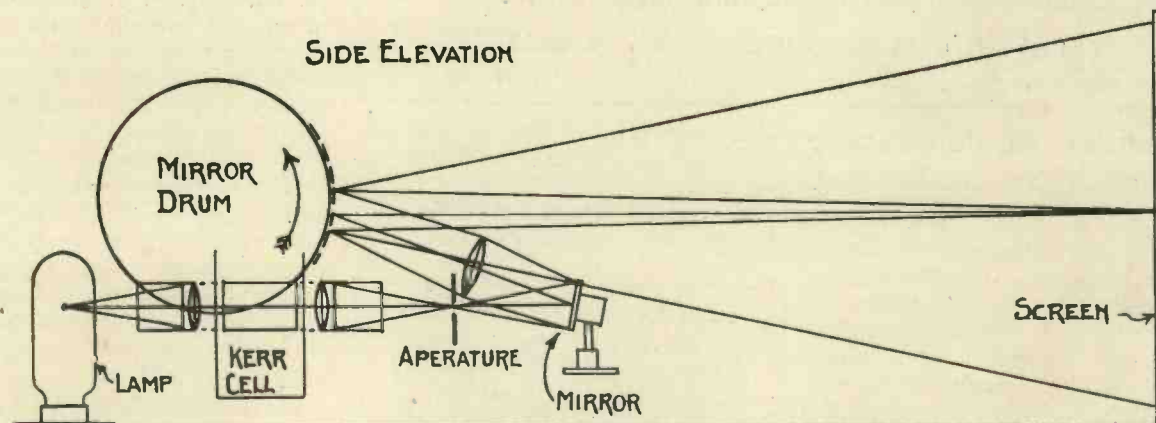

Fig. 2. A side elevation showing the arrangement of the parts and the path of the light.

Both these optical methods are unnecessary and undesirable with a receiver of this kind although under certain other conditions they may be useful.

The focal length of the lens is a direct function of the aperture size, that is, if we diminish the aperture size we could correspondingly diminish the focal length of the lens. There is, however, a limit to this which is the numerical aperture of the lens, and as the lens must be about $1\frac{1}{2}$ ins. in diameter and 3 ins. focal length we already approach a numerical aperture of 1:2, which is about the limit for uncorrected lenses if we wish to avoid aberration.

Summing up, therefore, we take v , the aperture size,

view. Extreme care should be taken to keep the angle of incidence in the plan view as small as possible as a great angle in that direction will cause the drum to scan in the manner of the Nipkow disc, namely, in arcs. In a very slight degree this is not disturbing, but if exaggerated other optical errors such as trapezoid-shaped images may occur.

It should be noted that the optical layout, as shown in Fig. 1, is not to scale and we do not propose to bind the experimenter down to certain dimensions as regards layout. This article is intended rather to be an indication of how such a receiver could be built, and the photographs show the actual model constructed.

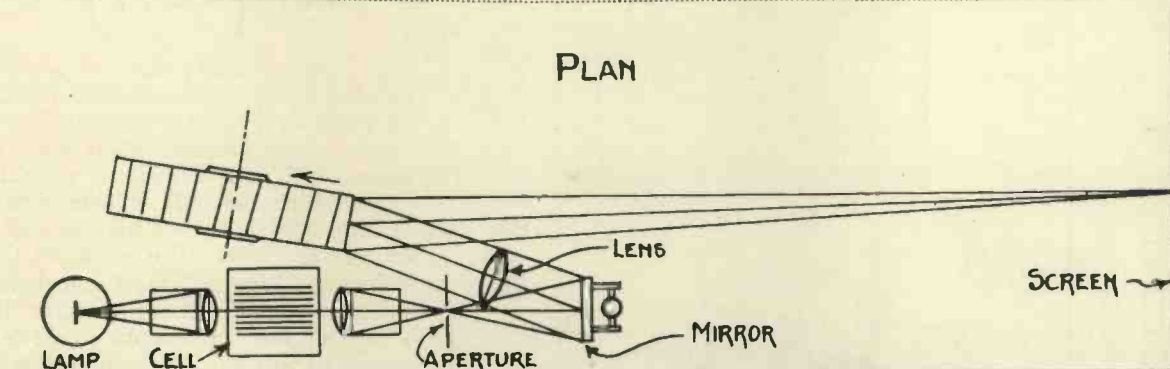

Fig. 3. A plan view showing the layout and approximate positions of the components.

as 30 thousandths of an inch, $t = 4\frac{1}{2}$ ins. approximately, and $f = 3\frac{1}{2}$ ins. approximately. Thus we get a very compact optical arrangement which can be still further reduced by the use of an angle mirror as has been done in this receiver (see illustrations, Figs. 2 and 3).

It will be seen that in this arrangement it was not practicable to arrange the mirror drum to be directly above the Kerr cell. The beam has in this case to be twisted not only in the elevation but also in the plan

I have purposely shown the optical calculation used in the design of such a receiver so that everybody can alter the design to suit his own needs with the help of the information shown above.

Next month the construction of the Kerr cell, which requires some care, will be described. Also some suitable circuits for use with it will be given.

In the meanwhile I would advise you to get two Iceland spar blocks cut in the direction of maximum separation. These can be obtained from the Mervyn Co.

NEXT MONTH—A SPECIAL ISSUE

Our next issue will contain a complete survey of the position of Television resulting from the findings of the Postmaster General's Committee. It will provide a complete guide to the most probable line of development and contain many informative and constructional articles.

Make sure of your copy by ordering it NOW.

TELEVISION AND SHORT-WAVE WORLD.

Permanently Enlarged.

MONTHLY 1/-

A Television Fashion Parade
The Duchess of Kent Chooses a Hat.

Recently the Baird Company demonstrated the value of television for publicity purposes. The Duchess of Kent, sitting in a room in their premises in Victoria Street, selected a new spring hat which was being demonstrated by a mannequin at the Crystal Palace.

Both the Duke and Duchess of

Kent were present and the Duchess expressed her pleasure with the experiment.

It is stated that the pictures came through with remarkable clearness.

An order placed with your newsagent will ensure regular delivery of **TELEVISION AND SHORT-WAVE WORLD**

Forthcoming Lectures on Television

At Morley College, 61 Westminster Bridge Road, S.E., on Friday evenings, 7.30 to 9.30, a course of twelve lectures on television is being given, illustrated by lantern slides, experiments and demonstrations. Fee 4s. 6d. Mr. J. J. Denton, the lecturer, will welcome newcomers on February 1, the fourth lecture of the series, as the remaining eight lectures will form an excellent introduction to the complete sessional course, which will commence in the autumn at The Borough Polytechnic, S.E.

We have received from Belling & Lee, Ltd., of the Cambridge Arterial Road, Enfield, a copy of a booklet on mains interference suppression. It describes a method of fitting a suppressor in the mains leads. Copies of this may be had free upon application to the address above and mention of this journal.

THE PECK TELEVISION SYSTEM

DETAILS OF TRANSMITTER AND RECEIVER

For the following description of the Peck television system we are indebted to "Radio-Craft," it being an abstract from an article which appeared in the December, 1934, issue of that journal. According to the author a considerable improvement has been made in the light-modulating cell, for it is stated that a picture fourteen inches square is obtained with motor-car headlamp as the source of light.

BOTH the transmitter and receiver of the Peck system incorporate many original ideas. A demonstration was recently given in New York which, it

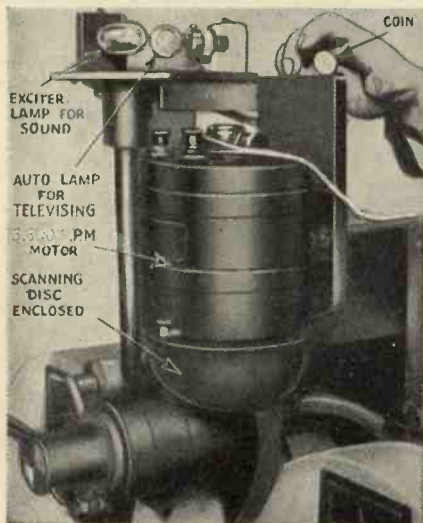

Fig. 2. The transmitter scanner is totally enclosed and is driven by a synchronous motor. As proof of the even balance a coin is shown standing on its edge whilst the motor is running.

is stated, was very successful. On this occasion a laboratory set-up utilised for simplicity a direct-wire connection between transmitter and receiver. The former consisted of a 35 mm. movie projector but, instead of the usual high-intensity arc light, a simple 6-volt, 21 candle power (automobile headlight type) lamp was employed. This more simple and economical method is made possible by the use of a special mirror-lens scanning disc (Fig. 1) which permits more than 80 per cent. of the light to be actually used.

The motor which drives the scanning disc (Fig. 2), in the receiver is a synchronous motor designed to run at 1,440 revs. per minute. This design of motor was thought necessary on the assumption that most television pictures will probably be transmitted from standard 35 mm. "talkies" film. Inasmuch as standard motion pictures are projected at

the rate of 24 "frames" or individual pictures per second, or 1,440 per minute, a synchronous motor of 1,440 r.p.m. was an absolute essential.

There are no gears whatsoever and consequently little vibration. The stability of the machine is demonstrated in Fig. 2. Running at full speed a coin remains balanced without falling off. On the extreme upper left of this photograph can be seen an exciter lamp for the sound track of the film which permitted sound accompaniment with the pictures at the demonstration. Next to it can be seen the 6-volt automobile headlight which is the only source of light employed in scanning the picture to be transmitted. The light from this lamp is focused on the respective scanning disc mirror-lens as the lens comes into the path of the rays.

The scanning disc lens then converges the beam to a point on a portion of the picture frame. Dark or light exposures on the film modulate this point of light as it passes through on its way to a photo-electric cell. From then on, it becomes a question of amplification (where the receiver is tied to the transmitter by means of a transmission line) to bring the

impulse up to sufficient strength for receiving purposes.

A satisfactory and efficient amplifier for television purposes must have a substantially flat characteristic from



Fig. 1. The transmitter scanning disc is of the lensed type.

10 to approximately 50,000 cycles (depending upon the number of scanning lines) to permit the attainment of clarity and detail in the pictures. In other words the same degree of amplification must take place at 10 cycles, as at 1,000 or 50,000 cycles. Hitherto this "straight-line" amplification has been thought only possible

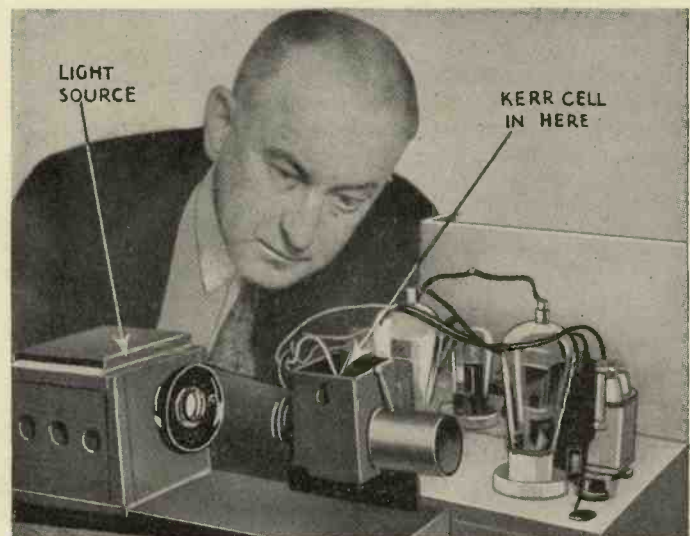

The light housing and modulator of the Peck receiver.

sible with the resistance coupling type of amplification. Mr. Peck, it is stated, has designed transformers, which he employs in his receiving amplifier (shown in Fig. 3), which have an absolutely flat characteristic up to 150,000 cycles. He states that the U.S.A. Bureau of Standards tests confirm his claim in tests and measurements which they have made up to 70,000 cycles, which was the limit of their measuring equipment. By using transformers of this design a more efficient and stable amplifier is possible, all of which, of course, results in an improved picture.

Vertical scanning at the transmitter of this system is accomplished by the continuous motion of the film; horizontal scanning, by means of 20 tubular mirror-lenses arranged in a

Kerr Cell Modulator

The light for the image, which is projected on a screen to total 14 ins. square, is also obtained from a 6-volt automobile type lamp. This is the only source of light in this television receiver and accounts for the black-on-white picture. The beam of light from this lamp is

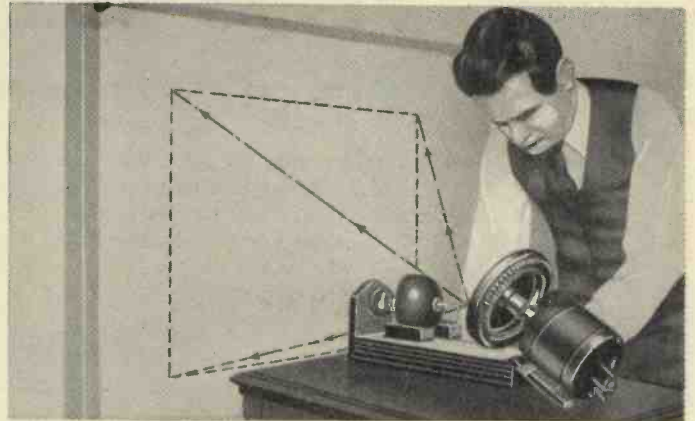

This photograph shows the shape of the projected picture and the position of the mirror-lens scanner.

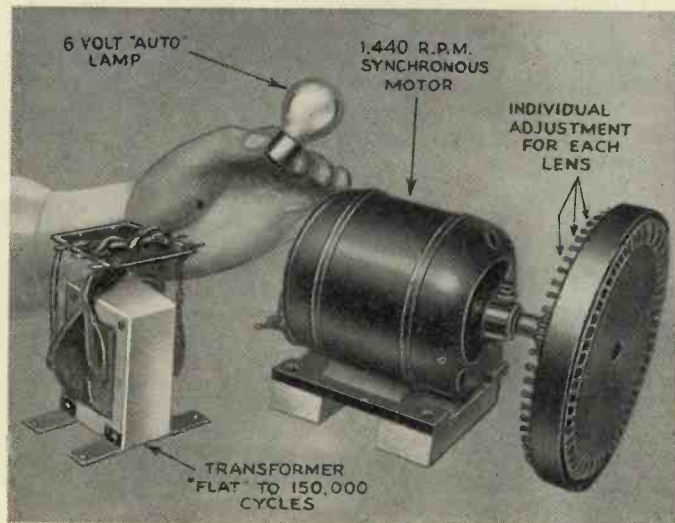

Fig. 3. The receiving motor, mirror-lens disc and special transformer. As a light source a 6-volt motor headlamp is used.

completely closed circle and rigidly mounted in a scanning disc directly connected to the shaft of a synchronous motor. One end of each tubular mirror-lens of moulded glass is silvered, as shown in Fig. 3.

Vertical scanning at the receiver is secured by loosening one screw and tightening another to rock in its mounting one of a series of half-round mirror-lenses in order to change the angles. The flat-surface area of these moulded glass mirror-lenses is silvered; scanning is obtained as the mirror-lenses, 60 in number and arranged in a completely closed circle, are rotated at 1,440 r.p.m. by direct connection to the shaft of the synchronous motor.

image is 14 ins. square, which is satisfactory for home use.

Electron Optics

The report of the December meeting of the Television Society could not be included in the January issue owing to an earlier press date than usual.

Dr. L. C. Martin lectured on "Electron Optics." Starting from first principles, it was shown that the change of direction of an electron passing the boundary surface between two equipotential regions can be described in terms of an "optical" type of law of refractive, the refractive indices occupied being num-

bers proportional to \sqrt{V} and $\sqrt{V'}$, where V and V' are the energy potentials of the electron in the two spaces. Various forms of electrostatic and

Kerr type (considerably improved by Mr. Peck), shown in Fig. 4, then focused on the mirror-lenses of the scanning disc which, by adjustment of two screws that "rock" each lens, directs and projects the spot of light to its proper position on the white screen. As previously mentioned, the size of the

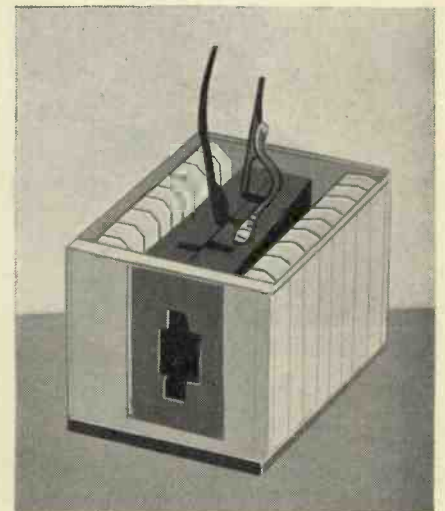

Fig. 4. The new type of Kerr cell used by Mr. Peck.

magnetic lenses were discussed and the paraxial formulæ for "thin" lenses of limited range were dealt with. It was shown that such "thin" lenses could not be given a negative power.

Finally, various applications of the above principles in cathode-ray tubes, and particularly in the "electron microscope," were described. It is possible that the method of the electron image may be ultimately used for the study of the space-lattice structure of crystals by direct images instead of diffraction patterns, and the microscopy of biological objects by such means may be possible if suitable methods for staining the structures by "heavy atom" materials can be developed.

THE B.E.R.U. SHORT WAVE CONTESTS

During February amateur short - wave transmitting and receiving stations will be taking part in the annual British Empire Radio Union contests. Valuable prizes up to £150 are to be won. Below are all the details of the contest. Entry forms can be obtained from the R.S.G.B., 53, Victoria St., S.W.1.



The photograph shows, from left to right, the Senior Trophy, the Junior Low-power Cup and the prize that can be won by the listening competitor. The small cup, which is a replica of the Senior Trophy, is retained by the winner.

The event will be divided into three sections, namely.

- (a) Senior (High Power) Transmitting Contest.
- (b) Junior (Low Power) Transmitting Contest.
- (c) Reception Contest.

Contests are open to all British subjects who are fully paid-up members of either the R.S.G.B. or the Honorary Affiliated B.E.R.U. Society in that part of the Empire in which they are resident at the time of the Contest.

A competitor not located in one of the prescribed Prefix Zones shall be considered as being in the Prefix Zone nearest to his station.

Persons holding transmitting licences may not enter for the Reception Contests.

Contacts with, or reports from, ships or unlicensed stations located in countries where licences are obtainable will not be permitted to count for points. The decision as to whether a station is to be classed as unlicensed will rest with the R.S.G.B. Awards Committee.

Only one person will be permitted to operate a specific station for the duration of any section of the Contest.

A Trophy will be awarded to the person scoring the highest number of points in each section of the Contest. Certificates of merit will be awarded to the first three stations in each Contest, and also the leading station in each Prefix Zone, providing at least three entries have been received from the zone in question.

Competitors may enter for both the Senior and Junior Transmitting Contests, but individuals are eligible to win only one of the Trophies. They will, however, be permitted to receive certificates of merit in both contests.

Entries must reach the Secretary, R.S.G.B., 53 Victoria Street, London, S.W.1, not later than April 30, 1935.

The judging of entries will be carried out by an R.S.G.B. Awards Committee,

appointed by the Council of that body. The President's decision will be final in all cases of dispute.

Rules for Reception Contest :

The Contest extends from 17.00 G.M.T. Saturday, February 2, to 17.00 G.M.T. Sunday, February 3, and will be continued from 17.00 G.M.T. Saturday, February 9, to 17.00 G.M.T. Sunday, February 10.

One point will be scored (in accordance with Rule 3 below) for each British Empire station heard working another British Empire station, providing the station heard is located outside the competitor's Prefix Zone.

Before a point can be claimed the following information must be logged :

- (a) Call of station heard.
- (b) Call of station being worked.
- (c) Entrant's report on the signals of the station heard (QSA, QRK, and Tone).
- (d) The report (QSA, QRK and Tone) given by the station heard to the station being worked.

The total points so scored shall be multiplied by the number of Prefix Zones heard, on both 7 and 14 mc.

CQ and Test calls will not count for points

The same station may only be logged once on each band during the Contest.

All amateur frequency bands may be used providing the input to the valve or valves delivering power to the aerial is not in excess of that specified on the competitor's licence, and in no case more than 250 watts, and providing the entrant has permission to operate his station on the band, or bands, in question.

An exchange of reports must be effected before points can be claimed for a contact. Reports shall be based on the QSA, QRK and Tone systems.

Rules for Senior (High Power) Transmitting Contest :

Transmitting Contest :

This section of the Contest will extend from 17.00 G.M.T., Saturday, February 2, to 17.00 G.M.T., Sunday, February 3, and will be continued from 17.00 G.M.T., Saturday, February 16, to 17.00 G.M.T., Sunday, February 17.

One point will be scored for each contact with an Empire station located in a Prefix Zone outside the competitor's zone.

The total points so scored will be multiplied by the number of Prefix Zones worked on both 7 and 14 mc.

Only one contact with a specific station may be made on each band during the Contest.

Rules for Junior (Low Power) Transmitting Contest :

Transmitting Contest :

The rules for this section of the Contest are the same as for the Senior Contest, except for the following:—

The Contest will extend from 17.00 G.M.T., Saturday, February 9, to 17.00 G.M.T., Sunday, February 10, and will be continued from 17.00 G.M.T., Saturday, February 23, to 17.00 G.M.T., Sunday, February 24, 1935.

The input to the valve or valves delivering power to the aerial must not exceed 25 watts.

Prefix Zones

The Prefix Zones for the purpose of these Contests are as follows:—

1. Ascension.
2. Australia (VK2, 3, 4, 5, 7, 8).
3. Australia (VK6).
4. Barbadoes, Leeward and Windward Isles.
5. Bermudas.
6. British Guiana, Trinidad and Tobago.
7. British Honduras.
8. British Isles.

(Continued in 2nd col. page 61)

American Amateur Radio

The Station of W2AND By Henry F. Kroupa.

It is always interesting to know just how the other fellow is going ahead with his experiments. The American station, W2AND, has been consistently heard in this country, and both transmitting and B.R.S. listeners have been anxious to have more definite information as to the hook-up in use.

W2AND has been operating on phone for eight years, generally on the 160-metre band, only having migrated to the 80-metre band quite recently. Various transmitters were used until finally a licence was obtained for me to use 1,000 watts on 75 metres. After a time the kick of operating on this frequency became nil, so thoughts were turned to the 20-metre band and real D.X.

It was attempted to operate the high-power transmitter on the 14 mc. band but of no avail, so it was completely dismantled with the exception of the power supply rack and reconstructed.

Finally, a good circuit was arrived at and is shown in detail in Fig. 1. One of the main changes that I had to make was the use of a Tri-Tet oscillator stage utilising one of the new type 59 tubes. It immediately enabled me to remove one of the buffer doubler stages—as you know the Tri-Tet permits of doubling within the valve itself.

A screened-grid tube is used in the doubler stage. This tube being of the 865 type with a power rating of 7.5 watts.

Flexible Power Amplifier

Finally comes the power amplifier operating on 20-metres. This tube

is of a 50-watt, 203-A type, is of graphite anode construction (similar to the ES75) and is running with 200-250

watts input. Probably readers on your side will raise their hands in alarm at the idea of using 250 watts input on the simple 50-watt type tube. The secret lies in high excitation to the various stages, and is accomplished by using the new method of link coupling now so popular over here. The drive even from the crystal stage into a doubler, gives a grid excitation of 22 milliamperes grid current and 70/90 milliamps. grid current into the final stage with 250 watts input. This variable value is due to poor voltage regulation from the supply but with a lower plate voltage on the oscillator, and output is, of course, correspondingly less.

Coming to the speech amplifier section of the transmitter (see Fig. 2), this is really quite standard, with the exception of a high quality microphone which is only of the single button type. Many British listeners who have heard this station, will probably agree that the quality of it is other than single button.

Actually the speech amplifier is linked up in the following way. First a single stage of type 56 amplification followed by another stage of type 56, driving a pair of 2A3's in push-pull. These 2A3's then feed into a split primary transformer and drive a pair of 203-A's in class-B. The audio output

used only permits of 100 per cent. modulation at all times.

The Antenna Systems

My antenna system comes next and is really a half-wave current fed, middle feed, 20-metre antenna. Each portion from centre to end is exactly 16.5 feet so having a fundamental frequency of 14,150 kilocycles.

A transmission line is in use approximately 100 feet long and is of the untuned type. Matching of this 600-ohm line is done at the transmitter tank coil end.

The transmission line was designed to have a surge impedance of 600 ohms and this was obtained by proper wire gauge and spacing. Actually 12 B.S. gauge wire spaced with 6-inch spreaders are in use. The antenna end is spaced by a 6-inch insulator at the radiator portion and tapped directly on to the plate tank coil.

Tuning is very simple. The centre of the tank coil being grounded, a clip is placed on either side of the tank coil approximately half a turn away. The transmitter is tuned for minimum plate current, when both meters in the antenna circuit should give the same reading. Probably there will be a slight variation owing to difference in feeder lengths so it is necessary to adjust and compensate for the unbalanced reading. This is done by noting which feeder has the higher antenna current and moving the clip towards centre by a very small amount, the feeder with the smaller current being moved away from the centre by a similar amount.

Feeder Balancing

This method of balancing is the same regardless of feeder lengths used, with the exception of placing the clips on the tank coil. If the feeders are used as in this station (approximately half wavelength, although I actually use three half wavelengths on the transmission line) the termination will be of low impedance, so that the clips must be near the ground terminal.

In other than a half-wave antenna, where the clips are to go to the inductance, say, quarter wave, the clips will be widely separated from the ground terminal so that the termination will be a high impedance. You can see quite clearly what is meant by this if

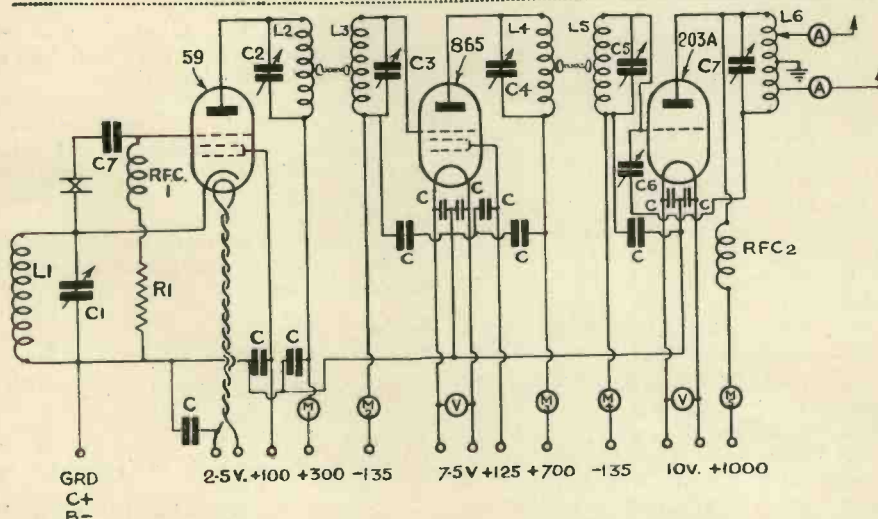

Fig. 1. This is the final arrangement of the radio frequency section of W2AND. Remember that the frequency is 14,150 kilocycles, and the output up to 1 kilowatt.

is of a 50-watt, 203-A type, is of graphite anode construction (similar to the ES75) and is running with 200-250

for modulation is much greater than is needed at the moment so care is exercised to see that the amount of audio

W2AND — Often Heard in this Country

you will refer to the arrangement shown in Fig. 3.

All manner of voltages can be obtained from the power pack. There is a special supply for the crystal giving 300 volts, obtained from a type 83 mercury-vapour tube. A voltage divider supplies the accurate screen voltage. Next comes the 750 volts supply using type 866 tubes as full-wave rectifiers

past few months. This transmitter has actually only been in operation on the 14-megacycle band for a little over a month, but already contacts have been made with British, Mexican, West Indian, Portuguese, Cuban and all American and Canadian districts. These are actual contacts not counting the number of reception reports from all over the world.

15. Hong Kong.
16. India (North of Cancer).
17. Iraq.
18. Jamaica, Cayman, Bahamas, Turks and Cairos Islands.
19. Kenya, Uganda, Tanganyika and Zanzibar.
20. Malta.
21. Mauritius.
22. Newfoundland.
23. New Zealand and Chatham Islands.
24. Nigeria, Sierra Leone and Gold Coast.
25. Papua and British New Guinea.
26. Palestine and Transjordan.
27. Rhodesia.
28. Singapore, Borneo and Malaya.
29. St. Helena.
30. Union of South Africa.

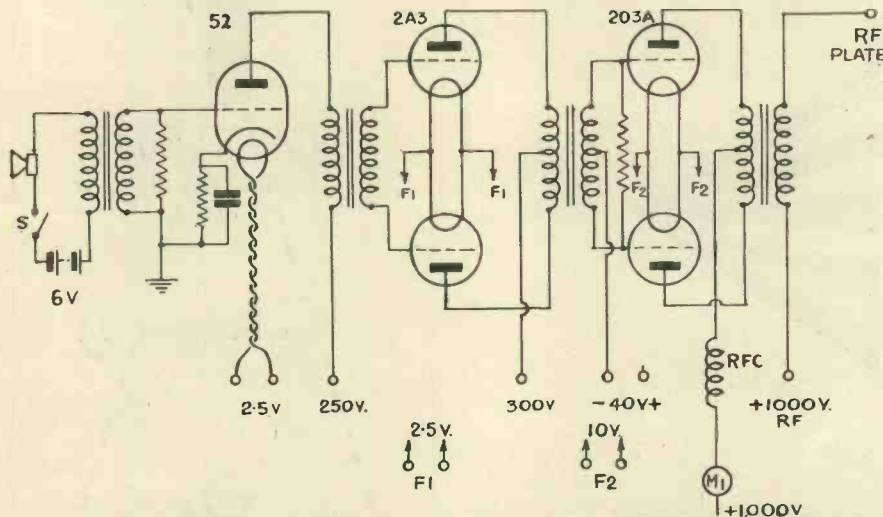

Fig. 2. Class B modulators are used by Henry Kroupa and English listeners can probably testify that the quality from W2AND is very F.B.

Mirror Drum Illumination.

A sub-standard cinematograph projector will give brilliant illumination on a screen 4 ft. by 3 ft. with a 250-watt lamp. It is doubtful whether a similar picture could be obtained with a mirror drum using the same illumination even without the interposition of a Kerr cell.

With the cine projection the light flux is uniformly distributed over the screen. With a mirror drum the light is concentrated in one spot and this spot is caused to scan the area.

If we assume a 30-line band picture the light will be concentrated in an area $\frac{1}{30 \times 70}$ of the whole, i.e., it will be 2,100 times as bright. The question is whether such a bright

again with a voltage divider for screen potential.

High tension for the final radio tube is variable between 1,000 and 4,400 volts, obtained by means of taps on both primary and secondary of the transformer in conjunction with a pair of 872 rectifiers.

The class B modulators have a separ-

The receiving equipment is a Hammurund Crystal Pro having two stages of high-frequency. I base a lot of my contacts on the fact that I use a 20-metre doublet antenna for receiving which couples up to the Crystal Pro by a pair of twisted feeders. The overall length is 33 feet and it runs north to south.

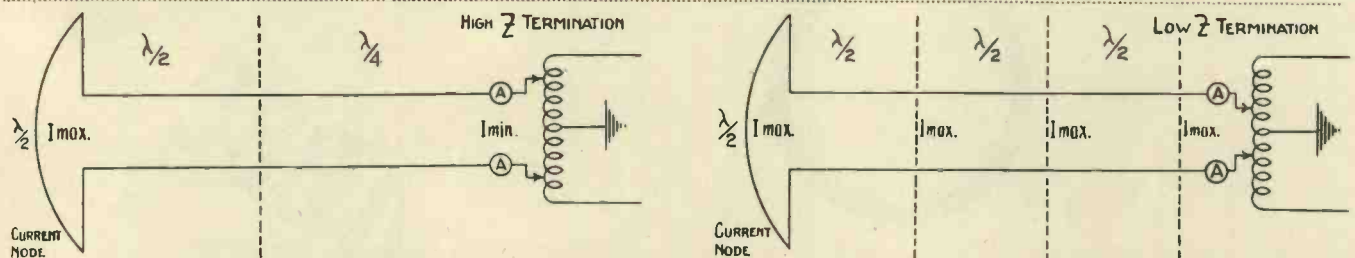

Fig. 3. These circuits give you some idea of the transmission lines having high and low impedance termination. Full details are given in this article.

ate supply of 1,000 volts again using a pair of 866's. Tappings on the primary also enable me to vary the supply between 900 and 1,400 volts if required. Finally comes the supply for the speech amplifier, consisting of 300 volts from a type 83 mercury vapour tube.

That is about all for the actual transmitter and the efficiency of this circuit can be gauged from results during the

"The B.E.R.U. Contests."

(Continued from page 59).

9. Burma and Andaman Islands.
10. Canada (VE1, 2 and 3).
11. Canada (VE4).
12. Canada (VE5).
13. Ceylon and India (S. of Cancer).
14. Egypt and Sudan.

light spot acting for 1/2,100 of the full time produces the same effect on the eye as a less brilliant illumination acting continuously.

The physiology of the eye would suggest that the effects are not by any means the same and practical experience seems to bear this out.—
J.H.R.

THE B.B.C. TEST TRANSMISSIONS

Recently the B.B.C. transmitted a series of test diagrams which we have thought it desirable to reproduce. Although they may not be transmitted again for some considerable time it will be found that useful comparisons can be made with the caption cards which are used in every programme and enable a useful test of results to be made.

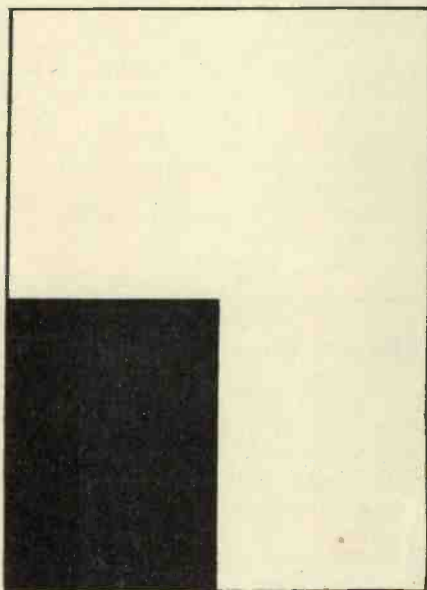

Low-frequency Test Card

Amplitude attenuation of lower frequencies in 12.5 v. to 100 v. range will reproduce this pattern with a falling off of intensity of black to white, while phase distortion usually produces, on radio reception, a brilliant white quarter above the black quarter, with a decided greying of the left-hand quarter, compared with the quarter below it. Generally both faults occur together.

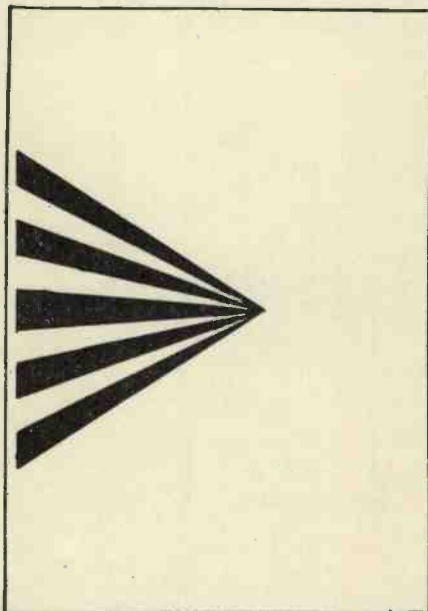

H. F. Test Card

This always appears with a greyish-black point as far as the third or fourth line from the point, that is to say on the fourth or fifth line from the point the black and white converging line should be clearly seen. If the greyish-black occupies space to the seventh line your pictures will be fuzzy or have, in photographic language, an out-of-focus effect.

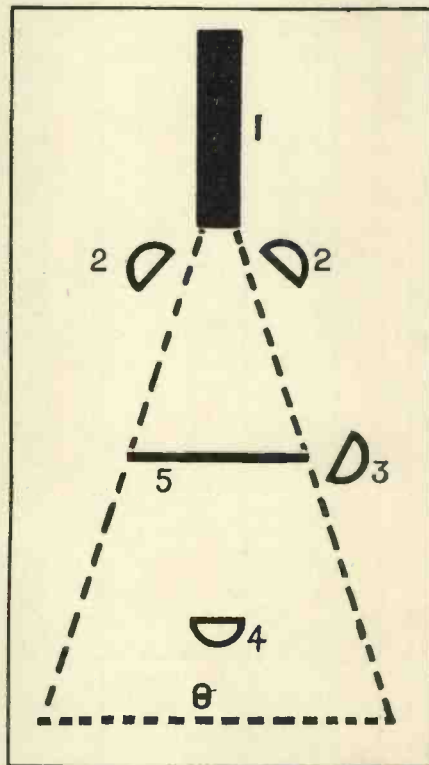
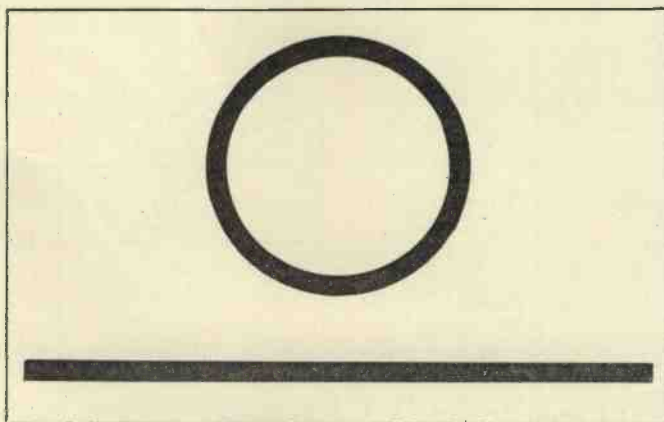

Photo-cell positions

Diagram showing photo-cell placings in studio. 1, projector; 2, two front photo-cells in parallel; 3, side cell; 4, back cell; 5, artist's stand on this line; 6, six white back-ground.

Signal is usually taken from all three groups of cells, if only from front ones it produces white face on black background, from side cell brilliant side lighting, and back cell, a silhouette.



Picture Ratio Test

Circle and straight line used to test accuracy of picture ratio and angular displacement. If the circle appears as an eclipse the 7 : 3 picture ratio is out. Should the greatest axis of the eclipse be vertical, the height is too great compared with the width, or vice versa if the greatest axis is horizontal.

If the straight line has a uniform slope it shows progressive angular displacement. If

the line appears jagged it indicates irregular angular displacement.

It should be noted that though the circle is of uniform thickness it is reproduced with the top and bottom apparently thinner than the sides. This is due to the resolving power of the system being greater in the spot traverse direction than that of line traverse.

The B.B.C. television eye is transmitted frequently.



THE RELATIVE EFFICIENCIES OF MIRROR-DRUM AND DISC RECEIVERS

This article, by Robert Desmond, explains the apparent discrepancies between the theoretical performances of mirror-drum and disc receivers, and gives much valuable data on the relative optical efficiencies of each type.

IN the September, 1934, issue a description was published of a mirror-drum visor which for its light source used a mercury recording tube and gave a picture of 7 in. high. Next month a description of a projected image disc receiver was given using a T.I. neon-mercury lamp as light source and giving an image 4 ins. high.

A reader pointed out that the difference in area was three times (it is actually 3.25) that the usable amount of light for the disc machine at any instant could be

$$\text{only } \frac{1}{30} \times \frac{1}{30 \times \frac{7}{3}}, \text{ which he approximated to } .05 \text{ per cent.},$$

and which is on the generous side.

With regard to the mirror-drum receiver he assumes that the light efficiency is at least 50 per cent., and with 1,000 times more light he is at a loss to understand why images are obtained only three times the area, instead of 1,000 times. In both cases he pointed out that the losses in lenses and mirrors has been ignored,

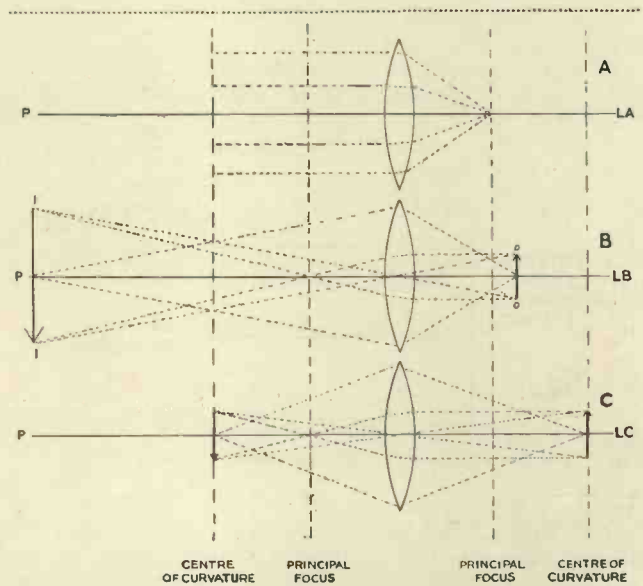

Fig. 1. Theoretical diagram showing the principle of a simple lens.

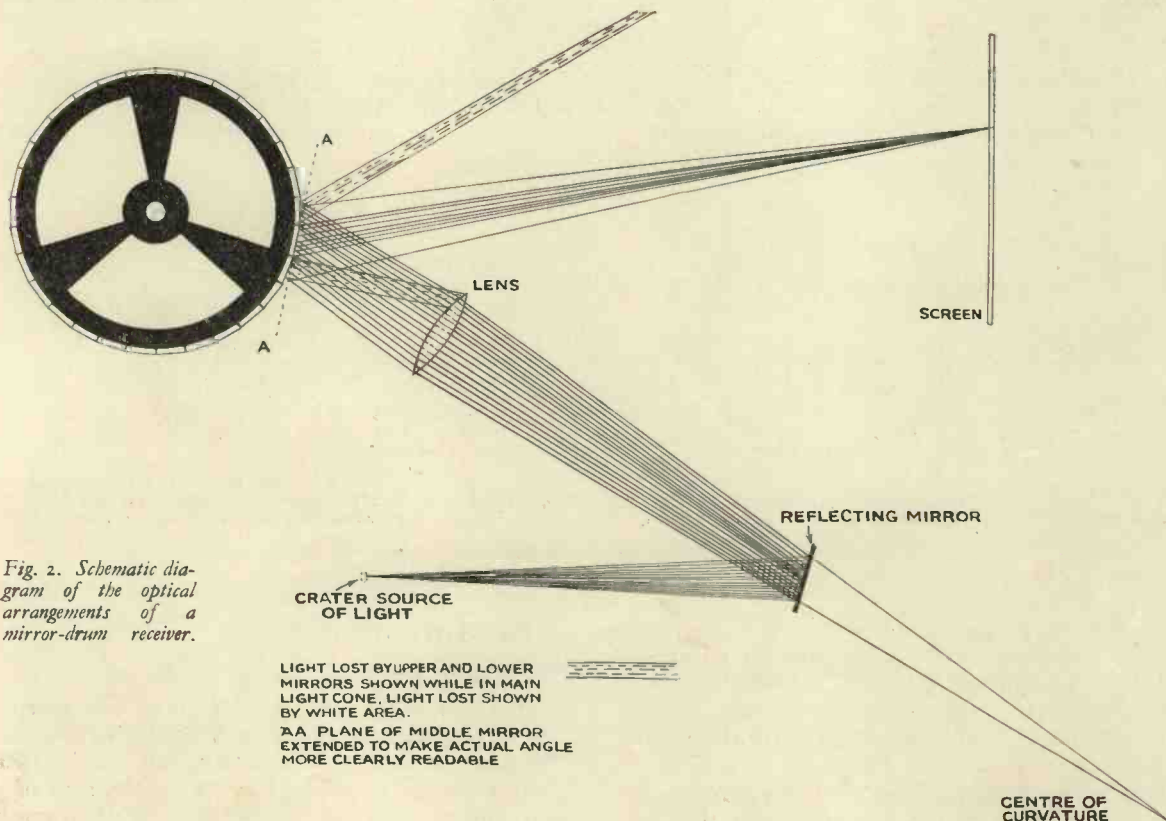

Fig. 2. Schematic diagram of the optical arrangements of a mirror-drum receiver.

LIGHT LOST BY UPPER AND LOWER MIRRORS SHOWN WHILE IN MAIN LIGHT CONE, LIGHT LOST SHOWN BY WHITE AREA.
A-A PLANE OF MIDDLE MIRROR EXTENDED TO MAKE ACTUAL ANGLE MORE CLEARLY READABLE

MIRROR-DRUM OPTICAL THEORY

also that the amount of usable light is probably greater with the T.I. lamp than the recording tube, but suggests surely not as much as $\frac{1,000}{3}$ times as great.

Two things, of course, we do not know; that is how the brilliance of the two screens compared and also the relative intensity of the two light sources, which, of course, must be similar or their difference known for true comparison.

A superficial consideration of the disc and mirror-drum systems definitely gives one the idea that the

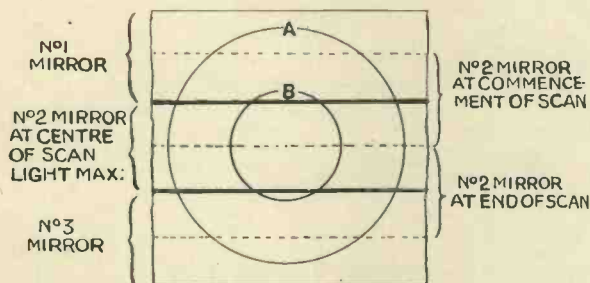

Fig. 3. Diagram explaining how light losses take place with the mirror-drum.

mirror drum must be at least a thousand times more efficient over its disc counterpart, but actually this is not the case. Let us look into the matter of how they really do compare.

Lenses and Images

First of all let us refresh our memories on the image-forming properties of a simple convex lens. In Fig. 1 we have three simple lenses of similar characteristics. Simple lenses have two important points on either side

rays emerge parallel on the other side of the lens (A, Fig. 1). If the same source of light is put between the principal focus and centre of curvature, the rays of light will converge at some point further than the centre of curvature on the other side (B, Fig. 1); in this drawing an object is also shown, OO, of which a real and enlarged image is produced II; also note the

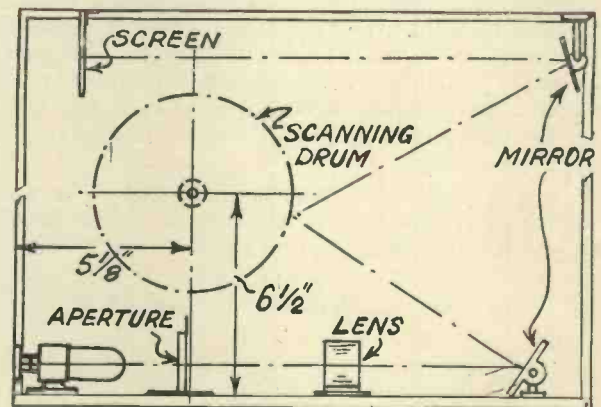

Fig. 3a. Layout of a typical mirror-drum receiver.

cones of light a point source of light would produce.

C, Fig. 1, is similar to B except that the object and light source are at the centre of curvature. In this case note the image and object are the same size; also the angle of the light cones. In every case the object or light source could be put on the left-hand side, reversing images and objects. Before leaving Fig. 1, note carefully that in the case of a light source the amount of light collected for a given lens diameter is greatest when the light is at the principal focus, or for a given diameter the shorter the focus the more light collected.

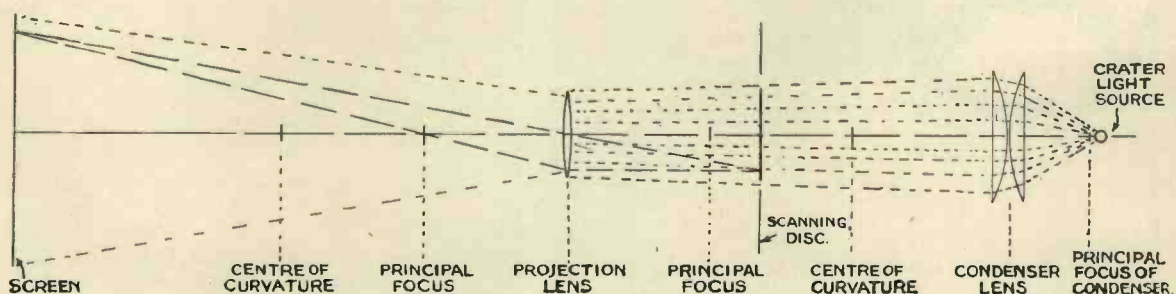

Fig. 4. Diagrammatic layout of a disc projection receiver.

of them: the principal focus, that point where all parallel rays are refracted to, and centre of curvature which is the centre of the sphere of which the lens is part. Both these points lie on the principal axis, on which also lies the optical centre, a point in the middle of the lens.

If a point source of light (the more it approaches a point the better) is put at the principal focus the light

The Mirror-drum in Theory

We will start with the design of a mirror-drum receiver of which Fig. 2 is a schematic diagram, the original of which was drawn half size. The screen was taken as 8 ins. high, which gives a width of 3.43 ins., an average size. The scanning spot will measure

LIGHT LOSSES IN MIRROR-DRUM RECEIVERS

.114 in. across, which will probably be very little smaller or larger than the width of an available crater type of glow-lamp and as it is the image of this which is projected on the screen, it will have to be placed in close proximity to the centre of curvature of the projection lens. Another distance which is fixed for us is that of the distance of the screen from the mirror-drum.

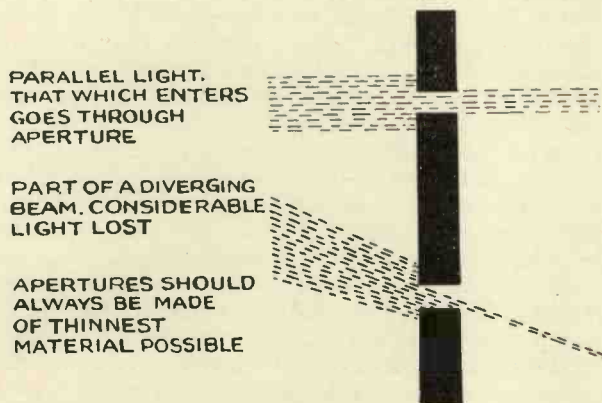

Fig. 5. Diagram showing loss of light if a thick disc is used.

This is due to the fact that the angle of reflection between adjacent mirrors is 24 degrees, therefore the operating mirrors are always 2.22 times the height of the screen away from it. More light is reflected from an ordinary mirror, the smaller the angle between the incident ray and the reflected one, so all angles must be as acute as possible.

The next thing to consider is the lens. Obviously its focal length will depend principally on the size of the screen (that is assuming a light source of about

where at least .6 and often as much as .9, of the incident light on the mirror-drum is lost, as the cone of light should cover at least 2.5 mirrors if the screen is to be evenly illuminated. With the aid of Fig. 3 an attempt will be made to explain this rather serious effect which robs a mirror-drum of so much of its light.

The circle A represents the beam of light falling on three mirrors. No. 2 is the mirror from which the reflection is producing the spot on the screen. In the position of the black heavy lines the light reflected will be maximum. The light falling on mirrors 1 and 2 is lost (this is also shown in Fig. 2). Another matter Fig. 3 illustrates is that when mirror 2 is moved 6 degrees (half its width) a reduction of incident light takes place, which results in a slight falling off of the brilliance of the screen at top and bottom.

Supposing the light in circle A was concentrated into circle B, the intensity of the spot would be considerable greater, but there would be nearly 50 per cent. falling-off of brilliancy at the top and bottom of the screen.

Turning to the mirrors on the drum, it will appear that the optimum length is 2.5 times their width, and, for preference, without any fixing devices being in the working area; also the glass should be as thin as possible, which, of course, is true of all mirrors.

The fixed mirror is not really necessary for the optical success of Fig. 2, though in practice it would make a receiver so designed more compact; it would be more efficient however if the light source were at the centre of curvature. We have now considered all the individual optical parts which go to make up the receiver except the screen. The writer, after trying many substances, considers finely ground photographic focusing ground glass the best. Anything more transparent, while giving a brighter picture, has too transparent a tone and also a rather too directive viewing angle.

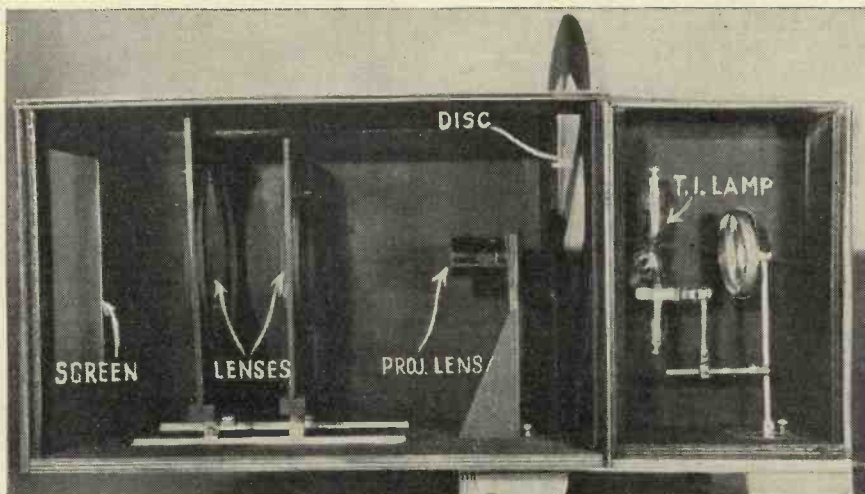

The first disc projection receiver described in the November (1934) issue of this journal.

.1 in. across, which will be assumed throughout this article), while the larger the diameter the more light it will collect. In Fig. 2 a lens of 12 in. focal length was chosen, as the writer's practical experience judged it to be about optimum value, with a diameter of 3 ins.

We now come to a very important point and one

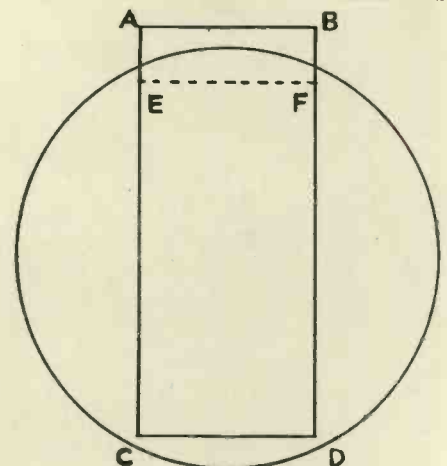

Fig. 6. Loss of light at disc.

ABDC the 7x3 picture ratio of which ABFE is taken up by synchronising area, therefore we need only illuminate area EFOC and have somewhat higher efficiency.

Light Losses

Now let us see how much light we have lost. We will assume that the light source gives an evenly illuminated cone of light over an angle of 100 degrees. Of

this only some 6 degrees is collected, so only 6 per cent. is left; of this about 15 per cent. will be lost by the fixed mirror, leaving us 5.1 per cent. of the original available light.

The lens will absorb some light, and this will vary with different lenses, but 15 per cent. again is a fair figure. At the drum at least some 60 per cent. is lost for reasons already given, while of that which is reflected, another 15 per cent. is lost, so finally 1.475 per cent. of the light radiated from the lamp is projected on to the screen, where again loss occurs. Of course, a screen produces an equal loss whether the spot is projected from a mirror or disc.

In the mirror-drum receiver described in the September issue there are two further causes of loss of light. First, a second reflecting mirror is used to obtain compactness, and, secondly, the light source is not itself projected, but an adjustable aperture is illuminated by it and as it is shown in the drawing, Fig. 3, A, at quite some distance from the light source, the angle of collection is extremely small.

The Disc Receiver

Now let us turn to Fig. 4, the diagrammatic layout of a disc-projection receiver. Using the same lamp we get a much better angle of collection by the condenser as here we put the light source just outside the principal focus so as to produce a slightly converging beam. It should be noted that a certain amount

of light is lost when passing through an aperture (see Fig. 5). This converging beam is projected on to the disc and owing to the rectangular picture shape more light is lost, as will be clear from Fig. 6.

The projecting lens should be of suitable diameter to collect all the converging beams, as shown in Fig. 4. Its F/number, that is to say the relation of its diameter to focal length does not matter.

Again, let us examine losses. Using the same lamp the condenser collects 65 per cent. though in itself probably loses 20 per cent. as the usual cheaper pattern of condensing lens is made of thick greenish glass. At the disc first there is the loss shown by Fig. 6, which is some 56 per cent. That shown in Fig. 5 we can ignore unless the disc is made of abnormally thick material. We then, of course, only use .0476 per cent. of what is left on a 30-line picture of which the projection lens loss is another 15 per cent. So we are left with only .0093 per cent. to project on to the screen. So in these two instances the intensity of the mirror-drum spot is 159 times that of the disc using the same source of light. Also, of course, as the screens are as 1 to 4, the efficiency of the mirror-drum visor is proportionally better. It should be noted that most mirror-drums do not have the mirrors 2.5 times their width long and it would be probably truer to say 90 per cent. and not 60 per cent. is lost by this fact, which reduces the mirror visor to only .368 per cent. light efficiency, other losses being as before.

It should clearly be understood that the mirror and projected disc visors could both be made more efficient than the two theoretical layouts examined.

The Gillavision Cathode-ray Receiver.

A complete cathode-ray vision receiver has been placed on the market by Gillavision Television, 23 Chil-



The Gillavision cathode-ray receiver is entirely self-contained.

worth Street, London, W.2. It is designed to receive the B.B.C. transmissions on 261 metres with 30-line definition (the set is easily converted to any other definition and wavelength). The receiver is designed to operate on 200/240 A.C. with indoor aerial and earth, the whole being housed in an attractive oak or mahogany case, as shown by the photograph. Operation is simply by the turning of the four knobs on the front of the cabinet. The pictures, it is claimed, invariably remain in synchronism and once having been adjusted the receiver requires no further attention. The retail price is 55 guineas. Sound is not obtainable on this set and an additional receiver must be used for this. The size of the cabinet is approximately 50 ins. by 16 ins. and the diameter of the screen 5 ins.

Talking over a Light Beam at 100 Miles an Hour.

Following the article on the talking light beam which appeared in the January issue of TELEVISION, it was interesting to read of an American experiment using this device, which

was described in the *Radio News* for February, under the above title.

Engineers of the American General Electric Co. equipped the new Union Pacific six-car streamlined passenger train with a modulated light-beam searchlight which consisted of a concave mirror and a powerful modulated light-source. Details of the light-source are not given, but from the statement that the apparatus emitted a beam of "orange-red" light it may be assumed that it was either a crater neon or sodium vapour lamp.

Erected on the platform at Schenectady was a tripod carrying another concave mirror with a photocell at its focus and connected to this was a public-address amplifier with loud-speakers. As the train entered the station the modulated light-beam from the engine cab was trained on this receiving apparatus and by means of a microphone the passengers were able to call greetings to the crowd gathered on the platform.

This experiment suggests the possibility of using this device in fog when by means of an infra-red modulated beam it would be possible for signalmen to impart instructions to train drivers when the ordinary signals are rendered invisible.

THE FIRST KERR CELL

Every television experimenter has used the name of Kerr many times, but few are acquainted with his work on electricity and optics. In this article G. Parr describes the discovery which made his name famous. The photographs which illustrate the text are reproduced for the first time by permission of the authorities of Glasgow University.

IT was during an argument on the original liquid used in the Kerr cell that the question arose "Who was Kerr?" and of the four persons present only two knew that he was any more than the giver of a name to a certain piece of apparatus which

was formed in a disused cellar in the basement, and it was here that Kerr started his experiments which were to have such far-reaching results.

In 1857 he was appointed to the post of Lecturer in mathematics at the Free Church Training College for

Teachers, a position which seems inadequate for his talents, since he had graduated with the highest honours at the university and had won several prizes for his work. At the Training College, however, he proceeded to set up a private laboratory financed largely from his own pocket, and it was here that the majority of his spare time was spent.

on the relation between Magnetism and Light. Faraday had already discovered in 1845 the effect of a strong magnetic field on polarised light and it occurred to Kerr to investigate whether a similar effect existed for the electric field. The first paper published by him, referred to above, is confined to the effect of the electric field on solid bodies through which polarised light is passed, and the first experiment was made on the block of glass, shown in the photograph of Fig. 1.

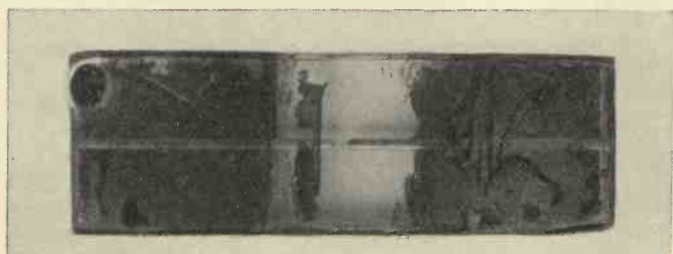

Fig. 1. Block of glass used by Kerr in his first experiments on electro-optics.

is so widely used in television. On looking up the facts in that home of reference, the Patent Office, such an interesting amount of detail was obtained that it was thought that the readers of TELEVISION would like to know something about the quiet unassuming physicist who made such an invaluable contribution to the science.

Dr. John Kerr (his degree was conferred on him by the University of Glasgow in honour of his work) was born in Ardrossan on December 17, 1824, and entered the University as a student in 1841. About this time Sir William Thomson, afterwards Lord Kelvin, took up his work in the University and Kerr started his research into electricity and magnetism

Teachers, a position which seems inadequate for his talents, since he had graduated with the highest honours at the university and had won several prizes for his work. At the Train-

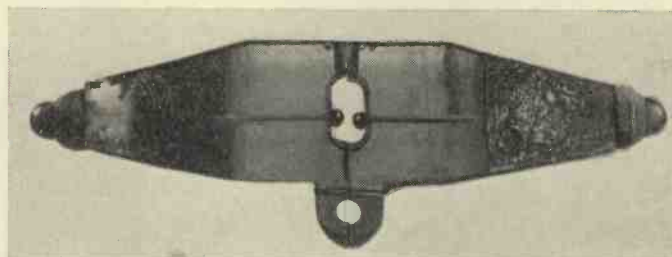

Fig. 2. One of the first liquid cells used in 1879.

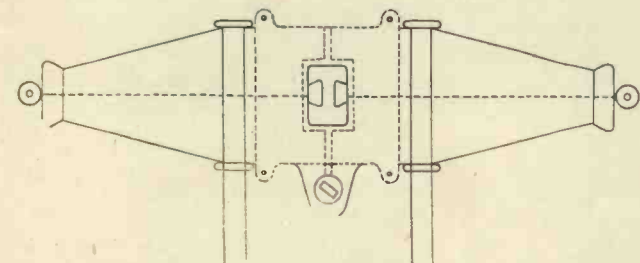

Fig. 3. Diagram of early Kerr cell taken from the Philosophical Magazine of 1877. The dotted lines indicate the wood clamps not shown in the photograph of Fig. 2.

under Kelvin's guidance. One of the first physics laboratories in the country was instituted at Glasgow Univer-

preface that the train of thought which led to the research was prompted by the memoirs of Faraday

ing College, however, he proceeded to set up a private laboratory financed largely from his own pocket, and it was here that the majority of his spare time was spent.

In 1875 he published the first results of his researches in Electro-Optics in the "Philosophical Magazine" under the title of "A New Relation between Electricity and Light" or "Dielectricity Media Bi-refrangent" acknowledging in his

lac (or as he terms it, "lac"). As a source of high potential he used the most powerful apparatus available at that time, the Ruhmkorff induction coil, which gave a spark of 25 cms.

The glass slab was mounted between two Nicol prisms, and a source of light placed in front of the first. The analyser was then turned to the point of extinction of the light passing through the combination and the coil was switched on. The light then reappeared, and as he states "could not be extinguished by any rotation of the analyser."

The experiment sounds simple in the telling, but we have only to read his careful account of it to realise the amount of time and care which characterised the whole of his research work. The drilling of two holes 1/10th of an inch diameter and

2-3 ins. long down the centre of a glass block is a task which would worry a number of present-day experimenters, even with the improved means at their disposal which we now have! In the original block, these holes are drilled beautifully with neatly rounded ends and are in perfect alignment, as will be seen from the photograph. Dr. Kerr and his

The First Liquid Cell

Later in the same year he published the results of his work on liquids in the electric field, the experiments on which he had foreshadowed in the former communication.

The cell used was one which un-

mahogany "planks" to use Dr. Kerr's own term. The "planks" were held together by four clamping screws fastened with "bat's-tail" nuts. Unfortunately, after Kerr's death the experimental apparatus in his laboratory was scattered, and when the Glasgow University acquired it the mahogany planks and the bat's-tail nuts were missing. The cell, too, was broken, as can be seen from the photograph. Doubtless some of the damage was caused in Kerr's time, as there has been an attempt to rivet the two halves together by the usual copper wires similar to those used in china riveting. The holes drilled for these rivets can be seen at the top of the cell.

The liquid used in the first experiments was carbon disulphide, and a variety of others was also tried, including xylol, terebene, and, lastly, nitrobenzol. A note is given in the paper to the effect that sulphur chloride, carbon tetrachloride and phosphorus trichloride were tried but without effect, as they acted as conductors.

The arrangement of the apparatus is shown in Fig. 4. An interesting feature is the provision of two slabs of glass to act as compensators for

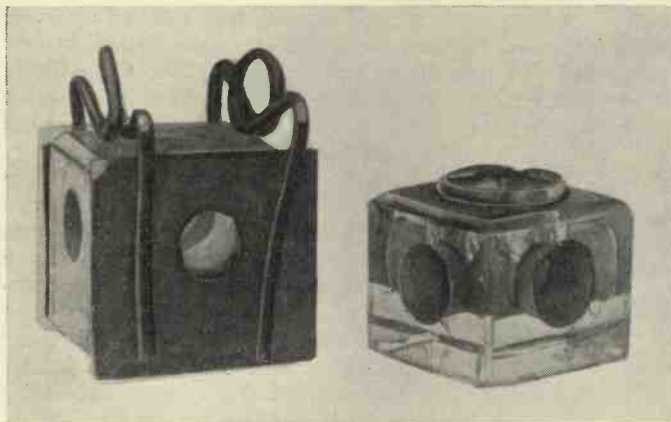

Fig. 6. Two more liquid cells made from a glass cube (left) and an inkpot (right).

assistants seem to have been experts at drilling holes in glass, as the later photographs show.

But to return to the researches. In 1877, he turned his attention again to the relation between magnetism and light, and published the following statement, which has become known as the "Kerr Effect":—"When

fortunately was not available for photographing at the time the others were taken, but the first cousin to it is shown in Fig. 2, and since this cell is described in detail in the "Philosophical Magazine" for 1879 it may fairly be considered as the original of the Kerr cells.

A similar block of glass to the one first shown was bored from end to end and the centre portion scooped out to form a cell for the liquid. The construction of the whole cell is shown in Fig. 3, which is copied from the illustration in the "Philosophical Magazine." The central aperture was filled through the hole shown in the top of the plate, and at the bottom was a similar hole fitted with a tap and ground joint. The cell was closed on each face by two sheets of plate glass about 1/16-in. thick held on to the block by two small

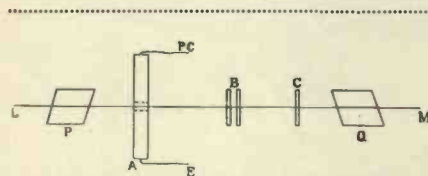

Fig. 4. Kerr's diagram to illustrate his experiments. The liquid cell is shown at A. The remaining letters are explained in the text.

plane-polarised light is reflected regularly from either pole of an electromagnet of iron, the plane of polarisation is turned through a sensible angle in a direction contrary to the normal direction of the magnetising current, so that a true South pole of polished iron acting as a reflector turns the plane of polarisation right-handedly."

This was an advance on the work done by Faraday, and, as Dr. Andrew Gray said later, "Truly Kerr's name deserves to be bracketed with Faraday's in this connection, and he would have desired no higher an honour."

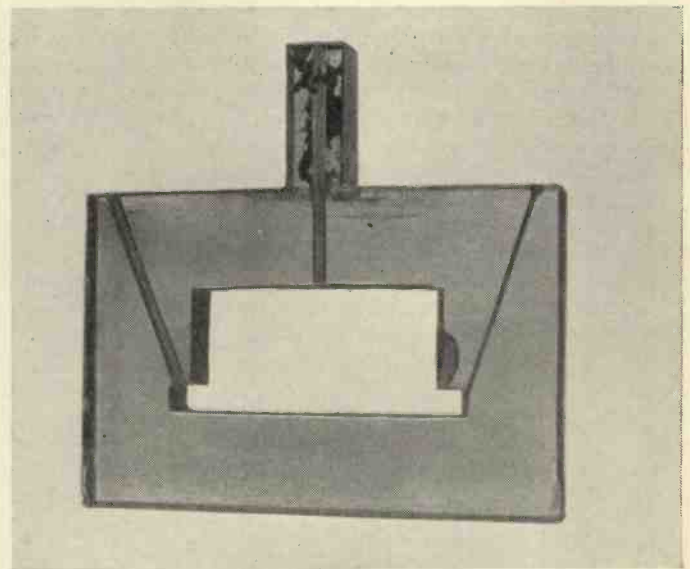

Fig. 5. Solid slab of glass drilled and cut away to form a liquid cell.

the slight depolarising action which the cell itself had on the light beam. These are shown at B and C in the diagram. L is the light source, described by Kerr as being a "paraffin flame, flat, and very brilliant," P the polariser and Q the analyser. In the experiment he was greatly troubled

(Continued at foot of next page.)

G2KT Tests the 1-V-1 Band-Spread Receiver

G2KT the well-known amateur transmitter, who has been actively engaged on transmitting problems since 1911, has tested this receiver under normal working conditions. Read how he found it when used in conjunction with his transmitter at Rayleigh.

I HAD the opportunity of testing the new Kenneth Jowers Band-Spread receiver over the week-end in conjunction with my transmitter at Rayleigh. It is very simple in operation, a very desirable feature when searching for weak DX stations, while its ability to hold a station on the very lowest wave-band is remarkable.

Reaction is very smooth so that the last ounce can be got out of it without trouble. Band-spreading is very useful, particularly when listening on the crowded amateur bands. Actually, quite a considerable amount of movement can be made without the station being lost.

The conditions during the test were none too good for long-distance reception, but in spite of this I was able to log several of the American 20-metre phone stations on the loud-speaker.

On the 40-metre band Scottish phone stations were coming in at good strength. I also heard several VK's, W's, VE's, CT's, SM's, while the usual Continentals were at a strength uncomfortably loud for headphones.

This is J. E. Nickless, G2KT, with his crystal-gate super-bet. Single-signal supers are fast coming into popularity.



The 80-metre band also gave equally good results and G6CW, G5SY and PAOAI were amongst the many stations heard.

Good results were obtained on the top band (160 metres) and phone signals from the following stations were received on the loud-speaker, G6KV, G2DD, G2OV, G5UK, G5QM, G2LZ, etc.

As regards the running of the re-

ceiver I did try using a high-tension eliminator housed inside the receiver case. The hum level was low. With a loud-speaker it was inaudible while with headphones it did not interfere with reception in the least.

I would like to say that in my opinion this receiver fulfils a long-felt want and its ease of control and entire lack of hand-capacity effects are particularly noteworthy.

Instructions for building the 1-V-1 Band-Spread are on page 71.

"The First Kerr Cell"

(Continued from preceding page.)

with dust particles which settled on the liquid under the action of the electrostatic field, and great care was taken to keep the apparatus "specklessly clean." In the case of benzol, the discharge through the liquid itself converted some of it into carbon particles.

The research on liquid dielectrics begun in 1879 was carried on for some time and a further report was sent to the "Philosophical Magazine" in 1880. An example of the apparatus used in his later research is shown in the photograph of Fig. 5, which shows a slab of glass cut from the solid with the centre scooped out. The extension piece at the top has a hole bored through the centre and there are two more holes drilled diagonally down the sides. This slab was one of a number, all drilled with

the same beautiful precision and neatness.

The photograph of Fig. 6 is unique in showing to what use the domestic inkpot can be put! It has been drilled in two directions with larger holes, and must have been an ideal cell for the study of liquids. A similar cell, to the left of the photograph, is made from a polished cube of glass with bevelled edges, the ends sealed with slips of rubber sheet, held in place with the curious brass clips shown.

No reference to these cells has been found, so presumably they belong to a later period in the researches.

In 1890, Kerr was elected to the fellowship of the Royal Society, the supreme honour in the physics world, and he received the Royal Medal for these researches in 1898. In 1901 he retired, and lived quietly until his death in 1907. Speaking of him at the Royal Society in 1907, Dr. Andrew Gray said "The almost fever-

ish haste of many may well feel rebuked when it is remembered that he was 51 before he published his first paper, and every detail of his work stood the scrutiny of the best investigators of the time."

In the account of his first experiments in the "Philosophical Magazine," Dr. Kerr said:

"I cannot conclude without expressing the hope amounting almost to belief that the plate cell charged with carbon disulphide will develop from the present rude beginning into a valuable physical instrument." How pleased and interested he would be if he could see the use to which we have put his wonderful discovery!

The writer's thanks are due to the authorities of Glasgow University for permission to publish the photographs in this article, and in particular to Dr. R. C. Gray, of the Physics Department, for his enthusiasm and help in their preparation.

AN INGENUOUS SPEED-CONTROL SYSTEM

A VERY clever speed-control device has been patented by A. J. Ashdown, which doubtless could find a useful application in television. The device makes use of a tuning fork or tuned reed which does not require any excitation other than that of the power which it controls. The remarkable simplicity of the idea is not its least interesting feature.

Speed regulation by tuning-forks has been known for some years in a form in which the fork members are excited by electro-magnets, on the arms of which are fitted braking pieces, or which operate contacts to a phonic motor. As remarked above, however, the salient feature of the Ashdown system of controlling speeds by tuning-forks is that the mechanism, or small motor, itself energises the fork.

In an experimental model shown by the photograph a small motor has,

held firmly in a wooden (or rubber) block. This will be clear from the diagram.

The Ashdown tuning fork speed control can be seen at the top right-hand side of the vertical case. The numbered dials on the right of the picture are for speed checking purposes.

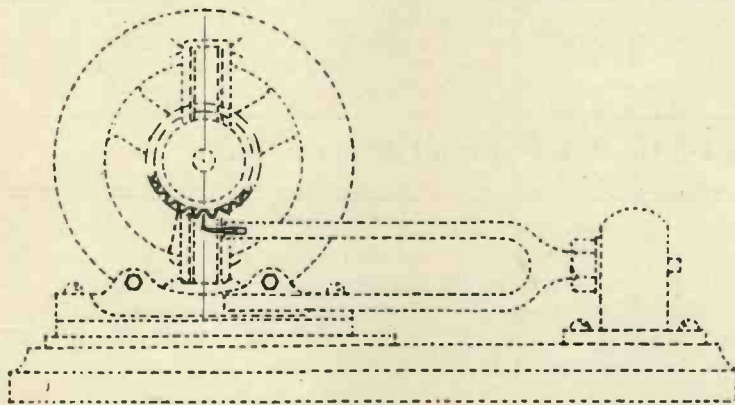
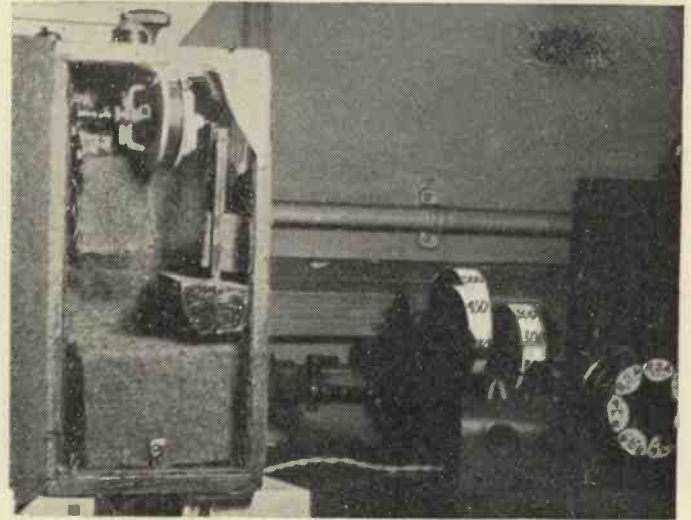

fitted to its shaft, a wheel with standard involute teeth which engage with a thin tongue of tempered steel, called a "detent," fitted to one of the fork arms, the fork itself being

The detent is set so that it only just touches the tips of the teeth. As soon as the motor is switched on, it runs up rapidly to the speed at which the teeth of the wheel are moving at

a rate of speed corresponding with the frequency of the fork, at which instant the arm starts oscillating, and by its amplitude, carries the detent deeply into the toothed spaces, thus providing a perfect chronometric escapement at speeds up to as high as 800 beats per second.

The speed of the toothed wheel is naturally in direct proportion to the

frequency of the fork used, and inverse to the number of teeth in the escapement wheel.

In the model shown by the photograph, the small motor runs up to speed in about one second, and remains constant within a degree of accuracy (measured by a meter index attached to the shaft) of $1\frac{1}{2}$ in 10,000. In another, the mechanism, a heavy clockwork motor capable of driving the main spindle at over 1,000 r.p.m., was actually controlled to 1 per minute within an accuracy claimed to be as high as 0.75 sec. in 9 hours running; i.e., 1 part in over 40,000.

One peculiar feature is that the detent registers scarcely any wear after lengthy running, and it is said that (probably on account of the small mass of the fork) the timing is not sensibly affected by normal changes of temperature.

This is a schematic diagram of the Ashdown speed control which no doubt would lend itself admirably for the control of mechanical scanning devices.

Lee De Forest and Television.

Dr. Lee De Forest, who was so largely responsible for the development of the valve, during the course of a recent interview, said: "Improvements in television will not come by way of the cathode-ray tube. They will come by way of mechanical reproduction. I know, I travelled all over Europe last year and

saw all their equipment, but I am still convinced that the cathode-ray tube does not hold the solution to the problem, that it lies in mechanical reproduction."

In view of the above statement, it is interesting to review De Forest's views, syndicated by the Canadian Press, July 4, 1934. He was interviewed in Montreal. "There has been a lot of talk that television is 5 years away," said De Forest. "It is nothing of the sort. It has been an engineering possibility for some time and now I think it is commercially possible."

READ
TELEVISION
REGULARLY

The 1 - V - 1 Band-Spread Receiver

This set was specially designed by Kenneth Jowers, for the B.E.R.U. Contest, of which full details are given on another page of this issue. It is eminently suitable for amateur band reception.

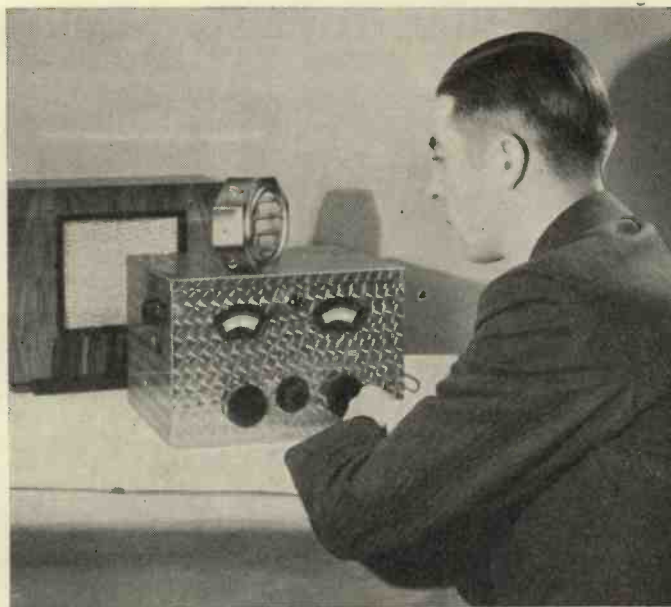

As the receiver is totally enclosed there is little likelihood of its picking up local interference. Direct pick-up from the local station is also reduced.

THIS is neither the time nor the place to discuss the merits or demerits of the multi-valve and simple short-wave receivers. During the past year my correspondence has been very much increased owing to this controversial topic, but so far I have not really come to a definite conclusion as to which is the best receiver on the short waves.

All I can say is that after a great number of years of short-wave work I have used a multi-valve receiver for general listening and a simple two or three valver for real DX work.

By general listening I mean reception of American phone stations, Buenos

Aires and perhaps the Europeans such as Moscow, Rome and so on. Normally I have a twelve-valve receiver always in use and with it I can, of course, pick up a large number of phone stations at full loud speaker strength. Stations such as W3XAL, W8XK, can be received at almost 100 per cent. consistency, and for about nine months of the year I can rely upon American reception from lunch-time onwards.

But even so, when it comes down to real DX work, such as Australian phone stations, or some of the 10-watt 20-metre phones the other side of the world, I do find that the background noise level of the large receiver is much

too great. Consequently for the last two or three years, I have been using a three-valver with a pair of headphones. I am not trying to tell you that the three-valver will do more than my big set, but the point is that with a pair of headphones and on a weak signal, I cannot turn up the big set owing to the strong background noise level. With the little fellow, providing the aerial is correctly coupled to the receiver and tuning carefully done with reaction at maximum, I can usually bring a signal up to R5 without much trouble.

During the winter months, this low noise level with the small set is a distinct advantage. I have been able to hear 20-metre phone stations, not at great strength, but quite easily readable, whereas my larger receiver was infinitely more noisy, and actually did not give me any more, with regard to DX stations.

The Best Type of Set

Another point in favour of a small set as against a super is that you don't get second channel readings. One of the disadvantages of a super-het is second-channel interference, that is stations always come in at two positions of the tuning dial and usually within about ten degrees of one another.

Of course, we must not forget that the small set has got to be carefully built. The components must be the last word in efficiency, while any variations cannot be tolerated.

It is not wise to go to the other extreme and say that the best set is a one-valver. A two-valver perhaps, but never a "one" unless you intend to use

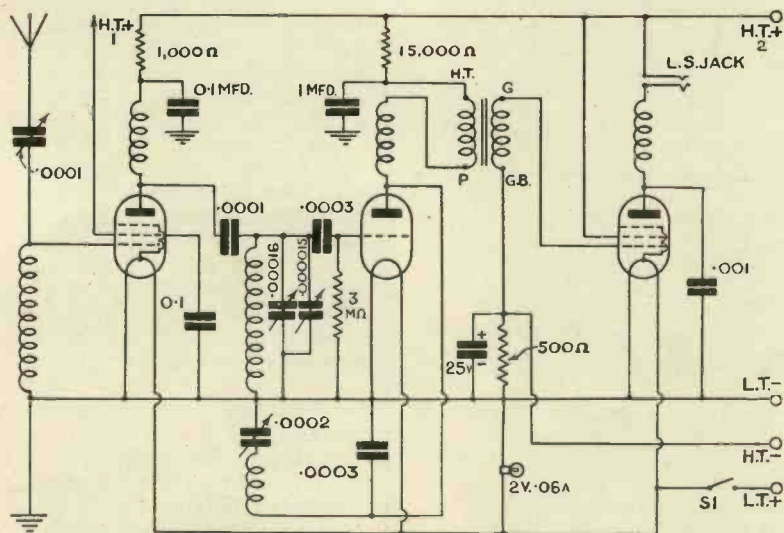

The circuit is very straightforward, but notice the band spread arrangement and the automatic bias circuit for the pentode.

:: High-frequency Gain to Below 20 Metres ::

it solely for C.W. reception. Several readers have used det. one's for years, obtaining marvellous results, but even so one point I have decided is, that a short-wave set without a high-frequency stage is not going to be one hundred per cent.

Take, for example, a typical two-valver. Even if it is loosely-coupled to the aerial, variations in aerial length will cause variations in dial readings. If you readjust the preset, the receiver has to be tuned all over again. If the aerial is too long, more than likely the

grid circuit will be heavily damped and the set will refuse to oscillate.

Of course, if you use a tuned aerial you can do some really good things with a two-valver, but taking amateurs as a whole, some of them cannot be bothered to go to such extremes as a tuned aerial, while others neither have the spare cash nor the facilities.

That is why a high-frequency stage in front of the detector is almost essential. I think it is a little better if it is tuned, but on the other hand there is the additional control which makes

tuning a little more complicated and the receiver less simple to calibrate.

Looking at it from every angle, the almost ideal receiver seems to be one with a single untuned high-frequency stage, triode leaky-grid detector and pentode output.

With a receiver of this type I can obtain a measurable high-frequency gain down to below 20 metres. This gain is quite useful, but I should not have worried if the high-frequency stage had been a passenger on this wave-band for it is so very useful in other ways. You can see from the circuit that the detector circuit is entirely isolated from the aerial. By that I mean the detector circuit damping is constant. There are no variations, the reaction is smooth and does not alter, while the tuning scale can be calibrated and it will stay fixed.

Aerial Selection

Within reason any alteration in aerial will not affect the tuning, so that if you are unable to use a really good short aerial, you need not worry very much about the receiver not oscillating. In addition to all these little points, there is a material increase in overall gain by the use of the high-frequency stage. This increase is more noticeable the lower the frequency. When you get up to the 3.5 or 1.7 mega-cycle bands, you really will notice how the high-frequency pentode pulls its weight.

This receiver was built for my own personal use and the components in it were all picked out for some reason or other. To give you an idea of what I mean, the Wearite high-frequency choke in the grid circuit of the high-frequency pentode was chosen because it is completely screened, automatically earthed, and has a very small field. A larger choke in this position is inclined to increase the amount of pick-up from the local station when the receiver is used in the London area. Then the valve holder; the special Bulgin holders used are on a really good insulating material and of very low capacity.

Another point in their favour is that the centre contact is brought out to two terminals on either side of the holder so it is very useful for negative connections and simplifies wiring.

The small T.C.C. mica condensers are compact, don't require any extra wire for connecting, while you cannot possibly improve on the efficiency of them—at least not at a reasonable figure.

As regards the high-frequency chokes in the anode circuit of the high-frequency pentode and detector valves, these were used because in practice they appear to be comparatively free from resonance. The effect is for the re-

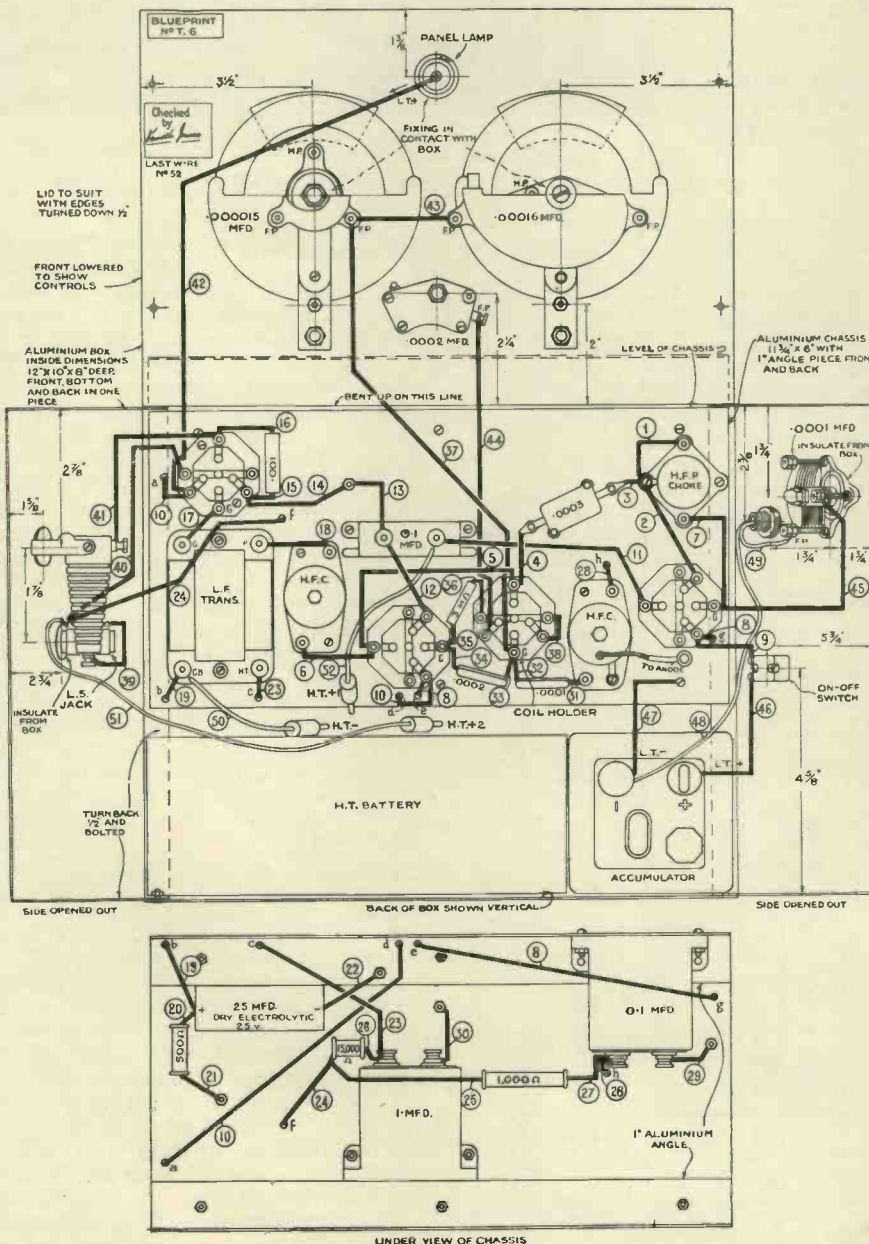

You can obtain a full-sized blueprint from our Blueprint Dept. if you have any difficulty in constructing the receiver from this reduced size print, price 1/6.

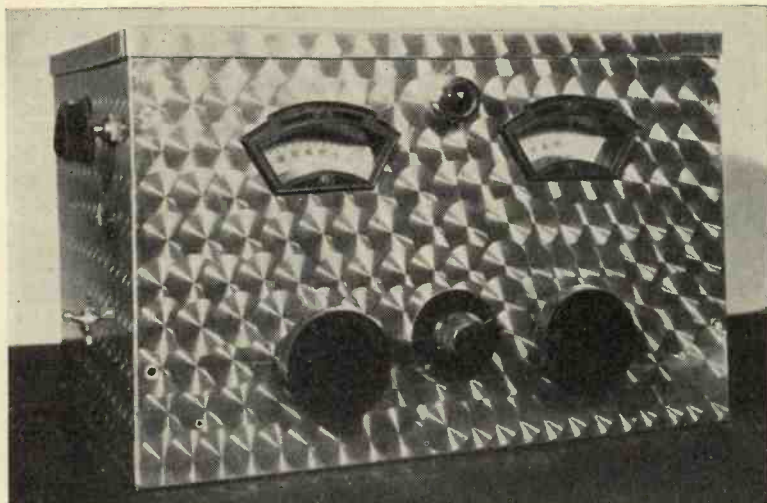

Tuning and general operation should not present any difficulties. On the left is the main tuner, with a miniature condenser for band spreading on the right. In the centre is the reaction condenser, also with a slow-motion drive.

ceiver to oscillate quite freely over all wavebands without peaks.

Components for the 1-V-1.

- BASEPLATE**
1—Aluminium 12 in. by 6 in. by 1 in. (Peto-Scott).
- CHOKES, HIGH-FREQUENCY**
1—B.T.S. short-wave screened with pigtail.
1—Wearite, type HFP.
1—B.T.S. short wave screened without pigtail.
- COILS.**
1—Set, home built (or B.T.S. or Stratton).
- CONDENSERS, FIXED**
1—.0001-mfd. (T.C.C., type M).
1—.0003-mfd. (T.C.C., type M).
1—.0002-mfd. (T.C.C., type M).
1—.001-mfd. (T.C.C., type tubular).
2—.1-mfd. (T.C.C., type 50).
1—2-mfd. (T.C.C., type 50).
1—25-mfd., 25-volt electrolytic (Ferranti, type CE82).
- CONDENSERS, VARIABLE**
1—.00016-mfd. (Eddystone, type 922).
1—.00015-mfd. (Eddystone, type 900).
1—.0002-mfd. (Eddystone, type 900).
1—.0002-mfd. (Eddystone, type 957).
- DIALS, SLOW MOTION**
2—Vernier discs (Eddystone, type 933W).
- HOLDERS, VALVE**
4—5-pin (Bulgin, type S.W.21).
- PLUGS, TERMINALS, ETC.**
1—Insulated (Clix, type 17).
1—Solid (Clix, type 16).
1—Spade terminal type 3 (Clix, marked L.T., positive).
1—Spade terminal type 3 (Clix, marked L.T. negative).
3—Wander plugs (Clix type 18, marked H.T. 1, H.T. 2, H.T.—).
- RESISTANCES, FIXED**
1—1,000-ohms (Erie, Amplion).
1—25,000-ohms (Erie, Amplion).
1—3-megohms (Erie, Amplion).
1—500-ohms (Erie, Amplion).
- SUNDRIES**
Connecting wire and sleeving (Goltone).
Thin flex (Goltone).
Insulating bushes (Eddystone).
1—2-volt .06 dial lamp (Bulgin).
Quantity of 6 B.A. nuts, bolts and washers.
Packet of bushing washers (Bulgin).
1—Jack, type J2 and 1—Plug type P15 (Bulgin).
- SWITCHES**
1—Bulgin type S104.
- TRANSFORMERS, LOW-FREQUENCY**
1—AF8 (Ferranti).
- ACCESSORIES.**
- CABINET**
1—12 in. by 10 in. by 8 in. with lid (Peto-Scott).
1—2-volt accumulator (Exide, type 1FGC).
1—Vidor 120-volt. H.T. Battery.
1—Pair Brown type A headphones.
- VALVES**
1—Cossor 210SPT.
1—Cossor 210Det.
1—Mazda Pen220A.
- Complete kits of parts are obtainable from Peto-Scott, Ltd.

Although quality is not frightfully important in a short-wave set, in view of the fact that some really good programmes are receivable and a moving-coil loud-speaker may be used, the small Ferranti AF8 low-frequency transformer was almost an automatic choice. This component does give very good quality without being unreasonable in price.

The tuning dials and condensers were chosen firstly because the dials are so very easy to read and are supplied with a hair-line, and secondly, Stratton tuning condensers are absolutely silent in operation. Even with the receiver smoothly oscillating, you can move the condensers as much as you like without any rustle being noticed.

Little Interference

You may wonder why the whole unit has been built in a metal cabinet, com-

plete with batteries and accumulator. The last receiver of this kind that I built had its power supply external and I picked up an annoying hum from the lighting and power circuit around my laboratory.

With this receiver hum is completely absent, and incidentally pick-up of local interference such as vacuum cleaners and driers, and even motor-car ignition systems is greatly reduced. With this set leads are all kept short, the dust is kept out, the whole outfit is very compact, and the result is that you can knock the receiver as much as you like without causing any rattle or vibration. Short-wave listeners will appreciate that point.

I was sorely tempted to make this receiver mains operated, but I decided after all that the majority of our readers make battery-operated sets, and in some cases prefer them on the short-waves. Anyhow a mains unit can be used in place of a dry battery, and in the majority of instances can be fitted inside the metal case.

Valves

Valves and coils are very important. In the high-frequency stage, use a Cossor pentode. It has a four-pin base and to all intents and purposes is exactly the same as a screen-grid valve. If you have not a pentode handy you can use a screen-grid such as the Cossor 215SG, Mullard PM12A and so on, but you will notice a distinct drop in gain. In the detector stage it is absolutely essential that the valve be noiseless and free from microphony. The metallised Cossor 210Det. used is excellent in these respects, but if you want a substitute, try the Ferranti L.2. This is not strictly a detector valve, but it works exceptionally well, and if you find a receiver a little obstinate as regards oscillating below 16 or 17 metres, this valve invariably does the trick.

In the output stage a pentode is essen-

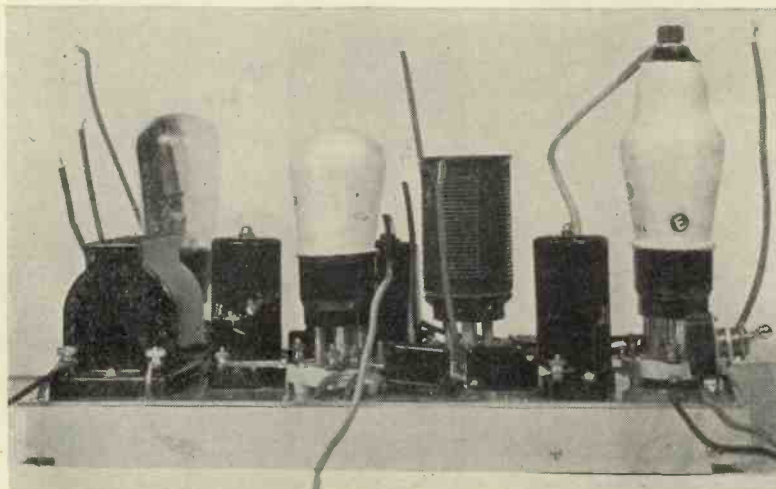

These are all of the components on the actual receiver chassis. Some fixed condensers and small resistances are mounted beneath the base plate.

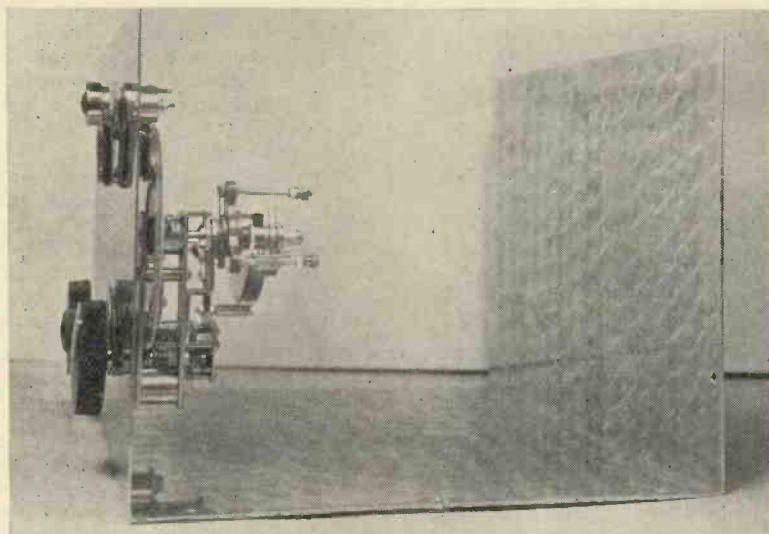

The cabinet is built in a special way. Notice the front and back are in one piece. This enables the components to be mounted on the front without any trouble.

tial, and *without* tone correction. This raises the pitch and makes it easier to read weak signals. The Pen220A gives about 800 milliwatts with a 120-volt battery, ample for most people and far too much for headphones, but you can if you wish substitute for it a Pen220.

This will save a lot of high-tension current for actually the Pen220A will badly overrun the battery that I have used. On the other hand a short-wave set is not used so very much so it is really a matter of personal taste which valve you use. By the way, if you use a pentode and a loud-speaker, you will probably want a fixed condenser across it to attenuate top notes. A good value for this condenser is .006-microfarad.

Construction

Unless you go about construction in a systematic manner, you will most probably have a little trouble. On the other hand, it can be so very simple if you know how.

First of all, take the separate chassis. You will find this is already drilled ready for you to fix the components on to it. On this chassis are four valve holders, three high-frequency chokes, four small fixed condensers, one large one, a low-frequency transformer, and a grid leak. These should all be firmly fixed.

On the under side of the chassis there are two fixed condensers of the paper type, and one 25-microfarad electrolytic, and three fixed resistances. All of these components can be wired up. You can also wire up the on-off

switch and connect the leads for the high-tension negative, high-tension plus one, low-tension positive and low-tension negative. Remember there is not any grid bias.

Then turn your attention to the actual cabinet. Take off the two sides, leaving the front, bottom, and back, and drill the necessary holes for the two tuning dials, the reaction condenser, and the pilot light. Then as the two sides are easy to get at, fit the series aerial condenser on the left-hand one, and drill a hole through which the aerial and earth leads go.

On the right-hand side mount the headphone jack and the Eddystone high-frequency choke. Don't forget that the series aerial condenser and the jack must be carefully bushed from the chassis.

When you have done that, put the sides back and carefully bolt these on. If you don't do that you will find that

after the set has been completed you will be unable to get at it to do any bolt tightening. Then push the chassis in. You will find that if it is pushed in at an angle it will all go in quite freely without fouling any of the condensers on the panel. Of course, you must not forget to wire up the chassis before it is put in. When you have done that you will not have any trouble in inter-connecting the chassis components with the controls on the panel.

The final high-tension positive connection comes off one of the contacts on the loud-speaker jack. In the wiring up see that there is only one connection from the pilot light, the other is automatically made when it is screwed to the panel. The chassis is not actually fixed to the cabinet other than by wiring, but you can if you like put a large bolt right through the chassis and cabinet to secure it. On the other hand, with a fat high-tension battery it cannot possibly move.

That completes the construction of the receiver.

H.T. plus 1 should be plugged in to the 60- or 70-volt tapping, H.T. plus 2, of course, going into the maximum tapping.

The aerial lead-in wire is connected directly to the series aerial condenser. The lead comes through the bush in the side of the cabinet. I have also omitted to use an earth terminal. It is really rather unnecessary for it is just as simple to connect the earth lead directly to the negative terminal on the accumulator.

Band-Spreading

Now as regards band-spreading, this really requires a lot of explanation—I will tell you all about it next month—but for the time tune the receiver something like this. Leave the right-hand condenser set to about 25 degrees. Tune

(Continued in 3rd column of page 76)

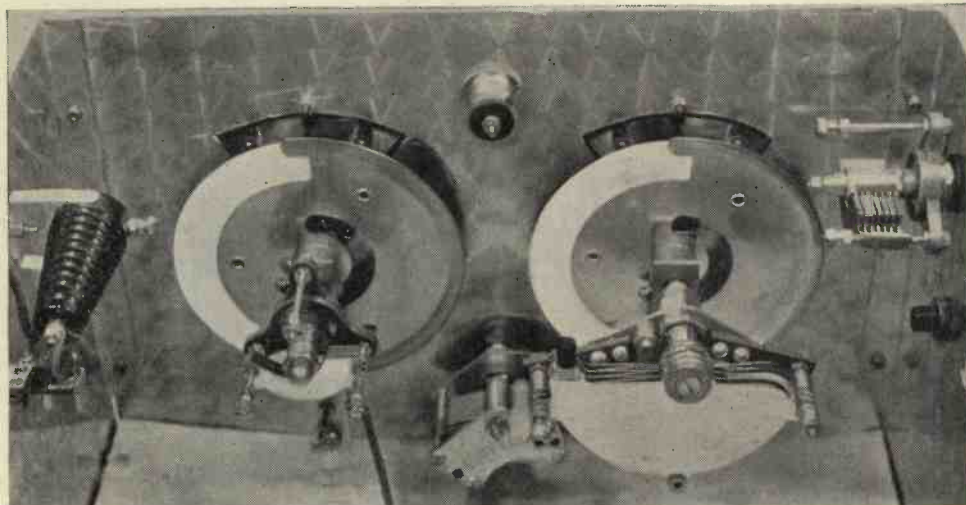

This shows just how the components on the panel are spaced. Note that the reaction condenser is kept away from the panel by means of a second fixing nut.

FEBRUARY, 1935

Multi-electrode Frequency Changers

Multi-grid oscillators have proved their worth in short-wave receivers. In this article we have shown the simplest way to use a heptode and how to introduce reaction and automatic volume control into the first detector circuit. You can use plug-in coils with our circuits, so greatly increasing their scope.

FREQUENCY-CHANGER valves in superheterodynes intended solely for short-wave work have been, until quite recently, simple oscil-

dyne are numerous and very striking. For instance, it is generally known that the autodyne arrangement functioned solely by virtue of the fact that circuits

duce a high noise level. Finally the conversion conductance of the triode is negligible and in addition it is a powerful radiator!

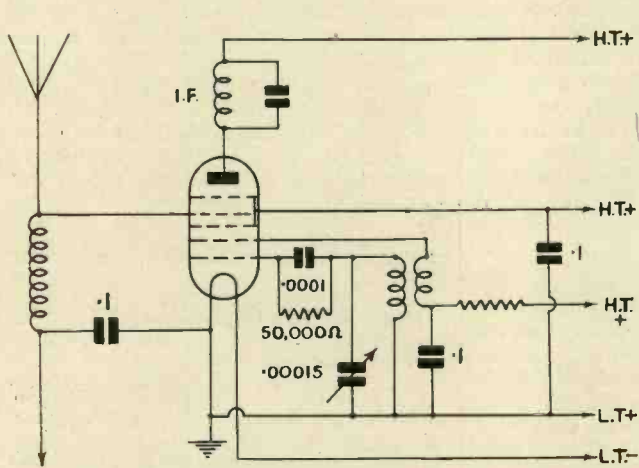

Fig. 1.—This straightforward heptode circuit can be used with home-built or plug-in type coils. Similarly the choke in the detector grid circuit can be replaced with a resistance.

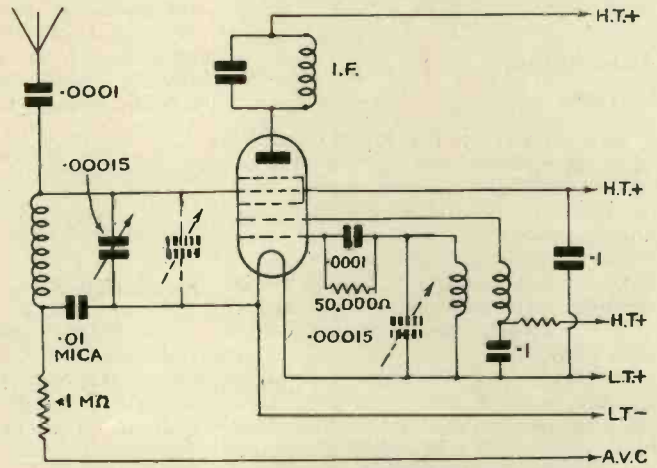

Fig. 2.—Results are infinitely improved when the detector grid circuit is tuned. This arrangement shows you how to do it and also shows the method of introducing automatic volume control.

lator-detectors in autodyne circuits. The introduction of multiple-electrode valves has opened a new field of experiment for the amateur. One of the most promising types of "mixer" is the heptode, which, in essence, is a triode and screen-grid or tetrode, all the electrodes being arranged concentrically around the filament. From the point of view of the electron stream these two valves are then in series. The tetrode section acts as detector or demodulator whilst the triode section serves as the local oscillator.

The advantages possessed by this comparatively new valve when compared with the older triode auto-

tuned to short wavelengths (of the order 10 to 50 metres) are of relatively high decrement or flat in tuning, thus enabling the grid circuit to be detuned from the signal frequency in use. [Whatever the intermediate frequency used, there are two oscillator frequencies which will give the required "beat," one either side of the signal frequency and every station is received in two positions. The aerial has to be loosely coupled to the oscillator coil to prevent damping or "dead-spots," and this loose coupling results in poor signal strength due to low input.

It must also be remembered that low input signals in a super-heterodyne pro-

Whistle-free Circuits

As a contrast to this gloomy picture, the heptode is singularly free from these troubles. In Fig. 1 this valve is shown in a typical simple short-wave circuit. The aerial is shown joined directly to the tetrode control grid, thus ensuring the maximum signal input. Despite this, the oscillator section of the valve is quite unaffected by the aerial coupling except at very high frequencies, where even the minute inter-electrode capacities offer a low reactance to the H.F. Because the oscillator section is undamped, the amplitude of oscillation remains fairly constant over a large frequency-band without "squegging." A single reaction winding wound correctly and disposed correctly to the grid coil will maintain oscillations from 6 megacycles to 10 megacycles, or four times the range of the medium-wave broadcast band, without any reaction adjustment. This valuable property makes for simplicity of controls on the receiver. No autodyne circuit will do this with anything like the ease of the heptode. No radiation from the aerial takes place as the triode section is isolated and electronically coupled.

The triode section oscillations modulate the electron stream at the frequency

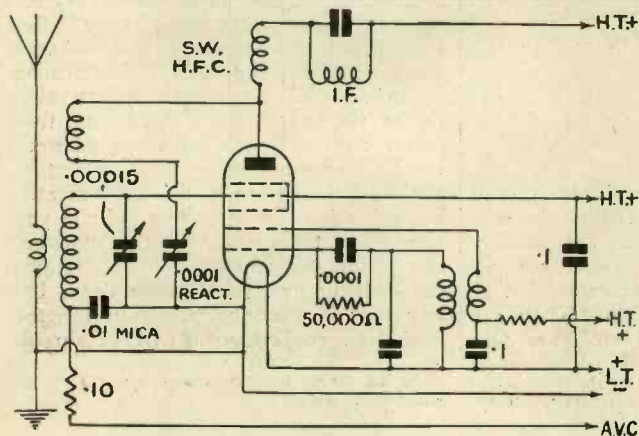

Fig. 3.—Reaction from the detector anode livens up the circuit besides having many other uses. The low value of reaction condenser is needed.

Valves that Prevent Re-Radiation

of oscillation, but as the tetrode must necessarily use the same stream, and as it is also being modulated at signal frequency, efficient "mixing" takes place.

In this first circuit an untuned or aperiodic aerial coil is shown for simplicity; naturally this system will not allow full advantage to be taken of "image" or "repeat point" suppression, consequently every station will be received at two settings of the oscillator condenser.

Tuned-input Circuits

Now in Fig. 2 the input circuit is tuned and the tetrode control grid has A.V.C. applied from the second detector position. Two tuning controls are now necessary but this will not make tuning any more difficult, because it will be found that the aerial tuning is extremely flat. It is in fact so flat that both circuits may be ganged with ease.

It is generally believed by the short-wave tyro that tuning on the short wavelengths is razor-like in its sharpness, and, whilst this is true of oscillating circuits, it is not due to any inherent selectivity of short wavelengths, but rather to the unsuitable values of components. The suppression of the image signal is directly proportional to the intermediate frequency used, or, in other words, better suppression is obtained by higher intermediate frequencies.

It is sufficient to say that with an intermediate frequency of even 500 kc. (600 metres) strong suppression of the image signal will not be apparent. The difference between signal-frequency and oscillator circuits is still a long way from being great enough for one tuned circuit to give complete suppression, although it will be definitely noticeable on rather strong signals.

Feedback in Detector Circuit

An apparent increase in difference between the two tuned circuits can be obtained by a rather simple procedure. Reference to Fig. 3 will show an identical circuit with Fig. 2, with the exception that a reaction winding and control has been added to the tetrode section. This simple addition will enable the damping of the tuned circuit to be reduced almost to zero, considerably sharpening the tuning and making ganging more critical. It is in fact advisable to add a trimmer condenser of say 25 micro-microfarads in parallel with the aerial-tuning condenser.

The direct aerial coupling to the con-

trol grid can no longer be used because natural resonance points of the aerial system will result in reduction of feedback and "squegging" in the tetrode section at certain points on the scale. To avoid continual adjustment of the supplementary control the amount of feedback should be fairly constant, and this can only be obtained by loosely coupling the aerial as shown.

Incidentally it has been found that the use of the screening-grid instead of the anode as the source of H.F. to feed back to the control grid circuit results in a slightly more stable arrangement. Do not in any circumstances allow the tetrode section to oscillate, otherwise all stations will have a continuous heterodyne superimposed. The reaction should always be on the verge of oscillation.

No Radiation

The gain in selectivity and complete freedom from "dead-spots" in the tuning stage, together with absence of radiation is a sufficiently complete justification for the use of the multi-grid oscillator. But there are still more very important points, not the least being the real stage gain of the demodulator section.

No one ever expected any actual amplification of signal from the triode autodyne—it was sufficient if it demodulated. With the heptode there is a very satisfactory conversion conductance available, which is only a potential gain, unless full use is made of good quality intermediate-frequency transformers having high dynamic resistance. All conversion conductance figures quoted by the makers can be used for short-wave calculations of gain with fairly accurate results.

It might be pointed out that quite a lot of time could be profitably spent on investigating different oscillator circuits in the triode section. Those shown in the figures accompanying this article all make use of a separate reaction winding. Should it be desired to change wavelength by switching, six contacts in all have to be broken (including the aerial coil).

Simple Switching

If some more simple oscillator circuit is used, it is possible to reduce the contacts to five or even four, but nothing less. Variations of the Hartley oscillator are particularly recommended as being worthy of attention. They are simple, use one tapped coil, are free from any high amplitude harmonics, and are possessed of relatively good

frequency stability, preventing drift and disalignment of ganging.

"Squegging" can be overcome by the use of a suitable series feed resistance to the triode anode. On the other hand failure to oscillate at the upper end of certain bands is due to unfavourable L/C ratios and can be overcome by using a smaller maximum value of condenser and more coils or ranges, or by improving the "mu" of the triode section. This latter is effected by connecting externally an "HL" type of valve across the triode section of the heptode. Electronic mixing is still in operation with this arrangement.

Sufficient has been said to point out the many advantages of this new valve in its application to short-wave work, which will be confirmed in actual experiment.

"The I-V-I Band-Spread Receiver"

(Continued from page 74.)

on the left-hand condenser until you come to the bottom of your required waveband, say, for example, 19 metres. When you tune in W2XAD, tune back about 10 degrees and then do the remainder of the tuning with the right-hand band-spread condenser. You will find that this condenser will only alter the tuning about two metres over the whole of its travel,

You will be able to gauge from these readings just whereabouts the stations will come in. For example, on the first band between 12 and 28 metres, you know very well that the 13-metre American stations should be round about 10 to 15 degrees, whereas the 25-metre bands will be somewhere round about 150 degrees. And that gives you the 19-metre band on approximately 80 degrees, and the 15-metre band on 45 degrees. You can work out the wavelength of the other stations in just the same way.

After you have tested the receiver and found out just how to handle it, try for American reception, any time after lunch, but choose the 13-metre band. During the early part of the afternoon up to about 18.00 confine your attention to the 16- and 19-metre bands and to a lesser degree to the 20-metre amateur band. The 20-metre band is rather variable, but from 5 o'clock onwards reception is usually quite good. If you like getting up early in the morning the 75-metre American phone stations are coming over well these days, but any way if you are going in for the B.E.R.U. contest, you will be up all day and all night, whether you like it or not.

The Short-wave Radio World

A Separately-Tuned Converter

*Padding rendered unnecessary—
diversed capacity used*

We notice in the current number of *Radio World* a two-stage converter for A.C. or D.C. mains. As a modulator one of the new 6C6 tubes is used with a type-76 triode as an oscillator and a 1-V half-wave rectifier.

The modulator is coupled to the oscillator by means of a small capacity of 6 micro-microfarads, obtained by twisting together two lengths of 1-mm. flexible wire. The output is taken through a medium-wave transformer

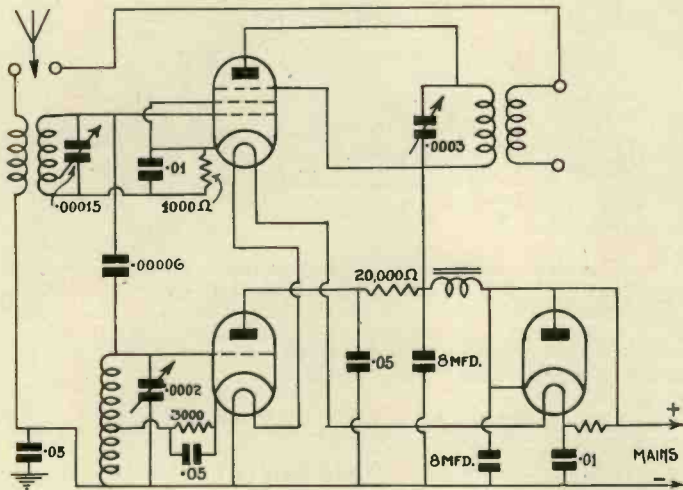

used backwards so as to peak. The primary is the large winding and is tuned. This unit covers four wavebands, ranging from 1,600 to 30,550 kilocycles.

Using 1.75-in. diameter tuning coils, four are required, having inductances of 80, 14.5, 3.5 and .85 micro-henries for the modulator circuit, and four more coils having inductances of 65, 16, 4.4 and 1.3 micro-henries, for the oscillator section. This unit can be constructed from British-made components with the exception of the two tuning condensers. However, a 160 micro-microfarad Eddystone condenser can be substituted for the 124.5 micro-microfarad recommended, while a 100 micro-microfarad Eddystone is a suitable substitute for the 90 micro-microfarad oscillator tuning condenser suggested. Users of A.C. or D.C. broadcast receivers will find this circuit helpful for short-wave reception.

A One-valve All-wave Loud-speaker Set

Even though we are used to hearing of multi-valve American receivers, Americans are still keen to build un-

A Review of the Most Important Features of the World's Short-wave Literature

usual one- and two-valve receivers. Referring to the current number of *Radiocraft* we find an all-wave receiver for loud-speaker reception using one only of the type-19 valves. This valve is of class B construction; the filament rating is 2 volts, .26 ampere. It gives

A radio-frequency pentode and a triode oscillator are used in this two-stage converter circuit, which is suitable for A.C. or D.C. mains.

a high output from only 135 volts high-tension.

One-half of the class B valve is used as a triode oscillating detector, while the other half is used as a triode output valve. Plug-in coils of the four-pin type enable the receiver to be used on any wavelength. Control

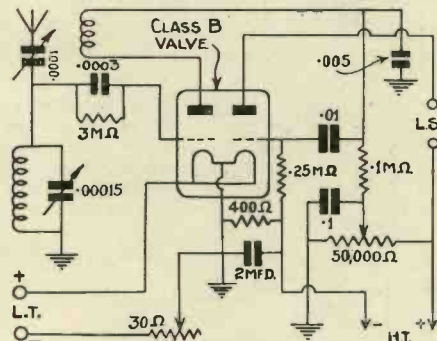

By using a type-19 class B valve this one-valve all-wave receiver will give loudspeaker volume.

of reaction is obtained by means of a 50,000-ohm variable resistance. This method enables very smooth adjustment to be obtained and the maximum re-

sults are given without trouble, particularly on short waves.

In series with the aerial is connected a 35 micro-microfarad variable condenser, which is necessary to reduce aerial damping on short waves and to give a high degree of selectivity on medium waves.

English valves such as the Mullard PM2BA or Mazda PD220A are quite suitable.

Remote Control for the Transmitter

Those who do not read Q.S.T. will have missed an interesting system of remote control for the transmitter. The arrangement developed by W9WC has been designed so that the filaments of the transmitter valves are brought into circuit when the receiver power supply is turned on by means of the relay, actually a motor car generator cut-out, re-wound to operate on about 10 milliamps.

In normal circumstances this control system uses two push-buttons—one to start and one to stop—and in these conditions the switch "S.W." remains closed. Current to operate the relays is taken from the receiver current supply and the relays are wound to operate from 22 volts at 10 milliamps.

When the start button is closed the relays RY₁ and RY₃ are energised. RY₃ has two sets of contacts, one a make and the other a break set. The break set cuts the negative high-tension lead to the receiver and the make set locks the relay in the closed position.

The relay RY₁ has two sets of contacts that make when closed—one set is used to lock the relay and the other set to close the primary of the transformer for the oscillator doubler and buffer.

As the anode current comes up to normal in the buffer stage it closes relay RY₂. The final amplifier and modulator only comes on when getting excitation because of the operation of this relay.

The stop-button supplies the voltage to the relays opening the contacts, so cutting out the transmitter and breaking the negative lead of the high-tension to the receiver.

A Five-metre Transceiver

A Novel Battery-operated Phone Transmitter and Ultra-short wave Receiver.

A. G. Heller, chief engineer of the Insuline Corporation in America, has designed a very compact two-valve Transceiver for battery operation. Although it uses American components throughout it can easily be built by the English amateur.

5-metre Transceiver :: Remote Control for Transmitter :: Grid-current Modulation

The oscillator is a type-37 valve, which is almost identical with the Mazda AC/HL. The combined modulator and amplifier is a 41 valve, which closely approximates the Mazda ACz/Pen. This is a steep-slope multi-

With the switch in the send position, the 37 valve works as an oscillator and the 41 as a modulator, coupling back to the anode of the oscillator valve (plate modulation).

The microphone transformer has, in

almost automatic on five metres. The tuning characteristics of such a circuit are essentially broad and, since the frequency drift or shifting of an oscillator on five metres is considerable, it is obvious that such a broad tuning circuit

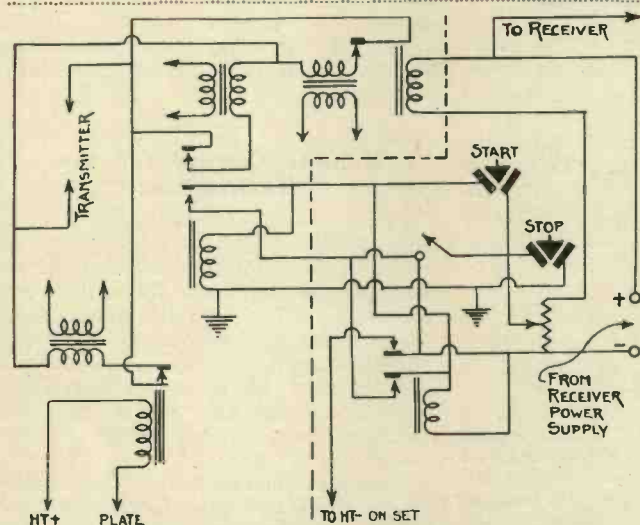

This arrangement is almost entirely automatic and controls all supply voltages both to receiver and transmitter.

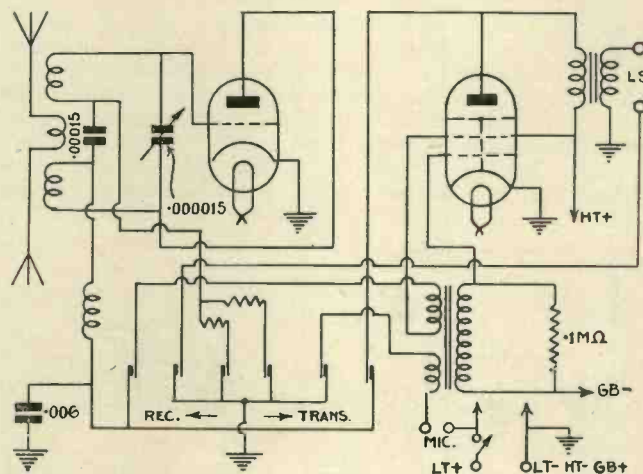

Two valves only are used in this combined receiver and transmitter: it is designed for 56 Mc. working.

electrode valve, giving a high output with only a very small grid input. You will see from the circuit that with the switch set for reception, the oscillator valve functions as a super-regenerative detector, while the 41-type valve becomes a simple low-frequency amplifier.

In addition to the single-button microphone winding, another primary for coupling to the 41 valve. It is introduced into the circuit when the switch is in the received position.

Selection of a super-regenerative detector circuit for five-metre working is

will materially aid in keeping the signals tuned in.

Grid-current Modulation

Grid-current modulation, which is so widely used in the States, has not yet achieved full popularity over this side. There are two methods of obtaining grid-modulation: (1) by fixing the static grid bias and applying an input amplitude modulated wave to the grid, and (2) by driving the grid at constant amplitude and varying the amplified grid bias at the signal frequency.

Such a change of bias can be effected in two ways, by adding the signal direct through a transformer, or by introducing the valve as a grid leak and varying its resistance by the modulating signal. This system is shown in Fig. 5.

This arrangement is in addition an efficiency control as with all other low-power systems, so no saving of power is achieved. It is, however, a useful method of modulation for certain classes of work. Where telephony is needed only as a second consideration, and a quick change-over is required, then it performs very well indeed. Alternatively, when a wide signal-frequency band-width is required, it is again satisfactory for this type of circuit that there are no limitations of frequency response such as is found with choke-control systems.

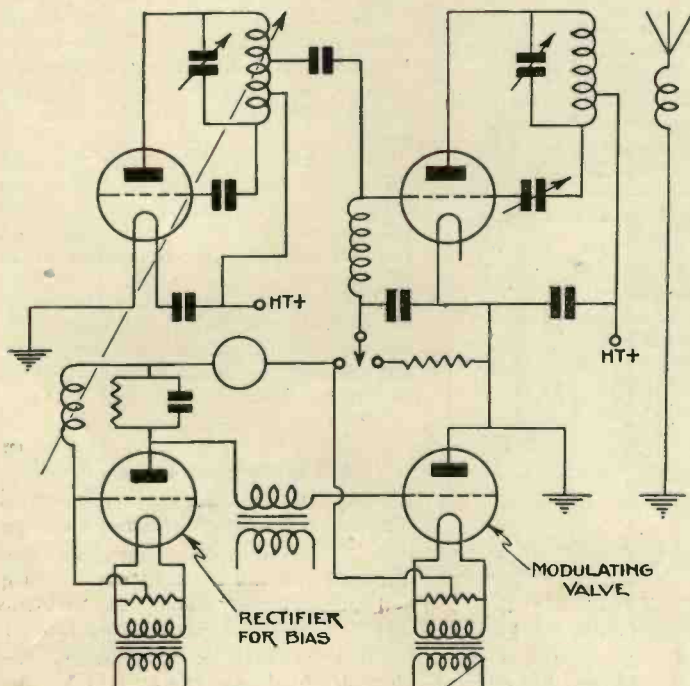

Grid modulation is claimed to give even better results than Heising modulation —this is a good circuit.

THE AMATEUR TELEVISION EXPERIMENTER

THE IMPORTANCE OF THE AMPLIFIER

SOME GENERAL POINTS IN DESIGN

This article is the fifth of a series dealing with the design of television apparatus for experimental purposes. The series has been written by two engineers who are actively engaged in television research.

WHATEVER the amateur television experimenter intends to experiment with, it will be necessary to have amplifiers, both for radio frequencies and, for want of a better name, television frequencies.

To begin with we will take the general principles of one for television frequencies. The essential requirements are (1) effectively level frequency response over the necessary band width; (2) a minimum phase distortion over the given band width; (3) low noise level (valve and resistance); (4) stability.

Such matters as economic construction and operation

to us all as R.C. coupled. Such a circuit is simplicity itself and from a television point of view very good or bad according to the values of the different components.

The first thing to consider is the potentiometer effect of a condenser and resistance in series. Turning to Fig. 1, only a part of the input voltage E is applied to the grid of the valve V_1 , namely, ER ; that of EC is lost. Now the resistance R , if of the right physical construction, remains of constant value at all frequencies, while the condenser C increases in resistance, or reactance at it is termed, as the frequency becomes

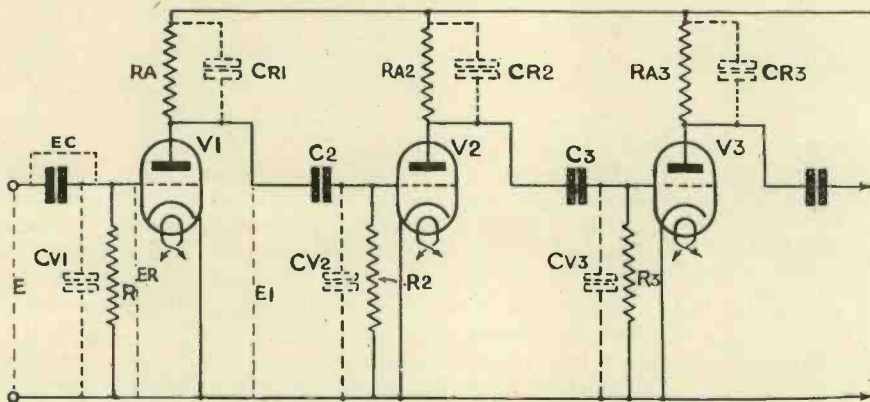

Fig. 1. A circuit of a typical three-stage resistance-capacity coupled amplifier.

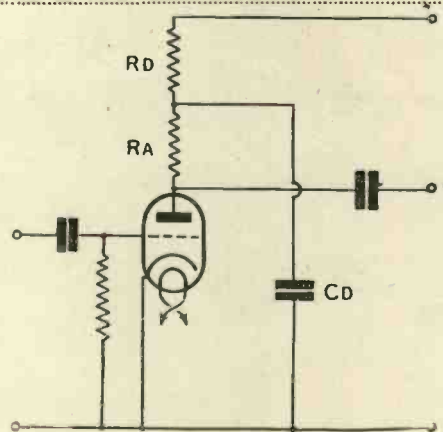

Fig. 2. Method of decoupling valves.

while from the experimenter's pocket point of view are very essential, should not be carried to such a point as to cause the apparatus to give unsatisfactory results. The old axiom "Do not spoil the ship for a ha'porth of tar" is very true in television work.

Having decided on the band width we wish our amplifier to pass and the degree of amplification desired, the first thing to decide is what class of valve to use, the directly or indirectly-heated type. The latter is definitely to be recommended, as almost without exception it has better characteristics, though, of course, its higher filament consumption is somewhat of a drawback unless mains are available. Also it is considerably less microphonic.

Phase

Distortion

The greatest problem of design is that of phase distortion. Some experimenters imagine that if the frequency response of their amplifier is level, phase distortion has been taken care of. Of course, nothing is further from the truth.

Fig. 1 is a circuit of a three-stage amplifier, known

lower and in consequence, say, at 25 cycles less of the voltage E is passed to the grid of V_1 , than, say, at 1,000 cycles.

Wiring Capacities

In parallel with R is Cv_1 , which represents the valve and wiring capacities of which the former is by far the most serious. This valve capacity is rather complex and is expressed by

$$C_{pg}(u + 1) + C_{gf}$$

Where C_{pg} = grid plate capacity.

C_{gf} = grid filament capacity.

U = the dynamic amplification factor of the valve.

This capacity Cv_1 will effectively lower the value of R as the frequency increases. Now what has been said of $C-R-Cv_1$ circuit is also true of $C_2-R_2-Cv_2$, but here the total impedance of the circuit, which being in parallel with R_A will affect the dynamic amplification factor of the valve V_1 . At low frequencies the impedance of $C_2-R_2-Cv_2$ is increased while reducing the proportion of available volts E_1 across the grid of V_2 , the

PHASE DISTORTION IN TELEVISION AMPLIFIERS

dynamic amplification factor of V_1 will be slightly increased; at high frequencies the reverse will take place owing first to the lower impedance of C_2 and later Cv_2 . All this while lowering the dynamic amplification of V_1 will in consequence decrease the value of Cv_1 .

From what has been stated it will be apparent that the effective valve capacities of V_2 — Cv_3 will actually affect the value of Cv_1 . Unfortunately, what is lost on the swings cannot be made up on the roundabouts, and to avoid attenuation of the higher frequencies the valve capacities must be kept small, which means the stage gain per valve must be considerably less than is normal for sound amplifiers.

An important point is that the valves should be of low internal impedance so that with low anode resist-

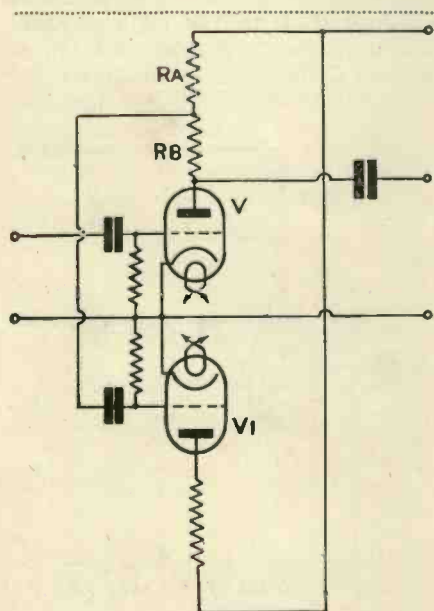

Fig. 3. A stage of push-pull.

ances the dynamic amplification is a reasonable proportion of the valve amplification factor, and thereby reducing the shunting effect of the valve capacities which becomes decreasingly effective, for a given frequency, the lower the anode impedance.

If Cv_2 equalled .000089 mfd., a value for a certain triode valve working at a stage gain of 17.5, it is interesting to note the effect on an anode impedance of 10,000 ohms. At 20,000 ~ the anode would be reduced to 9930.4 at 50,000 ~, 9626 and 500,000 ~ to 3,333. Obviously for present-day low-definition quite satisfactory, but useless for television of the future. The valve capacity is probably best reduced by the use of a pentode type of valve whose grid-anode capacities are of the order of .005 mfd. as against 5 mfd. of the average triode.

In Fig. 1 the capacities of $CR_{1,2}$ and 3 are the self-capacities of the anode resistances, which all help to reduce the high frequencies. It is hard to get any figures for these as so much depends on their physical construction. Where possible the metallised type should be used as all commercial wire-wound resistances have a relatively high self-capacity. Another capacity point to note is that the capacity of the plates

of coupling condensers to their cases, if of metal, is quite high and if the cases are mounted on an earthed metal chassis results in quite an amount of unnecessary frequency attenuation.

In the circuit, Fig. 1, the current in RA and RA_1 is either increasing or decreasing together and should there be a common resistance in the H.T. supply, the voltage developed may feed back into the anode circuit of V_1 and the whole amplifier break into oscillation. This will certainly happen unless the H.T. supply is a very low impedance, so unless this is the case each valve must be decoupled as in Fig. 2, and this may completely ruin the characteristics of the amplifier for television at the lower end of the frequency band.

A general survey of the value of CD one finds is that of 2 mfd., while the resistance RD is chosen so that the total voltage drop across RD and RA leaves (if possible) the maximum H.T. voltage suitable for the valve used (RA having been chosen to give the required dynamic amplification).

Now assuming RA 10,000 ohms, RD 10,000 and CD 2-mfd. Omitting CD the stage gain is

$$\frac{RA + RD}{RV + RA + RD} \times u$$

where RV is the A.C. resistance of valve and u the amplification factor.

On connecting CD , RD is shunted more or less according to frequency. At 200 ~ the reactance of CD is 400 ohms, which for practical purposes removes RD from the stage-gain formula, but at 25 cycles CD equals 3,200 ohms and is by no means negligible; in consequence it increases the stage gain, but at the same time introduces phase distortion.

It is a rough, though fairly safe rule, to make CD of such a value that at the lowest working frequency it will have a reactance of not more than .083 of RD ; the same can be said of the coupling condenser and grid leak.

Push-Pull

Some experimenters in order to avoid the decoupling problem, use a push-pull arrangement, of which one stage is shown in Fig. 3. Here RA , RB are the anode load which is suitably divided so that the voltage applied to the grid of V_1 is equal to that applied to V_2 , but, of course, is opposite in phase. Such a system requires double the number of valves and large current supplies and is probably rather beyond the average amateur experimenter.

Those readers who have back numbers of TELEVISION should refer to "Resistance-coupled Amplifiers," March, 1933, "Phase Distortion," April, 1934, both by Robert Desmond, and those who wish a mathematical approach of the problem are well advised to refer to "Some Calculations of Stage Gain and Phase Angle in Resistance-coupled Amplifiers," by T. H. Bridgewater, in the January-March, 1934, "Proceedings of the Institute of Wireless Technology."

Phase distortion will be discussed again when practical arrangements for measuring this will be described. Automatic grid-bias introduces phase distortion and other complications, and for which experimental apparatus is not worth while on any account.

The Television Committee's Report



The Report of the Television Committee was presented by the Postmaster General to Parliament on Thursday, January 31st. The Committee consisted of THE RIGHT HON. THE LORD SELSDON K.B.E. (*Chairman*). SIR JOHN CADMAN, G.C.M.G., D.Sc. (*Vice-Chairman*). COL. A. S. ANGWIN, D.S.O., M.C., B.Sc., Assistant Engineer-in-Chief, General Post Office. NOEL ASHRIDGE, B.Sc., Chief Engineer, British Broadcasting Corporation. O. F. BROWN, M.A., B.Sc., Department of Scientific and Industrial Research. VICE-ADMIRAL SIR CHARLES CARPENDALE, C.B., Contoller, British Broadcasting Corporation. F. W. PHILLIPS, Assistant Secretary, General Post Office. *Secretary*: J. VARLEY ROBERTS, M.C., of the General Post Office. Its appointment had been announced in the House of Commons on March 13th, 1934, with the following terms of reference: "To consider the development of Television and to advise the Postmaster General on the relative merits of the several systems and on the conditions under which any public service of Television should be provided."

The Committee examined thirty-eight witnesses; consulted with members of various Departments of the Government; received numerous written statements regarding television from various sources; received much formal evidence containing secrets of commercial value, which evidence will not be published;

inspected all the different television systems belonging to firms who were prepared to provide demonstrations, the most distinctive being those of the Baird, Cossor, Marconi-E.M.I. and the Scophony Companies; other organisations which gave evidence were Ferranti, General Electric, Plew Television, the B.B.C., the Newspaper Proprietors' Association, the Radio Manufacturers' Association, the Television Society, whilst a number of other interests—this journal among them—presented written evidence. In America, the delegation visited and inspected many of the chief centres of television experimental research, as well as the plant and laboratories of the principal Broadcasting, Telephone and Telegraph Authorities. They had also the advantage of consultation in Washington with the Federal Communications Commission. In Germany, the delegation inspected the experimental installations belonging to the Reichspost and also of those of several private firms in Berlin.

In these pages, which the reader will understand we have added to TELEVISION AND SHORT-WAVE WORLD at the very last moment possible, we reproduce the greater part of the Report and the reader can be confident that we have not omitted anything of moment; we shall take an opportunity in our next issue of commenting on the Report and explaining any point that may need such treatment.

Advisory Committee Formed

The Advisory Committee already announced comprises Lord Selsdon (*Chairman*); Sir Frank Smith, Secretary of the Department of Scientific and Industrial Research (*Chairman of Technical Sub-Committee*); Colonel Angwin, Assistant Engineer-in-Chief of the Post Office; Mr. Noel Ashbridge, Chief Engineer of the B.B.C.; Vice-Admiral Sir Charles Carpendale, Contoller of the B.B.C.; and Mr. F. W. Phillips, Assistant

Secretary of the Post Office. The Secretary will be Mr. J. Varley Roberts of the Post Office. The Committee's task is to advise the Postmaster General on points arising in connection with the initiation and development of the broadcast television service.

The Advisory Committee will get to work immediately so as to lose no time in giving effect to the leading recommendations made in the report.

Summary of the Committee's Recommendation

The Committee's principal conclusions and recommendations are summarised below:—

(1) No low definition system of television should be adopted for a regular public service.

(2) High definition television has reached such a standard of development as to justify the first steps being taken towards the early establishment of a public television service of this type.

Operating Authority.

(3) In view of the close relationship between sound and television broadcasting, the Authority which is responsible for the former—at present the B.B.C.—should also be entrusted with the latter.

Advisory Committee.

(4) The Postmaster General should forthwith appoint an Advisory Committee to plan and guide the initiation and early development of the television service.

Ultra-short Wave Transmitting Stations.

(5) Technically, it is desirable that the ultra-short wave transmitting stations should be situated at elevated points and that the masts should be as high as practicable.

(6) It is probable that at least 50 per cent. of the population could be served by 10 ultra-short wave transmitting stations in suitable locations.

Patent Pool.

(7) It is desirable in the general interest that a comprehensive Television Patent Pool should eventually be formed.

Initial Station.

(8) A start should be made by the establishment of a service in London with two television systems operating alternately from one transmitting station.

(9) Baird Television, Limited, and Marconi-E.M.I. Television

Company, Limited, should be given an opportunity to supply subject to conditions, the necessary apparatus for the operation of their respective systems at the London station.

Subsequent Stations.

(10) In the light of the experience obtained with the first station, the Advisory Committee should proceed with the planning of additional stations—incorporating any improvements which come to light in the meantime—until a network of stations is gradually built up.

(11) The aim should be to take advantage, as far as possible, of all improvements in the art of television, and at the same time to work towards the ultimate attainment of a national standardised system of transmission.

(12) The cost of providing and maintaining the London station up to the end of 1936 will, it is estimated, be £180,000.

(13) Revenue should not be raised by the sale of transmitter time for direct advertisements, but the permission given in the B.B.C.'s existing Licence to accept certain types of "sponsored programmes" should be applied also to the television service.

(14) Revenue should not be raised by an increase in the 10s. fee for the general broadcast listener's licence.

(15) There should not be any separate licence for television reception at the start of the service, but the question should be reviewed later in the light of experience.

(16) No retailer's licence should be imposed on the sale of each television set, but arrangements should be made with the trade for the furnishing of periodical returns of the total number of such sets sold in each town or district.

(17) The cost of the television service—during the first experimental period at least—should be borne by the revenue from the existing 10s. licence fee.

Details of the Report

LOW DEFINITION TELEVISION.

As far back as the autumn of 1929 the B.B.C. gave the Baird Company facilities for experimental transmissions of television from a broadcasting station. During the next two or three years a large number of experimental transmissions were carried out by the Baird Company independently, as well as in liaison with the B.B.C.

Improvements were gradually made in the system, and in August, 1932, the Corporation arranged with Baird Television Limited for public experimental transmissions from their London Station (Brookmans Park) of television on a wavelength of 261 metres, and of the accompanying sound on a wavelength of 398 metres from the Midland Regional transmitter (Daventry). The Corporation agreed to provide special programme material and also staff for operating the television apparatus, which was installed in Broadcasting House by the Baird Company on a loan basis. These transmissions, the experimental nature of which was emphasised in a notice issued to the Press, have continued up to the present time, although their frequency has been reduced since 31st March, 1934, to two half-hour periods a week which are extended to three-quarters of an hour when circumstances permit.

In the case of these transmissions the size of the elements (elementary areas) composing the picture is such as to admit of transmission being effected in a series of thirty lines per picture and each picture is repeated $12\frac{1}{2}$ times per second.

Any pictures built up with a structure of the order of thirty lines are, however, comparatively coarse in texture. Little detail can be given, and generally speaking the pictures are only fitted for the presentation of "close-ups"—e.g., the head and shoulders of a speaker—and the quality of reproduction leaves much to be desired. Moreover, any frequency of the order of $12\frac{1}{2}$ pictures per second gives rise to a large amount of "flicker."

Whilst low definition television has been the path along which the infant steps of the art have naturally tended and, while this form of television doubtless still affords scientific interest to wireless experimenters, and may even possess some entertainment value for a limited number of others, we are satisfied that a service of this type would fail to secure the sustained interest of the public generally. We do not, therefore, favour the adoption of any low definition system of television for a regular public service. We refer later to the question of the temporary continuance of the present low definition transmissions pending the institution of a public television service of a more satisfactory type.

HIGH DEFINITION TELEVISION.

With a view to extending the application of television to a wider field and thereby increasing its utility and entertainment value, much attention has been given in recent years to the problem of obtaining better definition and reduced "flicker" in the received pictures.

The degree of definition it is essential to obtain is necessarily a matter of opinion, but the evidence received and our own observations lead us to the conclusion that it should be not less than 240 lines per picture, with a minimum picture frequency of 25 per second. The standard which has been used extensively for experimental work is 180 lines, but we should prefer the figure of 240 and we do not exclude the possible use of an even higher order of definition and a frequency of 50 pictures per second.

To attain such degrees of definition and picture frequency, very high modulation frequencies are required, which in practice can only be handled by radio transmitters working on ultra-short waves the effective range of which is much more restricted than the range of the medium waves used for ordinary sound broadcasting.

For the reception of high definition pictures the cathode ray tube is now usually employed. The cathode ray tube receiver involves no moving parts, and the picture is presented as a fluorescence at the end of the tube. A stream of electrons (particles of negative electricity) is projected along the tube, and impinges on a coating of fluorescent material at the end of the tube, the impact of the electrons on the fluorescent material causing illumination. The amount of illumination can be controlled by varying the flow of electrons, and the point of impact can be changed by deflecting the jet by means of electric or magnetic forces. The jet is modulated or controlled in amount by the received signal, and suitable electrical circuits are provided to move the point of impact in exact synchronism with the transmitter.

The size of the picture produced naturally depends upon the size of the cathode ray tube. At present the most usual size gives a picture of about 8 in. by 6 in., although good results have been seen with larger tubes. The apparent size can, of course, be increased by viewing the tube through a suitable fixed magnifying device, though with a corresponding loss of definition. Experimental work is proceeding with a view to the projection of pictures on a screen of much larger dimensions, but this is still in an early stage of development.

We are informed that the price to the public of a receiving set capable of producing a picture of about the first-mentioned size, with the accompanying sound, would probably at first be considerable, and various estimates have been given ranging from £50 to £80; but it is reasonable to assume that, if and when receivers were made on a larger scale under competitive conditions, this price would be substantially reduced.

Most of the high definition television systems follow in broad outline the methods of transmission and reception referred to above, with some variations in technique. We are impressed with the quality of the results obtained by certain of these systems, and whilst much undoubtedly remains to be done in order to render the results satisfactory in all respects, we feel that a standard has now been reached

which justifies the first steps being taken towards the early establishment of a public television service of the high definition type in this country.

THE PRESENT 30-LINE SYSTEM.

As regards the existing low definition broadcasts, these no doubt possess, as we have said, a certain value to those interested in television as an art, and possibly, but to a very minor extent, to those interested in it only as an entertainment. We feel that it would be undesirable to deprive these "pioneer lookers" of their present facilities until at least a proportion of them have the opportunity of receiving a high definition service. On the other hand, the maintenance of these low definition broadcasts involves not only some expense, but also possibly considerable practical difficulties. We can only, therefore, recommend—

(1) that the existing low definition broadcasts be maintained, if practicable, for the present; and

(2) that the selection of the moment for their discontinuance be left for consideration by the Advisory Committee.

with the observation that, if practicable so to maintain these broadcasts, they might reasonably be discontinued as soon as the first station of a high definition service is working.

SCOPE OF TELEVISION AND ITS RELATION TO SOUND BROADCASTING.

In our opinion there will be little, if any, scope for television broadcasts unaccompanied by sound. Television is, however, a natural adjunct to sound broadcasting and its use will make it possible for the eye as well as the ear of the listener to be reached. Associated with sound it will greatly enhance the interest of certain of the existing types of broadcast and will also render practicable the production of other types in which interest is more dependent upon sight than upon sound.

We are of the opinion that there are two factors which for a number of years will tend to prevent a television service being made use of to the same extent as present day sound broadcasting—

(1) The difficulties of wireless communication on ultra-short wavelengths, particularly in hilly districts, may seriously limit the extent to which the country can be effectively covered.

(2) Some time is likely to elapse before the price of an efficient television receiver will be comparable with that of the average type of receiver now in use for sound broadcasting.

Nevertheless, the time may come when a sound broadcasting service entirely unaccompanied by television will be almost as rare as the silent cinema film is to-day. We think, however, that in general sound will always be the more important factor in broadcasting. Consequently the promotion of television must not be allowed to prevent the continued development of sound broadcasting.

No doubt the evolution of television will gradually demonstrate the possibility of its application for many purposes other than those of entertainment and illustrative information.

ITS USES FOR PURPOSES OF ADVERTISEMENT.

These are obvious, were such deemed desirable. We can conceive, moreover, its potential application—as distinct from existing practice in picture transmission—to public telegraphic and telephonic services to the transmission of lists of prices, or of facsimile signatures or documents, and to its use by the police and the forces of the Crown, or as an aid to navigation.

TELEVISION OPERATING AUTHORITY.

Holding the view which we do of the close relationship which must exist between sound and television broadcasting, we cannot do otherwise than conclude that the Authority which is responsible for the former—at present the B.B.C.—should also be entrusted with the latter. We therefore recommend accordingly, and we have received an assurance that the Corporation is prepared fully to accept this additional responsibility and to enter whole-heartedly into the development of television in conformity with the best interests of the licence-paying public. In discharging this task the accumulated experience of the Corporation as regards sound broadcasting cannot fail to prove of great value. Presumably a separate licence will be required from the Postmaster General specifically authorising the Corporation to undertake the broadcasting of television.

We have, of course, considered the possible alternative of letting private enterprise nurture the infant service until it is seen whether it grows sufficiently lusty to deserve adoption by a public authority. This would involve the granting of licences for the transmission of sound and vision to several different firms who are pioneering in this experimental field. We should regret this course, not only because it would involve a departure from the principle of having only a single authority broadcasting a public sound service on the air, and because the subsequent process of "adoption" (which we believe would be inevitable) would be rendered costly owing to the growth of vested interests, but also because we foresee serious practical difficulties as regards the grant of licences to the existing pioneers as well as possibly to a constant succession of fresh applicants. It is, therefore, our considered conclusion that the conduct of a broadcast television service should from the outset be entrusted to a single organisation, and we are satisfied that it would be in the public interest that the responsibility should be laid on the B.B.C.

ADVISORY COMMITTEE.

Whilst we think that the B.B.C. should exercise control of the actual operation of the television service to the same extent and subject to the same broad principles as in the case of sound broadcasting, we recommend that the initiation and early development of this service should be plan-

ned and guided by an Advisory Committee appointed by the Postmaster General, on which the Post Office, the Department of Scientific and Industrial Research and the B.B.C. should be represented, together with such other members as may be considered desirable. We recommend that this Committee should be appointed forthwith, for a period of, say, five years.

The Committee should advise on the following:—

(a) The performance specification for the two sets of apparatus mentioned, later including acceptance tests, and the selection of the location of the first transmitting station.

(b) The number of stations to be built subsequently, and the choice of districts in which they should be located.

(c) The minimum number of programme hours to be transmitted from each station.

(d) The establishment of the essential technical data governing all television transmissions, such as the number of lines per picture, the number of pictures transmitted per second, and the nature of the synchronising signals.

(e) The potentialities of new systems.

(f) Proposals by the B.B.C. with regard to the exact site of each station, and the general lines on which the stations should be designed.

(g) All patent difficulties of a serious nature arising from the operation of the service in relation to both transmission and reception.

(h) Any problem in connexion with the television service which may from time to time be referred to it by His Majesty's Government or the B.B.C.

Normally the Committee would not concern itself with detailed financial allocations, or with business negotiations between suppliers of apparatus and the B.B.C. It is further considered that the Committee should not deal with the compilation of programmes, the detailed construction of stations, or their day-to-day operation, unless specifically invited to do so.

It will be clear from the foregoing that the Committee would be composed of both technical and non-technical members, and it is anticipated that a part of the Committee's work would best be carried out by a technical sub-committee.

Such experimental work as may be necessary for the establishment of stations and the operation of the service would be carried out by the B.B.C. in the usual course of its functions, but this would not, of course, preclude the enlistment of the co-operation of Government Departments or other organisations in technical researches.

USE OF ULTRA-SHORT WAVES FOR TELEVISION AND THEIR EFFECTIVE RANGE.

As previously mentioned, the transmission of high definition television is practicable only with ultra-short waves, and a wide band of frequencies is necessary. Fortunately, there should be no difficulty, at present at all events, in assigning suitable wavelengths in the spectrum—between 3 and 10 metres—for public television in this country, although in allocating such wave-

lengths regard must, of course, be paid to the claims of other services. The recent experimental work has been conducted upon wavelengths around 7 metres.

Technically, it is desirable that the transmitting stations should be situated at elevated points, and that the masts should be as high as practicable, consistent with any restrictions which may be deemed necessary by the Government. The mast at present in use in Berlin is about 430 feet high, and the question of employing masts of greater height is under discussion in Germany. Quality of reception varies, of course, with the location of the receiving station and the nature of its surroundings. It may be observed that reception of these ultra-short waves does not seem to be materially affected by atmospherics. The most frequent sources of interference appear at present to arise from some types of electro-therapeutic apparatus, and from the ignition systems of motor cars; but we understand that it is possible to prevent or reduce certain types of such interference by simple remedial devices.

Present experience both here and abroad seems to indicate that these ultra-short waves cannot be relied upon to be effective for a broadcast service much beyond what is commonly called "optical range." Generally speaking, it is at present assumed that the area capable of being effectively covered by ultra-short wave stations of about 10 kilowatts capacity will not exceed a radius of approximately 25 miles over moderately undulating country. In more hilly districts this may be considerably reduced, and indeed in certain areas an entirely reliable service may be impracticable. It is clear, therefore, that unless and until the effective range be increased, a large number of transmitting stations would be required to provide a service covering most of the country, though we think that with 10 stations, probably at least 50 per cent. of the population could be covered from suitable locations.

PROVISION OF TELEVISION SERVICE

We nevertheless envisage the ultimate establishment of a general television service in this country, and in this connection we contemplate the possibility of television broadcasts being relayed by land line or by wireless from one or more transmitting stations to sub-stations in different parts of the country. We should observe that recent developments in cable technique render it possible for the first time to transmit, over considerable distances, frequencies such as are required for high definition television.

While the establishment of such a service should be, in our opinion, the aim, we do not feel that we can advise you to proceed at once to approve the construction, at great expense, of a network of stations, intended to cover most of the country. The total number of stations required for such a purpose is as yet unknown to anyone; and the total cost is accordingly purely speculative. Moreover, television will be a constantly developing art, and new discoveries and improvements will certainly involve continued modifications of methods—at least during its early years. A general service will only be reached step by step; but the steps should be as frequent as possible and in our opinion the first step should be taken now.

CHOICE OF SYSTEM AND PATENT DIFFICULTIES.

We have been furnished with a great deal of information—much of it of a confidential character—concerning various systems of television. Continuous progress is being made in the art; and even during the few months of our investigations, research has brought a number of new and important discoveries.

The task of choosing a television system or a public service in this country is one of great difficulty. The system of transmission governs in a varying degree the type of set required for reception; and it is obviously desirable to guard against any monopolistic control of the manufacture of receiving sets.

At the same time it is clear from the evidence put before us that those inventors and concerns, who have in the past devoted so much time and money to research and experiment in the development of television, are looking—quite fairly—to recoup themselves and to gather the fruits of their labours by deriving revenue from the sale of receiving apparatus to the public, whether in sets or in parts, and whether by way of royalties paid by the manufacturers or by manufacturing themselves. It is right that this should be so, and that the growth of a new and important branch of industry, capable of providing employment for a large number of workers, should in every way be fostered and encouraged to develop freely and fully.

The ideal solution, if it were feasible, would be that, as a preliminary to the establishment of a public service, a Patent Pool should be formed into which all television patents should be placed, the operating authority being free to select from this Pool whatever patents it desired to use for transmission, and manufacturers being free to use any of the patents required for receiving sets on payment of a reasonable royalty to the Pool.

START OF SERVICE.

We have come to the conclusion that a start could best be made with a service of high definition television by the establishment of such a

SERVICE IN LONDON.

It seems probable that the London area can be covered by one transmitting station and that two systems of television can be operated from that station. On this assumption we suggest that a start be made in such a manner as to provide an extended trial of two systems, under strictly comparable conditions, by installing them side by side at a station in London where they should be used alternately—and not simultaneously—for a public service.

There are two systems of high definition television—owned by Baird Television Limited and Marconi-E.M.I. Television Company Limited respectively—which are in a relatively advanced stage of development, and have indeed been operated experimentally over wireless channels for some time past with satisfactory results. We recommend that the Baird Company be given an opportunity to supply the necessary apparatus for the operation of

its system at the London station, and that the Marconi-E.M.I. Company be given a similar opportunity in respect of apparatus for the operation of its system also at that station. . . . Transmissions from both sets of apparatus should be capable of reception by the same type of receiver without complicated or expensive adjustment. The definition should not be inferior to a standard of 240 lines and 25 pictures per second.

PROGRAMMES.

It is scarcely within our province to make detailed recommendations on the subject of television programmes. To what extent those programmes should consist of direct transmissions of studio or outdoor scenes, or televised reproductions of films, must be determined largely by experience, technical progress and public support, as well as by financial considerations. No doubt the televising of sporting and other public events will have a wide appeal, and will add considerably to the attractiveness of the service. We regard such transmissions as a desirable part of a public television service, and it is essential that the B.B.C. should have complete freedom for the televising of such scenes, with appropriate sound accompaniment, at any time of the day.

With regard to the duration of television programmes, we do not consider that it will be necessary at the outset to provide programmes for many hours a day. An hour's transmission in the morning or afternoon which will give facilities for trade demonstrations and, say, two hours in the evening, will probably suffice. As regards the future, the B.B.C. and the Advisory Committee will doubtless be guided by experience and by financial considerations.

FINANCE.

We estimate that the cost of providing the London station, including all running and maintenance expenses, programme costs and amortization charges (calculated on the basis of a comparatively rapid obsolescence), for the period up to 31st December, 1936, will be £180,000.

We have carefully considered the question of providing the necessary funds. Roughly speaking, the means suggested to us for so doing may be classified under two heads:—

- (a) Selling time for advertisements, and
- (b) Licence revenue.

Advertisements may take two forms: they may be either (i) direct advertisements for which time is bought by the advertiser such as, for instance, a dress show by Messrs. Blank; or (ii) the acceptance, as a gift, of programmes provided by an advertiser and coupled with the intimation of his name, in accordance with a standard formula, such as, for instance, "This programme comes to you through the generosity of Messrs. Dot & Dash," the latter system being usually known as that of "sponsored programmes." As regards direct advertisements, this proposal has been frequently examined in past years. In relation to sound broadcasting it was discussed and rejected by the Sykes Committee on Broadcasting in 1923. We do not differ from that Committee's view and

accordingly do not recommend this course. As regards "sponsored programmes," for which the Broadcasting authority neither makes nor receives payment, the Sykes Committee saw no objection to their admission; and they are now specifically allowed under the B.B.C.'s Licence, although the Corporation has, in fact, only admitted them on rare occasions. We see no reason why the provision concerning sponsored programmes in the existing Licence should not be applied also to the television service; and we think it would be legitimate, especially during the experimental period of the service, were the Corporation to take advantage of the permission to accept such programmes.

In attempting to provide funds from licence revenue there appear to be four possible courses:—

- (1) The raising of the fee for the general broadcast listener's licence.
- (2) The issue of a special television listener's licence.
- (3) The imposition of a licence upon retailers.
- (4) The retention of the existing listener's licence at 10s. and the contribution from that licence revenue of the necessary funds during the experimental period.

We are left with the conclusion that, during the first experimental period at least, the cost must be borne by the revenue from the existing 10s. licence fee. . . . We suggest that the best course would be for a reasonable share of the amount to be borne by each of the two parties—the Corporation and the Treasury.

The existing programmes represent amazingly good value for one-third of a penny per day and the general body of listeners may not unreasonably be asked to help, at no extra cost to themselves, in a national experiment which, if successful, will ultimately enhance programme values for a large part of their members. We feel that the development of British Television, in addition to being of evident importance from the point of view of science and entertainment, and of potential importance from the angles of national defence, commerce and communications, will also directly assist British industries.

WIRELESS EXCHANGES (RADIO RELAYS.)

We have considered the question, which has been raised in evidence, of the relaying of public television broadcast programmes by Wireless Exchanges. We see no reason why such a practice, if technically feasible, should not be allowed under the same conditions as are applicable in the case of sound broadcast programmes.

PRIVATE EXPERIMENTS AND RESEARCH.

We hope that encouragement will continue to be given to all useful forms of experiment and research in television by firms or private persons. It is true that much experimental work can be done by transmission from one room to another by wire without recourse to a radio link. In certain cases, however, the use of such a link is necessary; and we trust that . . . adequate facilities for experimental work will continue to be given.

RECENT TELEVISION DEVELOPMENTS

A RECORD OF PATENTS AND PROGRESS Specially Compiled for this Journal

Multiple Scanning Elements :: A New Kerr Cell :: Mozaic Transmitting Screen
A Special Mirror Drum :: Method of Transmitting Films

Mechanical Scanning Systems (Patent No. 418,759.)

One of the usual pair of rotating drums is formed with two or more sets of mirrors, which rotate at the same speed but are canted at a dif-

ferent angle to the axis, so that one set of mirrors throws one scanning-line across the screen, whilst the second set forms another scanning-line close to the first, and so on.

As shown in the figure, the image of an illuminated aperture A is focused on the screen S, via a lens L, a drum D, comprising 30 mirrors and rotating at a speed of 3,000 revs. per minute, and a second drum D₁. The latter, which is built up of three sets of 19 mirrors, rotates at a lower speed than the drum D. Owing to the different angular setting of the three sets of mirrors M, M₁, M₂, each throws a separate but adjacent scanning-line across the screen S.

The drums D and D₁ are geared so that D makes a complete revolution during the time taken for one horizontal "line" of mirrors on D₁ to change to the next line. The result

is that the number of scanning-lines is trebled.—(J. L. Baird and Baird Television, Ltd.)

Kerr Cells (Patent No. 419,072.)

A number of gold or silver plated plates, of the shape shown at A, are

about 52 pictures (measuring 19 mm. by 24 mm.) can be produced in two seconds, but the subsequent developing, fixing, etc., occupies at least 10 seconds and the overall length of film required is both inconvenient and expensive. On the other hand it is not feasible to use a 16 mm. film, since the ribbon is too easily damaged; also the relatively-wide spacing of the perforation or track-holes makes it diffi-

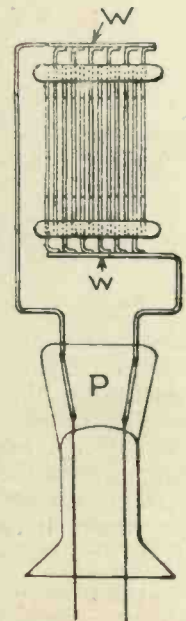

Patent No. 419,072.

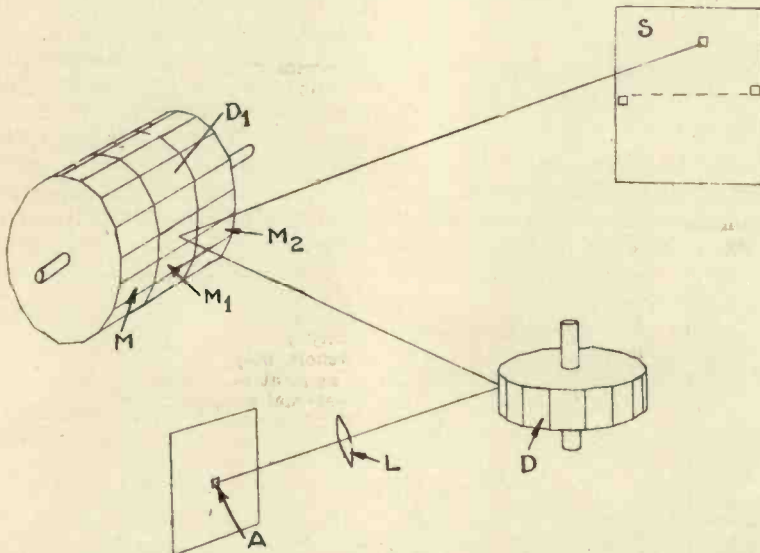

A scanning system employing three or more scanning members. Patent No. 418,759.

assembled together with intermediate "spacers" in a screw jig J, and the terminal tags are clamped together by running molten glass so as to form beads B, B₁. The plates are then taken out of the jig and the projecting tags are welded at the top and bottom to a wire support W. This is mounted in turn on the pinch P of a glass bulb, which is then filled with nitrobenzine.—(Marconi's Wireless Telegraph Co., Ltd., and E. G. Herriott.)

Films for Television (Patent No. 419,419.)

In so-called "film" television systems, where the scene to be televised is first recorded on a cinematograph film, which is then rapidly developed and subjected to the scanning apparatus, practical difficulties arise in connection with the size of the film. Using the normal film 35mm. wide,

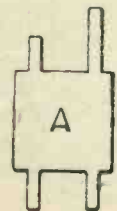
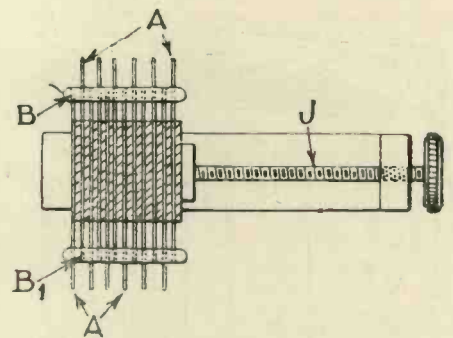

A new construction of Kerr cell. Patent No. 419,072.

cult to secure a sufficiently uniform drive.

These difficulties are overcome, according to the invention, by using a standard 35 mm. film and recording two pictures, one above the other in

the transparent window W of a cathode-ray tube on to a photo-electric electrode P, consisting of a "mosaic" of insulated light-sensitive cells. These are formed by first oxidising an aluminium

paths R to a ring electrode E, will vary in accordance with the light-and-shade values of the picture. The corresponding fluctuations in voltage across a resistance R are amplified by the valve V and used to modulate the outgoing carrier wave.—(*Electric and Musical Industries, Ltd.*, and J. D. McGee.)

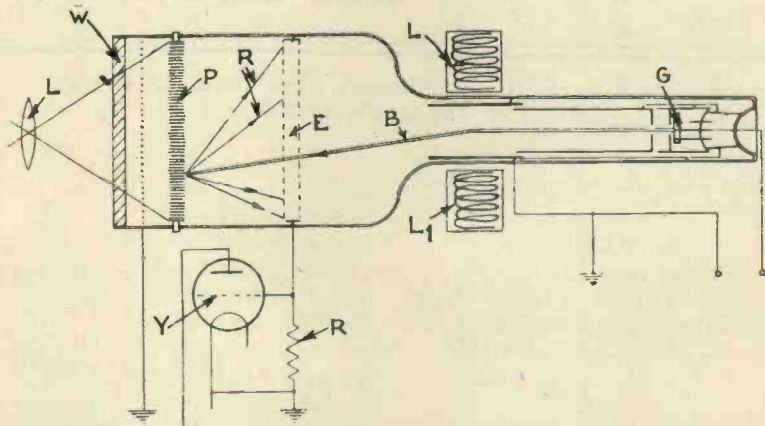

A method of transmitting images wherein the object to be transmitted is formed on a multiplicity of photo-electric elements. Patent No. 419,452.

a longitudinal direction, in the space usually occupied by one. This reduces the length of film required by one-half; simplifies the fixing and developing operations; and, in particular, prevents the emulsifying material from running into the tracking-holes, where it is liable to clog the drive of the film.—(*Fernseh Akt.*)

Cathode-Ray Transmitters

(Patent No. 419,452.)

The picture to be televised is focused by a lens L, through

wire and then coating it with a thin film of silver. The wire is next cut up into suitable lengths, which are packed together to form a sur-

Scanning Drums

(Patent No. 419,523.)

A series of mirror strips M, say 90 in all, are screwed at one end into a number of tongues T cut out of a flange F, forming part of the mirror drum D. The strips are first of all set at the correct tangential angle about the axis of the fixing screws S, and the lower end of each is then fastened by a screw S1 which passes, with clearance, through the strip-holder, and engages the lower part of the drum. By tightening up this screw, each strip can be given a slight bend or tilting movement as required. This is made possible by the natural flexibility of the tongues T cut out of flange F.—(*Electric and Musical Industries, Ltd.*, and C. O. Browne.)

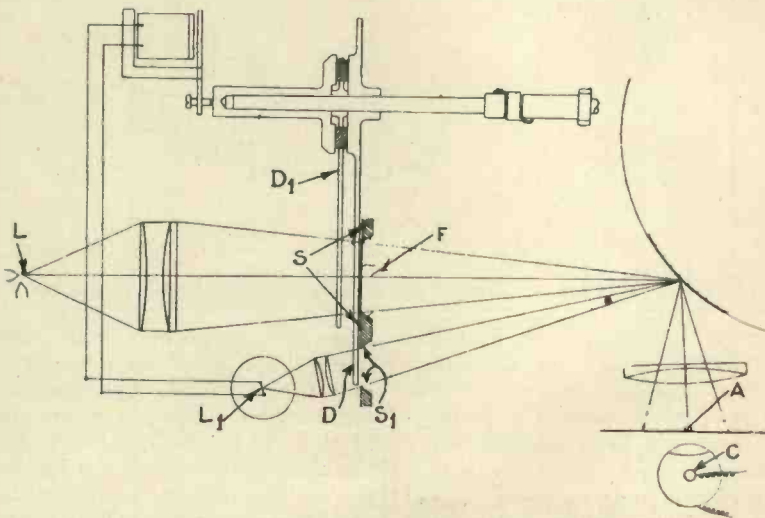

Method of transmitting films. Patent No. 419,811.

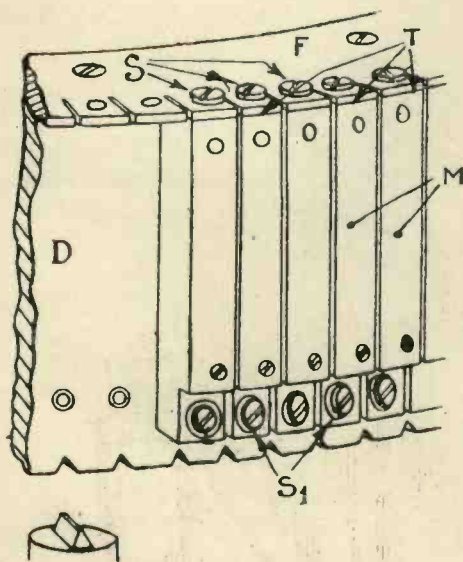

A special construction of mirror drum. Patent No. 419,523.

face containing roughly 10,000 photo-electric elements to the square inch.

The opposite face of the mosaic electrode or screen P, is now scanned by the electron beam from the "gun" G of the tube, under the control of the deflecting coils L, L1. Owing to the emission of electrons produced by the image of the picture projected on the forward face of the screen, the intensity of the gun or scanning ray, as it is reflected back along the

Film Television

(Patent No. 419,811.)

The film F is moved continuously in front of a slit S, illuminated by a lamp L. The resulting beam of light is scanned by a mirror-drum M and swept over an aperture in a screen protecting the photo-electric cell C. The light from a second lamp L1 passes through a lower slit S1, a portion of which is periodically blocked by a rotating shutter D,

(Continued on page 112.)

BRITISH COMMERCIAL TELEVISION PROGRESS

THE SCOPHONY FILM TRANSMITTER

Here are the very latest details of the new Scophony Film Television Transmitter. It is for high definition work and will prove useful when television broadcasts commence. The use of film will overcome the difficulties of obtaining material for the broadcasts.

“TELEVISION” has already had the opportunity of referring in its December issue to new developments in the Scophony laboratories on the manufacture of high-definition film television transmitters. We are now in a position to publish exclusive technical details of these transmitters, as communicated to us by Scophony, Ltd.

The following is the general description of the Scophony 120-line film television transmitter, as recently supplied to a company in this country:

The optical system consists, on the illumination side of the film, of a scanning wheel, which is totally-enclosed to prevent dust accumulations on the lens surfaces. The scanning wheel, together with its accompanying optical system focuses a small intense spot of light on the film. On the other side of the film is a condenser system of lenses which concentrates light transmitted by the film on to an unchanged area of the cathode of the photo-electric cell, ensuring uniformity of photo-electric response.

The light source is a small exciter lamp, requiring 32 watts.

This consists of a cinema head adapted for continuous traverse of the film past the gate and is driven by a synchronous motor a speed of 25 frames per sec. The scan-

ning wheel is mounted direct on the shaft of a synchronous motor. All motors and mechanical parts are balanced and are vibrationless. In the body of the stand is fitted a rectifier unit for the supply of low-voltage D.C. to the filaments of the scanning and sound pick-up exciter lamps.

These consist of a pre-amplifier in a carefully constructed, sound-proof, shielded box and includes a high sensitivity photo-electric cell, mounted opposite a small window in the box. The amplifier is operated entirely from the mains and includes special devices to maintain constancy of potentials. A second amplifier, mains operated, follows the pre-amplifier. Signals are amplified up to 100 volts r.m.s.

The outfit is capable of continuous service over long periods, for instance with film loops for experimental purposes, and there is no need for special ventilation or excessive precautions against fire, as powerful arc lamps are not used.

The 180-line film transmitter has similar specification with slightly different optical system.

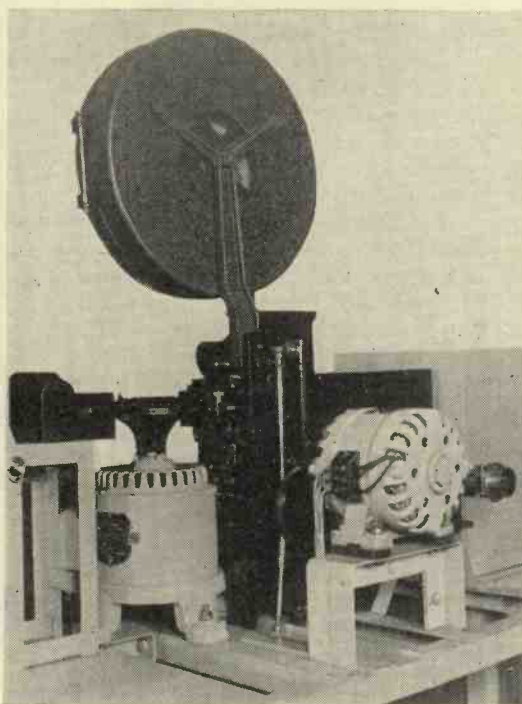

A close-up view of the high-speed scanner, light source container and film drive motor.

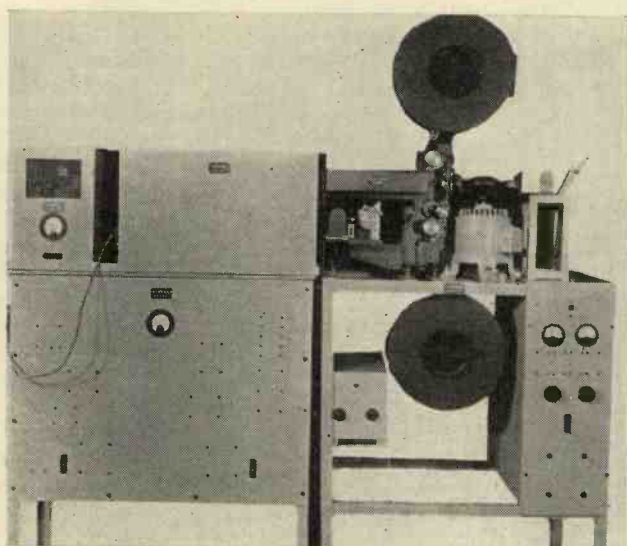

View of projector lead and high-speed scanner. Panel on the right contains the rectified and smoothed supply to the sound and television light sources. On the left is the amplifier gear. Bottom panel contains mains eliminator gear for amplifiers.

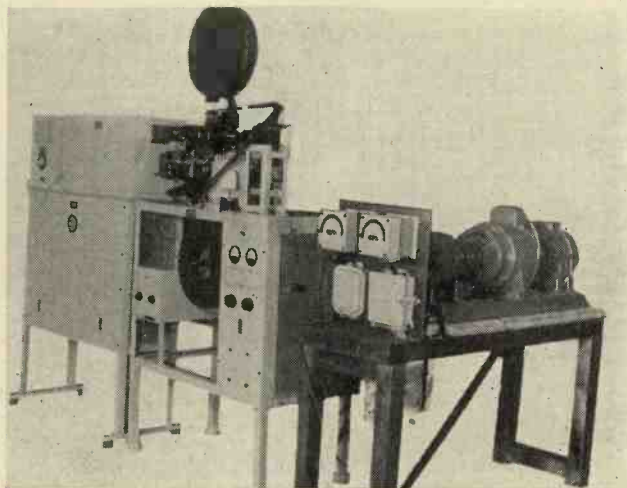

View showing on the right frequency changer, centre unit the film projector, scanner and mains rectified light source supply. Extreme left, amplifier equipment, all mains operated.

THE TELEVISION ENGINEER

AN EXPERIMENTAL HIGH-DEFINITION TELEVISION RECEIVER

By R. S. Holmes, W. L. Carlson and W. A. Tolson.

The following article is an abstract from the Proceedings of the Institute of Radio Engineers and describes an experimental receiving system for the Iconoscope transmissions. The receiver includes sound, picture and synchronising.

THE system comprised alternating the sound and picture carriers throughout the television band, with each sound carrier adjacent to its accompanying picture carrier and spaced a fixed frequency away. A television channel then consists of a picture carrier and modulation plus an accompanying sound carrier and modulation. One complete television channel was provided, with the picture transmitter operating at 49 megacycles and the sound transmitter operating at 50 megacycles.

The receiver had a single radio-frequency tuning system which con-

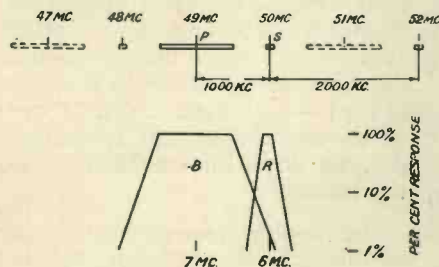

Fig. 1.—Channel arrangement and receiver selectivity characteristic.

sisted of two coupled radio-frequency circuits having sufficient band width to accept both carriers and their side bands simultaneously, and a heterodyne oscillator which beat with the two carriers to produce two intermediate frequencies one megacycle apart. The radio-frequency system tuned over the proposed television band of 40 to 80 megacycles. Two first detector tubes supplied the resulting intermediate frequencies to two separate intermediate amplifiers, which were tuned to 6 and 7 megacycles for the sound and picture signals respectively.

Since the sound intermediate amplifier was relatively sharp, it furnished a sharp reference for tuning the receiver, and assured that when the sound was tuned in, the picture signal was also properly tuned.

The system of carrier spacing and the resulting receiver operation can be seen by reference to Fig. 1. In the upper part of the figure is shown the television channel with the sound carrier *S*, and its side bands and the picture carrier *P*, with its side bands. The probable location of the adjacent channel stations is also illustrated. In the lower part of the figure are shown the characteristics of the double intermediate amplifiers of the receiver, the sound intermediate selectivity characteristic *A* being relatively sharp, as it is required to pass only a relatively narrow band of frequencies, and the picture intermediate selectivity characteristic *B* being broad to pass a wide band of frequencies. The high-frequency transmissions indicated by the scale in the upper part of the figure have been converted into intermediate frequencies when referred to the receiver characteristics indicated by the companion scale in the lower part of the figure, but the channel frequency separation remains unchanged.

When the receiver is tuned in the normal manner so that the sound carrier *S* in terms of its intermediate frequency is properly tuned with respect to curve *A*, then the corresponding picture intermediate frequency is also correctly tuned in the centre of curve *B*.

A guard band was provided between the edge of the picture selectivity curve and the accompanying sound carrier, and also an additional guard band to the proposed adjacent sound channel on the other side.

The Aerial

In the majority of locations where receivers were tested, an inside aerial approximately a half wavelength long was found to be satisfactory. Directive aerials were used in some instances, and, as was expected, gave a better signal than non-directive.

The aerial was coupled to the first tuned circuit in the receiver by a small coupling capacitor. This method of coupling gave slightly better results than magnetic coupling between 40 and 80 megacycles, the frequency range of the receiver. The radio-frequency and oscillator system are shown in Fig. 2. From the aerial coupling capacitor, the signal was impressed on the high side of the first

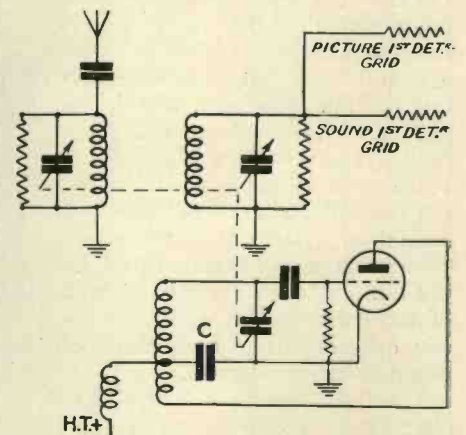

Fig. 2.—Radio frequency and oscillator system.

radio-frequency circuit. This circuit was coupled by a combination of capacitive, inductive, and conductive coupling to the second tuned circuit to which were connected the grids of the two first detector valves in parallel. The coupling and loading of the radio-frequency circuits were adjusted so that the band width of the combination was substantially 1.5 megacycles over the tuning range of 40 to 80 megacycles. The gain from the aerial to the grids of the first detectors remained substantially constant over this band.

An RCA-56 valve was found to be satisfactory over the range when used in the oscillator circuit of Fig. 2. At the high-frequency end of the range the circuit of the oscillator was essentially a straight feed-back circuit, on account of the high imped-

ance of the tuning condenser compared to that of the padding capacitor C . As the capacity of the tuning condenser was increased, lowering the frequency, the ratio of these impedances decreased, thus effectively increasing the feed-back in the oscillator and maintain-

three intermediate-frequency stages tuned to 6 megacycles, having an over-all gain from first to second detector grids of approximately 10,000 with a band width of 130 kilocycles at

cutting occurred in the intermediate-frequency system. Therefore, conditions were ideal for providing excellent high fidelity sound reception. Following the screen-grid second de-

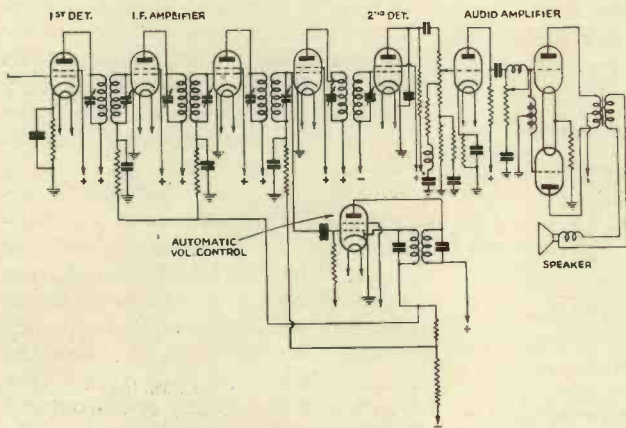

Fig. 3.—Theoretical circuit of the sound receiver.

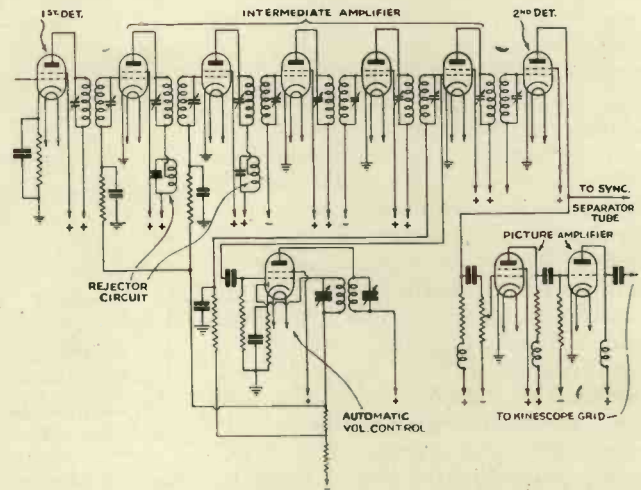

Fig. 4.—Theoretical circuit of the picture receiver.

ing a substantially uniform oscillation. The padding capacitor C also performed the usual function of properly aligning the oscillator and radio-frequency circuits over the 40- to 80-megacycle band. The oscillator operated at a higher frequency than the incoming carriers and heterodyned them to 6 and 7 megacycles. A combination of capacitive, inductive, and conductive coupling between the oscillator and first detector circuit maintained a substantially uniform oscillator voltage on the first detector grids. The oscillator and the

90 per cent. of the peak amplitude. It was sufficiently wide to allow for oscillator drift and permit easy tuning of the receiver. Extensive filtering was provided in the supply leads to the intermediate-frequency stages to prevent regeneration. An automatic volume control stage was incorporated in parallel with the last intermediate-frequency stage and controlled the bias on all three intermediate-frequency valves, with full control on the first two and partial control on the last one.

With the wide spacing between car-

rector was a tone-compensated volume control. An audio amplifier with a band-pass tone control supplied the audio signal to push-pull in the output stage.

Picture Channel

The schematic circuit of the picture channel is shown in Fig. 4. The picture intermediate-frequency amplifier consisted of five stages tuned to

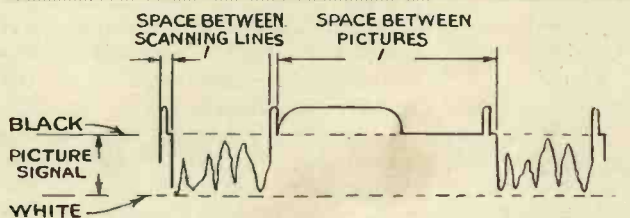
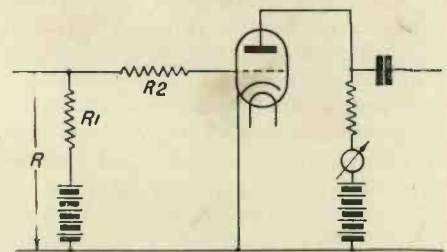

Fig. 5 (left).—Graph showing the composite signal received.

Fig. 6 (right).—Circuit for removal of picture component from composite signal.



two radio-frequency circuits were all tuned by the variable gang condenser.

Sound Channel

A schematic diagram of the sound channel is shown in Fig. 3. The sound intermediate-frequency amplifier consisted of a first detector and

riers chosen for these tests, there was no serious problem of cross-talk from the side bands of the picture transmitter such as is encountered in wide band broadcast receivers. The proposed spacing between adjacent television channels should also prevent any interference from this source. With the intermediate-frequency band width of 130 kilocycles, no side band

7 megacycles, having an over-all gain of approximately 10,000 and a band width of 1,200 kilocycles at 90 per cent. of maximum amplitude. (This figure also shows the sound intermediate-frequency characteristic.) The number of intermediate-frequency stages chosen for the picture intermediate amplifier was determined by the intermediate-frequency gain

and band width required, and was not determined on the basis of required selectivity. The six band-pass transformers in the amplifier did not of themselves furnish sufficient selectivity to prevent cross-talk from the sound signals into the picture channel. In order to increase the attenuation, rejector circuits tuned to the sound frequency were coupled to the second and third picture intermediate transformers. The net attenuation at 6 megacycles compared to 7 megacycles was about 50, which, combined with the cut-off of the picture amplifier, effectively eliminated any interference on the picture due to the sound signal. The wide band-pass characteristic in the picture intermediate-frequency stages was obtained by winding the transformers with resistance wire and adjusting the coupling between the primary and secondary windings to give a flat-topped response. Extensive filtering was provided in the supply leads to prevent any possible regeneration due to common coupling through the supply circuits.

An automatic volume control stage in parallel with the last intermediate-frequency stage controlled the bias on the first two and last intermediate-frequency valves.

Following the second detector, the picture signal was applied to the picture amplifier and to the synchronising separating circuit. The output of the picture amplifier was applied to the grid of the kinescope.

Synchronisation

In order to reproduce the picture represented by the received signals, it is necessary that the scanning point on the mosaic of the iconoscope and the scanning point on the kinescope be maintained in synchronism. A random variation of synchronisation at the receiver, corresponding to the linear equivalent of one picture element, will result in a loss of 50 per cent. of the normal resolving power. This made it imperative that the synchronising signals be separated in such a manner that integration would not seriously distort the wave fronts of the synchronising signals.

If it is assumed that such distortion shall be less than one-half picture element, the variation in timing of adjacent synchronising signals, due to integration of picture or extraneous signals, must be less than

0.5 microsecond for horizontal synchronising signals and 800 microseconds for vertical synchronising signals, approximately. It was found that with the signal-separating methods employed in these receivers, such a condition was obtainable under normal operating conditions.

Fig. 5 shows a section of the received signal voltage wave taken over a period of time equivalent to that of four scanning lines. The section is

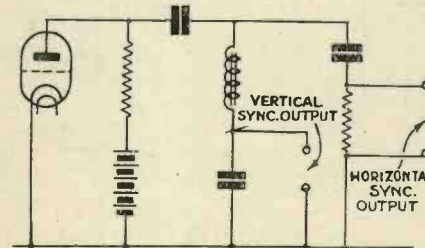

Fig. 7.—Circuit for separation of vertical and horizontal synchronising signals.

taken at the bottom of the picture in order to include the vertical synchronising impulse. It should be noted that the horizontal synchronising impulses are superimposed upon the "black" signal between scanning lines, and the vertical impulse is superimposed upon the "black" signal between pictures. The fact that

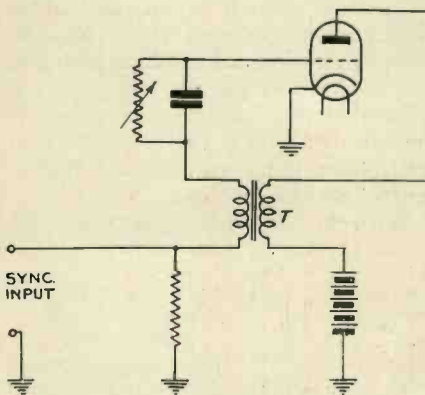

Fig. 8.—Circuit of blocking oscillator.

the picture signal cannot go beyond the "black" amplitude assures that the picture signals will not interfere with the synchronising action. The circuit and operating characteristics of the arrangement used for removing the picture component from the incoming signal are shown in Fig. 6. Referring to Fig. 6, it should be noted that the bias battery potential is such as to make the grid of the valve positive with respect to its

cathode. The positive potential of the grid is limited by the presence of R_2 in series with this circuit. R_2 is made very large with respect to the grid-cathode resistance for positive values of grid potentials. Thus, for all values of positive potential applied at A , substantially all the voltage appears across R_2 rather than across the grid-cathode circuit. For all values of negative potential at A in excess of the positive bias potential, the grid is negative with respect to its cathode, and the resistance is very high compared with R_2 ; thus the effect of the series resistance is negligible.

Due to the wide divergence between the time constants of the horizontal and vertical synchronising signals, either may be removed from the composite synchronising signal by means of very simple frequency selective circuits. Fig. 7 shows the circuit utilised for separating the horizontal and vertical synchronising signals and confining them to their respective channels.

Deflecting Circuits

General.—The oscillator used for producing a voltage of saw-tooth wave form must, in general, meet three fairly definite requirements. It must produce an output having a sharply peaked wave form. For horizontal deflection the ratio of the duration of the peak to the time for a complete cycle should not be greater than 1:15. For vertical deflection this ratio should not be greater than 1:80. As an alternative to this requirement, the oscillator may produce an output having a wave front sufficiently steep so that impulses having the required characteristic can be secured through the use of high-pass circuits.

The third requirement for a deflection oscillator is that the drift of the free-oscillating frequency shall be small. The reason for this requirement is that it minimises the difficulties encountered in synchronisation. An oscillator known as a blocking oscillator was chosen as most satisfactorily meeting all the above requirements.

The blocking oscillator is similar in circuit to, but having constants differing from, a conventional inductively coupled sine wave oscillator. A typical circuit is shown in Fig. 8. The

coupling, damping, grid condenser, and grid leak are so proportioned that the grid current drawn during the positive portion of the grid voltage wave is sufficient to build up a negative voltage across the grid condenser greater than the value required for plate current cut-off.

Vertical Deflecting Circuit

The choice between the use of magnetic and static fields for deflection

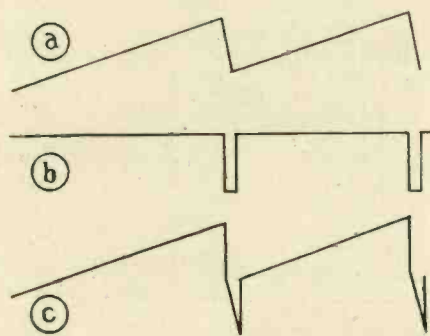

Fig. 9.—Wave shape required to force a saw tooth current wave through resistive and inductive circuits

of the cathode ray beam in the vertical direction is made relatively simple by virtue of the fact that the fundamental frequency is very low (24 per second), thus presenting a minimum of difficulty in passing a current of saw-tooth wave form through a com-

ponents for static deflection are not reduced by the low operating frequency. For static deflection, the impedance and phase-shift requirements considerably complicate the design of a suitable output transformer and make necessary the use of a low impedance output valve. A consideration of the foregoing indicated the use of magnetic deflection in the vertical direction as being best suited to the purposes of the tests to be made.

[Fig. 9 shows the voltage wave shape required to produce a saw-tooth wave form of current through a pure resistance, a pure inductance, and a circuit containing both resistance and inductance. Such a required voltage wave may be produced in a very simple circuit, as shown by Fig. 10. Condenser C is charged in series with resistor r at a substantially constant rate through resistor R . The periodic positive impulses from the blocking oscillator are applied to the grid circuit of the discharge valve, the plate circuit of which is connected across the charging source and resistor R . The discharge valve thus periodically discharges C by a definite amount. The voltage wave across C is saw-tooth in shape, while that across r is a pure impulse. It is evident that by properly proportioning C and r , it is possible to produce a voltage wave shape having the required amount of

for the application of a magnetic deflecting field to a cathode-ray tube is influenced by several considerations. Assuming that a linear saw-tooth wave form of flux is produced normal to the axis of the cathode-ray beam, a linear saw-tooth deflection of the beam will result only if the flux field is of constant density throughout the range of movement of the beam. A second effect of non-uniform flux distribution is defocusing due to the finite size of the beam at the point of deflection. It is obvious that a non-uniform distribution of flux will produce deflection of the electrons by an amount depending upon the flux density at each point

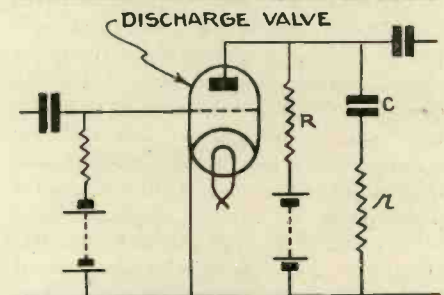

Fig. 10.—Circuit for producing a composite wave having saw tooth and impulse components.

in the cross section of the beam, thus resulting in a partial destruction of the focus on the fluorescent screen. Components of the deflecting flux which act along the path of the beam in a direction parallel to the motion of the electrons also produce defocusing, since such components constitute a focusing field varying in accordance with the instantaneous density of the deflecting field. Such considerations imposed limitations on the design of the magnetic deflecting structure and resulted in the adoption of a form which differs markedly from one based entirely upon considerations of magnetic efficiency alone. The magnetic yoke employed in the receiver is shown by Fig. 11.

Horizontal Deflecting Circuit

The choice between magnetic and static fields for horizontal (5,760 cycles) deflection is somewhat more involved than in the case of vertical deflection. In the case of magnetic deflection, the voltage across the deflecting coils involved in producing a saw-tooth current wave increases directly as the scanning frequency. For frequencies of the order of 6,000 cycles the required voltage peaks are

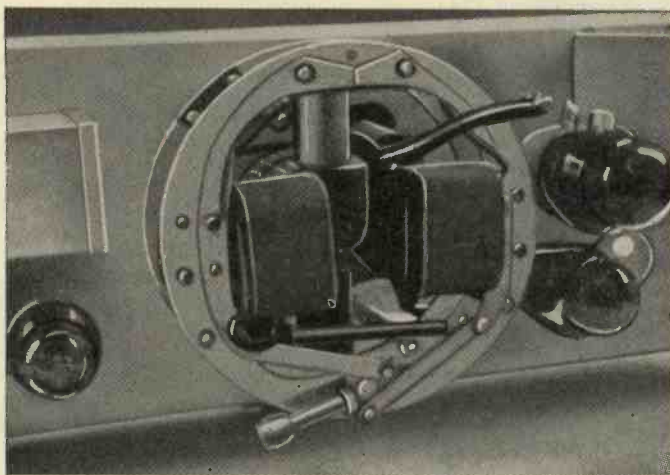

Fig. 11.—Photograph of magnetic deflecting yoke.

paratively large inductance. The fact that a highly inductive deflecting coil may be employed permits the use of a low voltage, low current output valve, whereas the voltage require-

saw-tooth and impulse components to force a saw-tooth of current through any given combination of output valve and deflecting coils.]

The design of a suitable structure

so high as to be destructive unless the circuit design is such as to minimize the voltage requirements. The voltage may be reduced by reducing the inductance of the deflecting coils, with a corresponding increase in the current requirements. The current limits are set by the output valve used.

A secondary problem is presented by the interaction between the fluxes in the vertical and horizontal deflecting yokes. The most serious results of such interaction are distortion of the scanning field and defocusing of the scanning spot. In the case of static deflection, the voltage requirements are not affected by the scanning frequency, but the required frequency band to be passed by the output transformer increases directly as the scanning frequency. From an economic standpoint there are factors favouring either system, but from the standpoint of sharpness of focus and minimum distortion of the scanning pattern, better results were obtained with static deflection in the horizontal direction. The design of the output transformer for application of deflection potential to the static deflecting plates is limited by several considerations. Chief among these are the alternating-current potential required across the deflecting plates of the kinescope, the voltage available on the plate of the output valve, and the required frequency vs. response and frequency vs. phase characteristics.

The oscillator and discharge valve circuits were diagrammatically the same for the horizontal and vertical deflecting circuits. The circuit constants were, of course, proportioned to the widely different frequencies at which they operated. The complete deflecting arrangement is shown schematically by Fig. 12.

The exact position of the scanning pattern on the end of the kinescope is affected to a minor extent by the mechanical line-up of the electron gun, by a permanent magnetisation of deflecting structures or other magnetic materials near by, and by the magnetic field of the earth. In order to ensure the exact location of the scanning pattern in the viewing aperture, means were provided for adjusting the position of the scanning pattern in both the vertical and horizontal directions.

For centring in the vertical plane a bridge arrangement was used where-

by a small amount of direct current could be passed through the vertical deflecting coils in either direction. For centring in the horizontal plane

carriers spaced one megacycle apart and the double intermediate amplifier in the receiver, only a single tuning receiver. The major controls located on the front of the cabinet were tuning, sound volume, sound tone, picture brightness, and picture contrast. These were the controls it might be necessary to adjust when tuning from one station to another. Another group of controls which required less frequent adjustment were arranged under the lid of the cabinet. These were focus, deflecting oscillator frequency controls, and scanning pattern size and centring. Screwdriver adjustments were provided inside the receiver for scanning pattern distribution and kinescope screen-grid voltage. These adjustments needed to be changed only when the receiver was set up for operation.

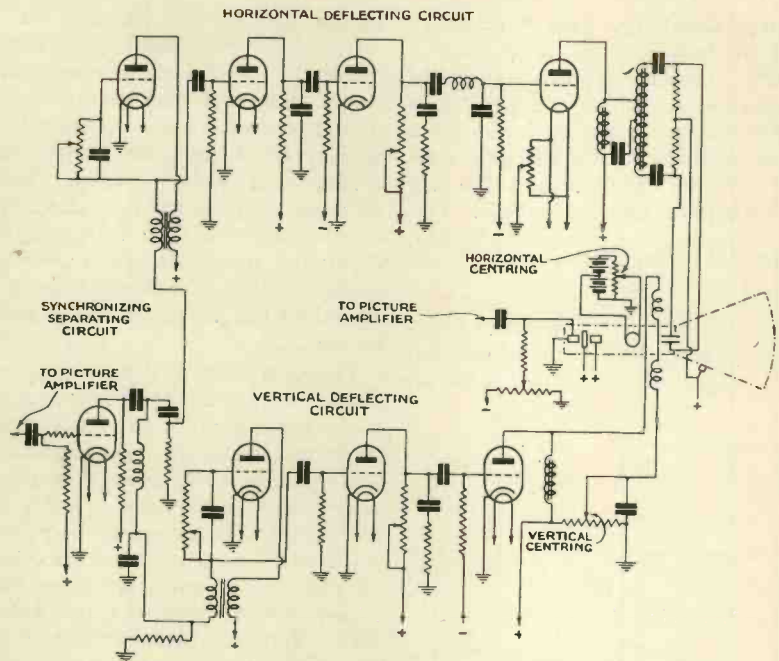

Fig. 12.—Schematic circuit of kinescope deflecting circuit.

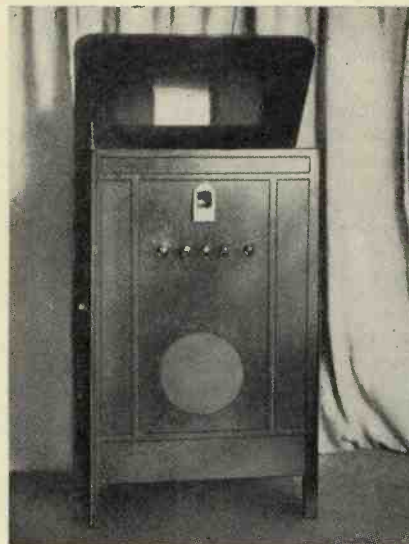

Fig. 13.—Photograph of complete receiver.

an arrangement similar to that employed for vertical centring was used, except that it was entirely independent of the horizontal deflecting circuit. Both arrangements are shown in Fig. 12.

On account of the system used for transmission of sound and picture on

General Arrangement of the Receiver

The general arrangement of the receiver is shown in Figs. 13 and 14. The parts were assembled on three units. All the radio-frequency and intermediate-frequency circuits and the picture and audio amplifier were

(Continued on page 106.)



Correspondence

Correspondence is invited. The Editor does not necessarily agree with views expressed by readers which are published on this page.

A Strange Phenomenon :: An Image Seen off the Screen Television with Batteries

A Strange Phenomenon

SIR,

I am very interested in the phenomena reported by your correspondent Mr. A. Parsons, F.T.S., in the December issue of TELEVISION. Although I know absolutely nothing about the apparatus used, thanks to the lucidity and preciseness of your correspondent, I presume to make these comments, which I trust will be very much to the point. For clarity I number them.

1.—I would suggest that Mr. Parsons communicate the same to Mr. Harry Price, the well-known psychic investigator, for I am convinced that the phenomena are outside the realm of physical science.

2.—Though duly noting that the image was "rather distorted," I should be vastly obliged if he could indicate briefly how and in what way the image was distorted. Was it blurred, inverted, negative, elongated, broadened, expanded along one diagonal, or merely utterly unrecognisable?

3.—Is it conceivable that, if the apparatus used chanced to have a lens for producing the image, that this lens might possibly have been accidentally focused on a point two feet from the screen and formed an image on a collection of dust particles?

4.—With reference to his remark that he had difficulty in reproducing it, I would remind him that psychic phenomena are notoriously difficult to reproduce, in fact it was this that prompted suggestion 1.

5.—Question:—Can one, or even two, television sets have a focus? Surely Mr. Parsons means that their beams met at this "point" (i.e., quite large area)?

6.—Stationary waves could only have been produced if he were using one common line source for both the receivers (unless he had two such sources with all their atoms vibrating in exact synchronism) and even if

they were produced there is no reason to suppose that they would be even slightly visible, and in any case they would be of no interest whatever, as they would occur at distances of half a wavelength of light apart, and would consequently be not only rather small but the greatest difficulty would be experienced in distinguishing one from its neighbour.

7.—If he seriously thinks the image was thrown on the pupil of his eye his scanning apparatus must have been truly extraordinary, being able to scan the pupil with thirty fine lines. If he means the retina was being used as a screen the beam would have had great difficulty in getting through the pupil, and the image would have been inverted.

8.—There is no evidence whatever why a shower of cosmic rays should happen to fall exactly two feet in front of your correspondent's screen at the precise moment he was making his experiments, or that it would reflect light if it did.

Finally, I must apologise to Mr. Parsons for being so purely destructive in my criticism, but if he had only provided us with a more concrete and less fanciful account of his phenomena I should have been able to be more helpful.

G.L.R. (Cambridge).

* * *

Image Seen off the Screen

SIR,

With regard to the phenomenon described by Mr. Albert Parsons in the December number, it is impossible to form a definite opinion without more knowledge of details, but in using optical apparatus the presence of "ghost" images, due to unwanted reflections at the backs or inner surfaces of lenses, etc., is not uncommon. To quote from "Optical Measuring Instruments," by Dr. L. C. Martin, of the Imperial College of Science (p. 219), "Stray light is one of the most serious bugbears of the optical designer. Every pair of

glass surfaces sends forward with the main beam a certain proportion of light which may form independent and surprisingly bright images in unexpected places."

As pointed out by several correspondents, the apparition may also be explained by persistence of retinal impression, the very phenomenon which makes television possible.

A. EVERETT, M.A., F.T.S.
(Sunbury-on-Thames).

* * *

Television with Batteries

SIR,

I have been a reader of your interesting and valuable journal since 1927, and still have the first number of TELEVISION. Some years ago, Mr. Dinsdale gave a lecture and practical exhibition at Workington, I was a very interested member of the audience and was instantly taken up with this new branch of wireless. Like most other amateur constructors, I find the financial part the most difficult, but there is the added pleasure of knowing you have built it yourself. My apparatus consists of a Kolster Brandes battery set KB242 model for the vision and a small three-valve Philips mains set for the sound. For the KB set I use a Philips eliminator, 150 volts 30 mA output, also a set of double capacity Exide H.T. batteries at 120 volts. My television receiver is a disc machine and consists of such articles as Meccano parts, electric horn motor, gramophone governors, some bed iron for supports, a headlamp resistance and an old-fashioned bull's eye lens in conjunction with a Woolworth lens, I also use an ordinary neon lamp converted. After two or three cardboard discs I purchased a Mervyn disc. With this lot of junk I have received some very good pictures considering the distance from the transmitting station and the district in which I live. I think this is the only receiver in this district and I have had quite a number of visitors to see it and as many more eager to do so. They all say, it seems hardly possible. The picture signal comes in very strong and gives good detail, such as a string of beads, movement of the eyes, a violin bow, buttons on coats, etc.; each item can be distinguished easily. However, close-ups seem to be best. I think an artist singing comic or well-known songs and playing a pianoforte would make a good entertaining transmission. Some of the more classical

"Modern Physics and Television Research" :: The "No-Screen" Image :: The Kerr Cell

pieces seem slow and dull. It is a pity that some such station as the Scottish or North Regional could not be used as the Midland has a habit of fading very badly; also it is very difficult to receive in the north-west. On Saturday afternoons, it is hopeless, but on the Wednesday nights the programmes are generally good. At present I am constructing a mirror drum and hope thereby to obtain better pictures.

H.D. (Workington.)

* * *

"Modern Physics and Television Research"

SIR,

There is a slight misprint in Mr. J. C. Wilson's instructive article on Modern Physics in TELEVISION for January, 1935. On page 28, line 28, for $x' = m(-vt)$, read $x' = m(x-vt)$.

A.E. (Sunbury).

* * *

The "No-screen" Image

SIR,

Please let me take this opportunity of congratulating you on the very excellent standard of your Journal.

I wish to thank your many correspondents for their interesting comments upon my no-screen image experience. I can hardly discuss to the length I should like in the narrow space of your correspondence columns but will put forward one or two comments in the light of your correspondents' questions and remarks. Re A.G.F. (Portsmouth). For experiments in the principles of television I was using the straight disc sets. No covers were used and I had two disc sets displaced at about 60° so that I may see both screens at will.

Now, however queer it may seem, I was trying to see if it were possible to form a picture on the disc spokes themselves. I wondered whether a stroboscopic effect could be brought about whereby a picture (however crude) would stand still when synchronism was effected. However (and this is important), I had not so far looked into the screen and was holding the speed controls of the two visors with left and right hands when after a few minutes I became aware of an image of a dancer (crude as it was) about two feet away. This point may have been the focal point of the two visors. I immediately looked into the right-hand screen and

there was a dancer! Foolishly enough I stopped the disc and tried other angles without result.

With regard to R.P.C. (London, N.W.) the image was right side up. His suppositions appear to be good and further tests along these lines should be worth while. I was very glad to hear that L.H.B. (London, S.W.) had been trying to effect screenless vision. Personally I feel that such a feature should be possible, especially if experiments with the focusing of rays could be followed up. The light source was the Baird neon-plate type.

G.C. (Worthing) will have noted from the first two paragraphs that the "mid-air" image was the first indication I had that a picture was framed. All of us will have noted that a picture can be framed by listening to the sound of the whole apparatus. The air in the room was clear, no one was smoking and lights were out. Both visors were producing images, in fact it was when synchronism occurred between the two that the phenomenon happened.

Now if this image were due to the meeting of the two sets of lines at the two-foot point I think it likely that rays were thrown off the *inside cross-section of the disc holes*. I do not think the image structures were ejected from the tunnels or lenses. Both receivers were producing positive images.

Personally I wish all those of us who are interested in this new aspect of television could meet and have a detailed discussion on the subject and decide how best to experiment with screenless vision. Let me say, in conclusion, that I am a strong advocate of large screen television and look forward to all cinemas and homes having a good screen television system, but having had, by pure accident, the experience quoted must, as need be, look into the problem, for is this not how pioneers of the past have blazed the trail?

ALBERT PARSONS, F.R.A., F.T.S.
(Radio Section, Municipal College, Portsmouth).

"Television"
will keep you abreast of the
times.

The Kerr Cell

SIR,

In connection with my notes on Dr. John Kerr, which have appeared elsewhere in this issue, I have received the following interesting comments from Dr. Gray, of Glasgow:—

There are a few things I should like to say about the pronunciation of the word "Kerr," but I, and you, recognise that *our* vowel sounds are different. Let me mention the main points. In Scotland, not England, the word is sounded in three ways:—

- (1) "Care," as in "day" (Scot.). This is the Doric pronunciation.
- (2) "Kerr," as in "service." This is the recognised pronunciation. Incidentally, it is the sound "meh," made by Scottish lambs!
- (3) "Carr," as in "car," or in "baa," the sound of English lambs! This sound gives the Scottish attempt at giving the English way of trying the second sound above. The Kerrs originated in Ayrshire, and those who, not strong enough for the Scottish climate, emigrated to England, had to call themselves Carr, even although they retained the spelling Kerr. Dr. Kerr belonged to the original Ayrshire stock, and probably was born a "care" (1) and died a "kerr" (2)!

The only relevant comment that I would like to make is that we could never hope to reproduce the pleasant sounding trilled "r" which Dr. Gray brings into his pronunciation of "Kerr," and so it would seem that we must content ourselves by calling him "Cur"!

G. PARR (London, W.).

* * *

"The Parson's Phenomenon"

SIR,

From Mr. Albert Parsons' letter in the December issue it is not clear whether he is seriously experimenting, accidentally receiving or trying to imagine the result he *obtained*.

I am sure Mr. Parsons meant his letter to be taken seriously, this has been accorded him by other of your readers. May I ask through your columns that he will now give more details of the *two* television sets he had working when he *managed* to

Day v. Night Reception :: Displaced Scanning :: Short-wave Interest

get a rather distorted image of a dancer off the screen some two feet away.

In the meantime I am making another brown paper disc and raking over the "kid's" Meccano box.

B. LUFF (Watford).

Day v. Night Reception

SIR,

I wish to say that I can receive the television transmissions on Saturdays now perfectly as most of the time the signal is clear and steady, I am using a 2 H.F. set, and a disc scanner, and reception is remarkably clear. The night transmissions are never good owing to fading and background noise.

F.H. (Bournemouth).

Displaced Scanning

SIR,

Re "T.S.R.'s" comment on my proposed method of scanning to assist synchronising. The writer has, apparently, not fully grasped the idea propounded, so I have endeavoured to clarify it by two sketches enclosed.

Sketch A shows the approximate representation of a person in dark clothing on a light background and occupying a width equal to 10 lines.

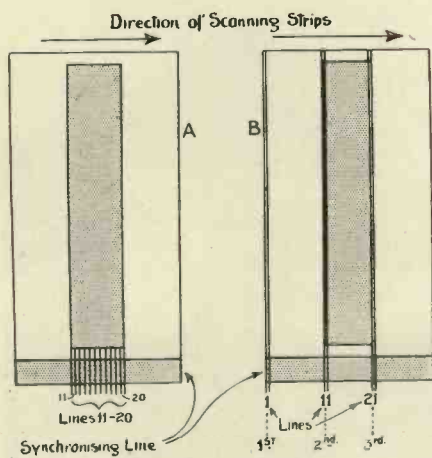

This figure, scanned 1, 2, 3, etc., would render 10 consecutive teeth on the synchroniser inoperative.

When scanned as in B only 1 tooth in 3 receives no impulse and the 20 remaining fully peaked impulses are distributed round the wheel.

Scanning the picture, as shown in B, 1, 11, 21, etc., the same benefit will apply, seeing that the widely spaced scanning strips do not follow the moving image in its path, as would be the case in A.

G. E. CARDEN (Folkestone).

P.S.—My original letter should have read:

1, 11, 21—2, 12, 22 and not
1, 10, 20—2, 11, 21.

Mr. J. Le Lievre, of Milston, St. Martins, Guernsey, will be glad to get into touch with another reader interested in television in the island.

Short-wave
Correspondence

Short-Wave Interest

SIR,

I am very glad to hear that you are publishing a journal devoted to short waves, etc., as such a journal is badly needed, particularly one that contains up-to-date reception reports and also interesting and instructive articles for the constructor and experimenter.

There is no doubt at all that short waves and television will be the coming vogue. Short-wave reception offers so much of interest, and from the four corners of the earth one never knows exactly what one is going to pick up.

These combine to make short-wave radio a hobby of unrivalled interest, both on the listening and the technical sides, with its constant joy of construction and experimenting.

R. D. EVERARD.

* * *

SIR,

In the January issue of the "T. and R. Bulletin," there appears an account of TELEVISION AND SHORT-WAVE WORLD.

This is a long felt want among the ever-increasing number of short-wave listeners, and it is gratifying to see that at last a regular short-wave issue is being published for the needs of the amateur radio fan.

In *Amateur Wireless*, "News of the Amateurs," by A. K. Jowers, is greatly appreciated and is eagerly de-

voured which, although always small, covers a very interesting field. Now is the chance for every amateur and short-wave fan to write A. K. Jowers, who is to be in charge of the short-wave section of this journal, and see that enough space is to be reserved and guaranteed in every issue.

Technical articles are wanted, circuits for the experimenters to try, lay-outs for short-wavers, aerial and earth systems, and last but not least, a complete and up to date account of how the "Hams are coming in," which gives readers a regular and reliable list of calls heard. This enables them to compare their own logs and provides them with valuable and comparative information.

In concluding, I only hope that this letter will be accepted as an honest appeal for bigger and guaranteed short-wave articles and news.

JACK WILSON (Sec.,
Wishaw and District Radio Society).

Sound Film in a Television
Test

A sixty-line television system utilising a thirty-watt automobile headlight lamp, aided by a novel spherical lens to increase the illuminating efficiency of the bulb twenty times, was publicly demonstrated recently in New York by William H. Peck. An ordinary sound-film newsreel was used as the picture source.

The images were relayed directly over a lead-covered cable from the transmitting apparatus to the receiver about ten feet away.

The picture as it appeared on a screen in a semi-darkened room was about a foot square. Included in the transmitting equipment is a new type of light valve, said to be smaller than heretofore employed.—*New York Times*.

A description of the Peck transmitter and receiver appears on another page of this issue.

The two short-wave transmitters reserved for television are now carry-out experimental broadcasts at the following times: G.M.T. 08.00-11.00 daily except Fridays and Sundays. G.M.T. 19.30-21.00, Tuesdays and Thursdays. Sound on 6.985 metres; vision on 6.67 metres.

THE PHYSICAL SOCIETY EXHIBITION AND TELEVISION

THERE was but little apparatus which was directly connected with television at this year's exhibition of the Physical and Optical Society. An interesting exhibit for

four photo-cells arranged round the sides of the aperture was led to a five-valve amplifier of conventional design, and thence by wires to the tube scanning system. The circuit used

is one which has been described in this journal previously (May, 1934) with minor improvements.

The image shown on the screen was clear-cut and free from the fuzziness sometimes seen in cathode-ray pictures. It was explained that this was due to the improved modulating properties of the high-vacuum cathode-ray tube used. The size of screen was approximately 7 ins. diameter, but in spite of the small scanning area the picture was clearly visible at a distance of several feet.

On another part of the stand a smaller tube was reproducing a 180-line screen, and the sharpness of focus was again apparent. The demonstration showed the facility with which the tube could be

adapted for high definition work, and in conjunction with the showing of the black-and-white screen a notable advance in television science has been achieved.

We are informed that the white screen will shortly be available for experimenters, but the standard high-vacuum tube with blue or green screens is now on the market at a list price of £8 8s. od.

Micro-wave Transmitter

By R. W. Corkling.

R. W. Corkling exhibited an interesting micro-wave transmitter. Radio waves shorter than one metre are difficult to produce by conventional methods, with any appreciable output. Micro-waves obtained by positive grid methods are generally very unstable. The transmitter about to be described was designed to produce very short waves with a reasonable output. Although positive grids are utilised, good outputs are obtainable, owing to the fact that instability is overcome.

The circuit consists of a double-lecher system, one tuning the anode, the other the cathode circuit. It is

(Continued on page 112.)

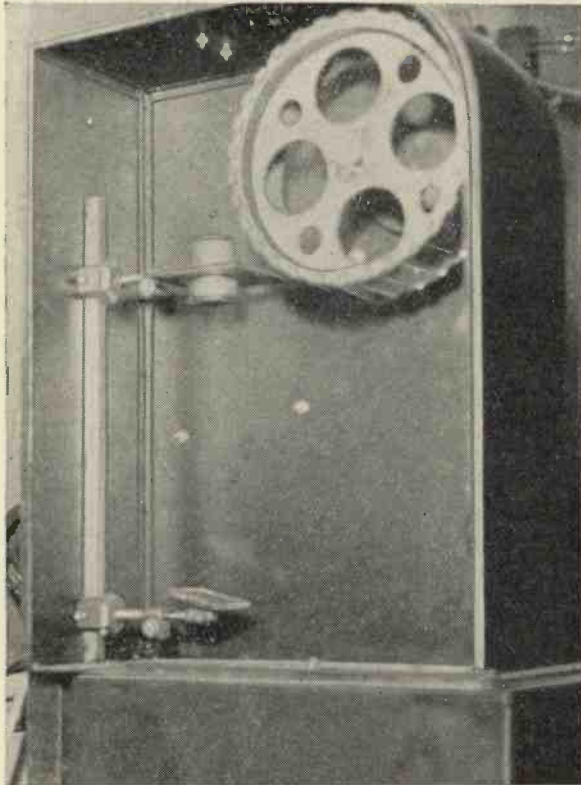

View of the scanning arrangement of the Edison projector. The light aperture is on the top left corner, and the reflecting mirror at the bottom. The light from the drum passes through a window cut in the base of the housing.

the television enthusiast was the Edison Swan Company's stand in the research section, where a black-and-white cathode-ray television picture was being shown for the first time.

A small 30-line experimental scanner was used to produce the signal and a picture of a girl's head was shown on the cathode-ray tube screen in astonishing detail. The interior of the scanning transmitter is shown in the photograph, while the arrangement of the mirror-drum and optical system can be seen.

The picture to be scanned was laid flat on the baseboard of the apparatus, the scanning system being mounted over it. The output from

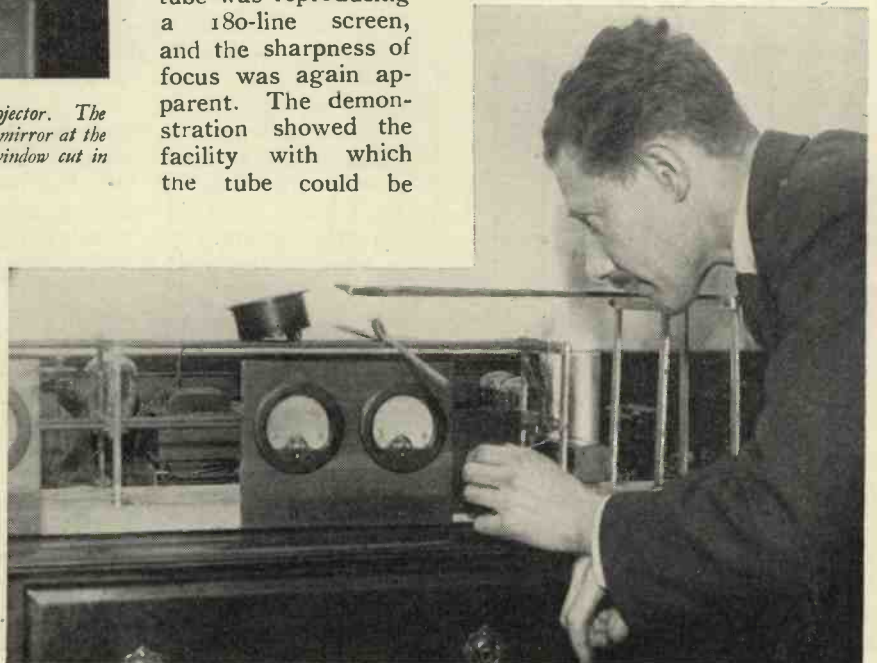

Mr. R. W. Corkling and his micro-wave transmitter.



REVIEWS OF THE PROGRAMMES AND RECEPTION REPORTS

THE problem of the "fading," discussed in the last issue, has been solved during the month in a most ingenious way and it is now possible to fade from a scene in the studio to a blank white screen and thence to a card in the caption machine. By the same device the producer can fade from caption to caption with a momentary pause between the cards while the blank screen is in position and can also fade from caption to studio in the same way.

I find looking less of a strain to the eyes since this improvement. While pictures used to merge into one another as cards in the caption machine were rotated, each picture is now stationary before it is scanned, a blank screen being seen while the scene is changed. And a steadier picture is not the only advantage of this advance; time is saved at rehearsal now that it is no longer necessary to judge to a split second the moment to switch from studio to drawing or caption in the small machine,

and rapid changes of scene in the main studio can also be made during what is best described as a "white out." It is a relief to me that the occasional blurring of pictures which marred some changes has disappeared.

Additional apparatus has made this refinement possible. A circular white card seven inches in diameter has been fixed to the centre of the black scanning disc, which revolves in front of the light source for the caption machine. Another lamp casts a spot of light near the circumference of this card, which revolves with the scanning disc. Thirty narrow black radial lines are spaced around the white disc and an additional photo-electric cell views the card as it revolves. By this means the cell delivers a current which is exactly the same as that derived from a plain screen.

* * *

I enjoyed the queer programme that was transmitted on January 2. I like a surprise; and a peep behind

the scenes is always intriguing. I have met one or two of the engineers who work in the control room and I was amused to see them doing their stuff. At the same time, I have every sympathy with lookers who were expecting the usual entertainment and were naturally disappointed in what they saw. The performance must have been embarrassing to those who had invited friends to look with them for the first time and one or two wrote to the B.B.C. to complain. The official programme gave no hint that the transmission would be unusual.

The programme opened normally with Max Templeton's shadowgraph, which provides interesting visual entertainment. Patter and a solo piano accompanied the silhouettes, but I missed the sound effects which we have had before with this act.

After about ten minutes—rather longer than is usually given to one subject—Eustace Robb appeared in my visor to introduce one of the television engineers, who started to talk on "the works." It was D. R. Campbell, who showed his own diagrams, which are used for checking the apparatus at high and low frequencies.

At this point lookers began to ring up. They were not getting the results described in their visors as the cards were demonstrated. This seems to me to vindicate the experiment and several sets are probably in better shape as a result of it.

Some enthusiasts were glad of this chance to check results in their receivers and asked for more broadcasts of the same kind, and one looker went so far as to demand the exhibition of a checking card between each act in every programme. For artistic reasons this would be a mistake; but I suggest that fifteen minutes might be given once a month to this kind of experiment for the benefit of



A corner of the Physical Society's Exhibition recently held at South Kensington. Our photograph shows the Marconi exhibits: Left to right: Cathode-ray oscillograph; single sideband and carrier broadcast equipment; portable diathermy equipment; selection of modern Marconi valves; double pen recorder; frequency measuring equipment.

new lookers and others who are making adjustments to their gear. We could spare the last quarter of an hour occasionally now that programmes are longer.

The producer, whose regular features make an excellent picture, then returned to the scanner and, walking with microphone in hand, took us behind the scenes for a glimpse of the control room with the men at work. Here the scanner was swivelled into reverse. Eustace Robb took his seat in the producer's chair and the microphone was passed from man to man as each described his work, the light illuminating his actions. It was interesting to see a hand turning a switch to bring in the caption and then to watch the effect of this action.

But the most informative part of the demonstration was to follow when D. R. Campbell appeared again in the studio to demonstrate the lighting effects. He showed us that one side

of his face was placed in shadow when the cells on that side were faded and then proceeded to demonstrate how a silhouette picture is transmitted. I was much wiser when that programme ended.

* * *

Sydney Jerome has often been heard, but never seen until one day this month the black curtain was lifted and his piano was pushed into the left-hand corner of the studio against the backcloth. He sat and played in the background while artists danced before the piano. In the light from the projector a pianist cannot read his music and a music lamp on the piano would spoil the picture, so Sydney had to memorise all the numbers. A close-up revealed a face full of character and a most engaging grin.

On the same evening Cal McCord was spinning a thick black rope, which appeared very clearly in my

visor, despite its speed. He can sing, too, this artist. I would recommend Victor Leopold as a tap dancer if a male should ever be needed to dance in the radio Music Hall programmes.

Mrs. Jerome plays the piano, too, and she made her debut in another programme when Charles Parker danced on gramophone records. I once sat on an album of discs which cost me two pounds to replace. Charles has a better technique, but in the end I rather wished that he would crack one, just to pep things up.

* * *

A new form of entry was discovered by Betty Bolton, who swung into the picture on a rope. She carried a mountaineer's pickaxe over her shoulder for her song, "I don't wanna climb a mountain." A chest of drawers appeared for her other number, "In my little bottom drawer," but modesty forbids a mention of the garments which she produced from it.

* * *

George Mozart, game old-timer, was in the same bill, which provided some cheerful broad entertainment.

* * *

Another type of looker will have gained as much pleasure from a programme which was more distinguished for its sound than for visual effect. The producer is lucky to be able to engage artists of the quality of Leila Megane, who sang operatic arias in her rich mezzo-soprano voice, while Cyril Smith played three pieces with which he was to delight an audience in Wigmore Hall three days later.

The Victorian programme provided some lively burlesque and altogether January was a month which catered to every taste.

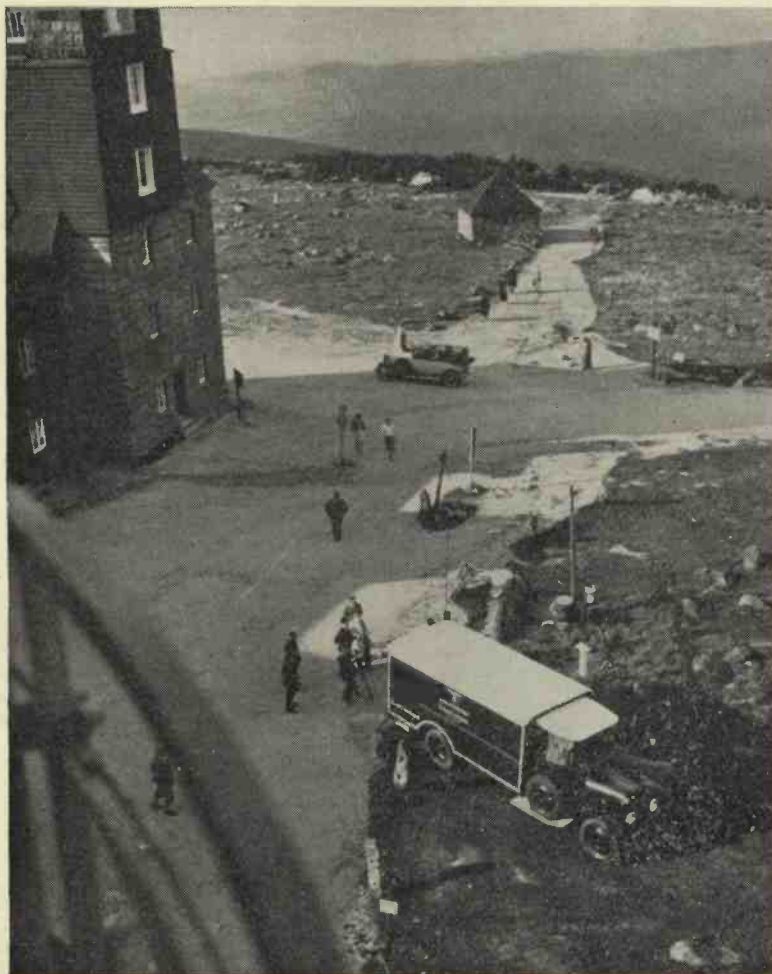

Television Experiments on the Brocken.

Television experiments are being conducted at present by the administration of German Posts and Telegraphs on the summit of the Brocken mountain in Central Germany. The picture shows the car in which the experiments are being conducted in front of the Brocken Hotel.

According to a statement from a German source the Russian authorities are organising four separate expeditions for the exploration of the Arctic Circle and in particular the lower reaches of the River Lena. Two special ships are being built at Archangel and will be equipped with powerful broadcasting transmitters. The Soviet radio officials propose to carry out television transmissions from the polar regions and to this purpose tests have been carried out by the Moscow RA1 Station on 7,690 metres. On this long wave the results have been very satisfactory.

MODERN HIGH-DEFINITION TELEVISION PRINCIPLES OF RECEPTION

By G. Baldwin Banks, B.Sc.
(Late of the Baird Laboratories)

In the preceding articles of this series the televising of films and scenes was described, and it was shown how synchronising impulses were superimposed on the resulting vision signal. This month it is proposed to describe general principles underlying the reception of high definition systems.

Ultra-short Waves

As previously stated, owing to the very wide band of frequencies—10 to 750,000 cycles—required by the 180-line television system, ultra-short wavelengths are used to radiate the vision signals. These very short electromagnetic waves are almost optical in character; they travel in very nearly straight lines being unable to follow the curvature of the earth's surface to any extent. For this reason, no matter what power may be used, the range of an ultra-short wave transmitter is limited and depends on the height of transmitting and receiving antennæ and the nature of the intervening ground.

Assuming the latter to be "flat," Fig. 1 shows how the curvature of the earth's surface limits the range of a short-wave broadcasting system. If r is the radius of the earth (approximately 4,000 miles), h and h' the heights of transmitting and receiving aeri-

figures given owing to the fact that these waves are not quite optical in character and do not have a sharply defined shadow. On the other hand, intervening high ground will reduce the ranges given and where the receiving aerial is in the shadow of a hill reception may be impossible.

Short-wave Antennæ

Although there are numerous forms of short-wave aeri-als, a half-wave aerial of the "dipole" type will probably be found the most satisfactory. Owing to the shadow effect previously discussed it is often found that a great increase in signal strength can be effected by elevating the dipole, especially in congested areas. In this case the antenna may be connected to the receiver by means of a transmission line. For this purpose ordinary twisted flex of low resistance will be found to be quite effective and may be connected to the receiver by means of a single-turn coupling coil.

Ultra-short Wave Receivers

For the reception of ultra-short wave transmissions the superheterodyne may be regarded as the most satisfactory receiver and is generally adopted. For television transmissions of the 180-line standard a very wide band-pass is required and the intermediate frequency is much higher than in normal superhets. Satisfactory results have been obtained with an I.F. of 8 megacycles.

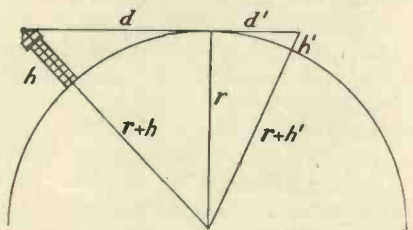

Fig. 1. Diagram showing how the curvature of the earth limits short-wave reception.

and d' the horizon distance of transmitter and receiver respectively. It will be seen that

$$d^2 + r^2 = (r + h)^2$$

$$d^2 = 2rh + h^2, \text{ neglecting } h^2 \text{ we have}$$

$$d = \sqrt{2rh}$$

$$= \sqrt{8,000h} \text{ miles.}$$

Similarly $d' = \sqrt{8,000h'}$ miles.

Taking the case of the Crystal Palace transmitter, which has an effective height of about 400 ft., it will be seen that this transmitter has a horizon of 25 miles. In other words signals on the ground will cease after 25 miles.

If the receiving antenna is elevated the range will be increased accordingly. Fig. 2 shows the relation between height of antenna and horizon distance. It will be seen that a receiving antenna 25 ft. high has a horizon of 6.2 miles and could receive the Crystal Palace transmissions up to a distance of $25 + 6.2 = 31.2$ miles, assuming level ground between the two stations.

Actually the range is somewhat in excess of the

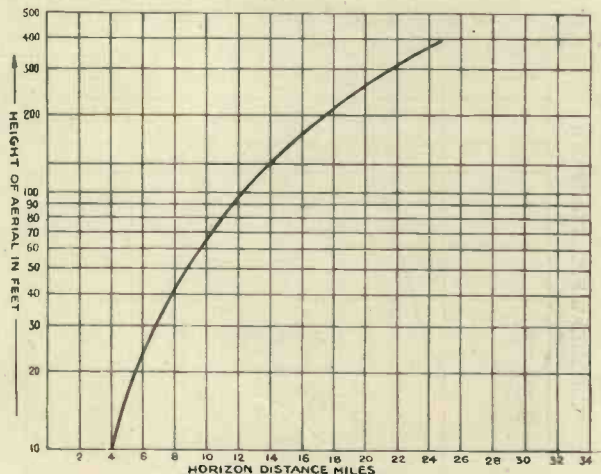

Fig. 2. Graph showing the relation between height of antenna and horizon distance.

SUPER-HETS FOR ULTRA-SHORT WAVE TELEVISION

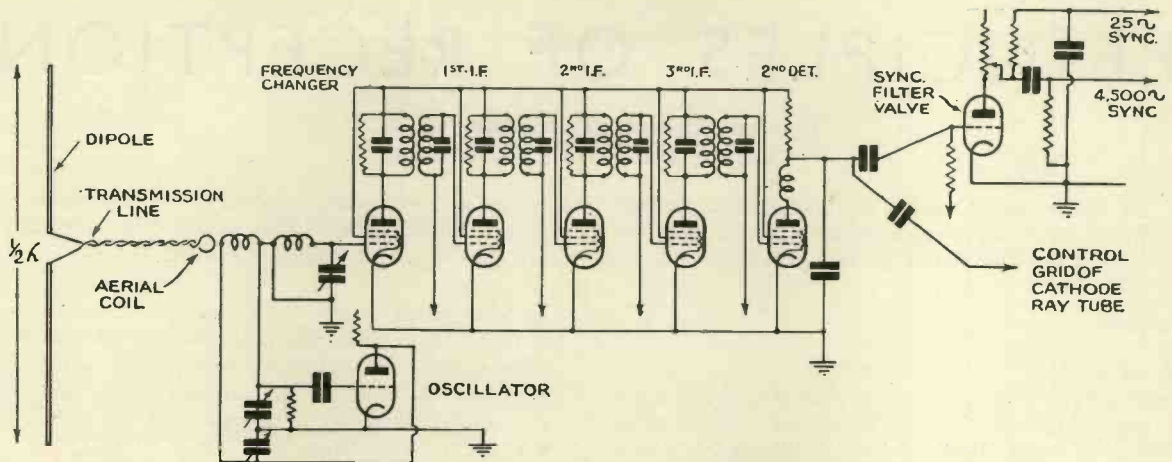

Fig. 3. A general circuit of a short-wave super-het for television.

Fig. 3 illustrates the general circuit principles. The radio-frequency coils are self-supporting and consist of a few turns of stiff copper wire. No formers are used in order to avoid dielectric losses. The frequency changer is usually followed by 3 I.F. stages, H.F. pentodes being very suitable in this part of the circuit. The I.F. transformers are designed so that adjustment of the micro-tuning condensers and the primary damping resistance enables a band-pass of from 7.25 to 8.75 megacycles to be obtained. Fig. 4 shows a typical response curve for the I.F. circuit. The second detector may be followed by one or more stages of L.F. amplification according to conditions, and it is usual to split the signal as shown. One branch supplies the signal to the control electrode of the cathode-ray tube and it will be noted that it is not necessary to remove the synchronising impulses as they serve to extinguish the electron beam during its return from the end of one scan to the beginning of the next.

The other branch applies the signals to a synchronising valve, the grid of which is negatively biased until the phase of the signals is non-conductive. The phase of the signals is arranged so that the synchronising impulses are positive, causing the valve to become conductive, the device acting as an amplitude filter. The filter in the anode

circuit serves to separate the 25- and 4,500-cycle synchronising impulses.

Scanning Circuits

Scanning circuits are so numerous and have been described so often in these pages that it will not be necessary to give a full description of any particular type. To produce the horizontal scan the electron beam is caused to move at a steady rate across the fluorescent screen of the cathode-ray tube. Having completed the scan the beam is rapidly returned to the commencement of the next scan. In order to carry out this operation a waveform of the "saw-tooth" type is required. The vertical traverse is carried out in a similar manner and the respective frequencies are 4,500 and 25 scanning cycles per second.

These saw-tooth waveforms are conveniently obtained by charging a condenser through a constant current device and rapidly discharging it through a valve or mercury relay such as the Thyatron. The first operation represents the scan and the second the return stroke of the scanning cycle. The scanning waveforms may be applied to the electron beam electro-

(Continued on page 109.)

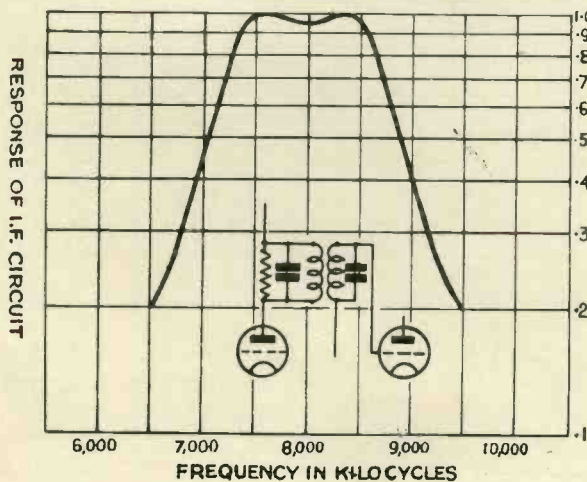
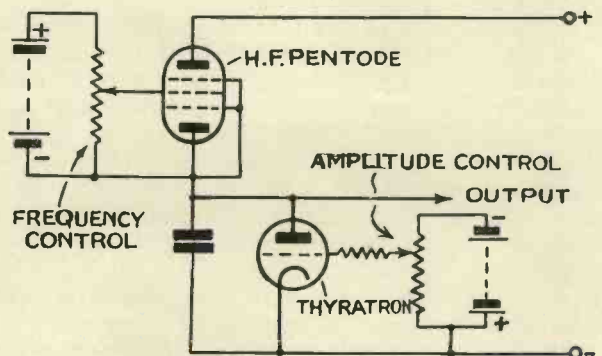

Fig. 4. (left). Graph showing response curve of the intermediate-frequency circuit.

Fig. 5 (below). A typical scanning circuit.



A "TRIGGERED" SYNCHRONISER

This article by J. H. Reyner, B.Sc., A.M.I.E.E., describes a practical scheme for using a mercury-vapour relay for synchronising. The advantages are that a more powerful impulse is available, and that no notice is taken of signals except at the end of each line.

SATISFACTORY synchronisation is, perhaps, one of the greatest problems in television. Even with the simplest mechanical systems difficulty is experienced in keeping the image steady, and one cannot give proper attention to obtaining the best detail when the image is "hunting" up and down, while nothing is more irritating than the sudden loss of synchronism which occurs all too often, causing the image to shoot rapidly through the frame.

The plain truth of the matter is that considerable power is required to hold a mechanical system in synchronism. I gave some figures for this in a recent article, and it is of interest to quote these again. The standard thirty-tooth wheel was used and the motor spindle was arranged so that the pole-pieces were one-third of the way between one tooth and the next, as shown in Fig. 1. A gradually increasing current was passed through the synchronising coils until the magnetic pull produced was sufficient to swing the armature round and pull the teeth into line.

figures were taken on free-running motors. If there is appreciable bearing or brush friction the power needed to move the armature round can be much more than this, and it is not unreasonable to assume that for satisfactory working a peak power of about ten watts is required.

Considering that the power to operate the neon or other source of light is usually under a watt, this synchronising power is disproportionately high. The peak power is twice the r.m.s. power. Moreover, since we are not concerned with the question of distortion, we can assume the power available to be about twice the normal rated output, but even this requires a valve having a rated output of 2½ watts. The normal A.C. output pentode will just about supply the power though rather better results are obtained with a triode of the PX4 class.

The method is truly of a "brute force" character. When one remembers that the power is only required for a small instant of time it

certainly seems that some better method could be devised, and I shall give details later in this article of a circuit which appears to overcome the difficulties very nicely.

Usual practice is to apply the ordinary signal to a suitable valve and to include the synchronising coils in the anode circuit. Current is flowing through the coils the whole time according to the variations in the modulation, and at the end of each scanning line the black band at the top of the picture

the synchronising impulse is limited in power to a value corresponding to the black parts of the image. It is no stronger than the impulse produced by a black band or sector anywhere in the picture, which leads to the second point, that, if there is a

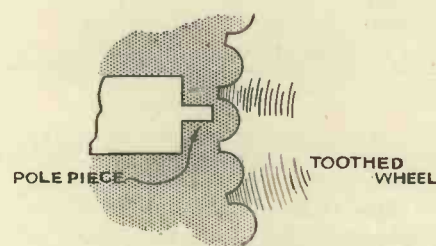

Fig. 1.—Relative positions of toothed wheel and pole piece during synchronising test.

black portion near the top of the image, the impulse produced may actually pull the motor out of step instead of synchronising it. This effect will have been noticed by most experimenters. It often happens as a figure moves towards the camera.

Timed Synchronising

There is a remedy for this, which is to use a timed synchroniser. If the synchronising pulses are controlled at the receiver so that they must occur at very nearly the correct moment, all we have to do is to trigger the mechanism at the exact instant by using the synchronising signal in the transmission. This sounds rather elaborate, but it can be done quite easily by using a time-base circuit such as is employed in cathode-ray reception.

Such a circuit is shown in Fig. 2. The high-tension voltage of about 180 to 200 volts is fed through a high resistance on to a condenser which charges up gradually. Across the condenser is a gas discharge tube and when the voltage on the condenser reaches a certain value the tube becomes conducting and a rush of current takes place discharging the condenser and starting the whole process over again.

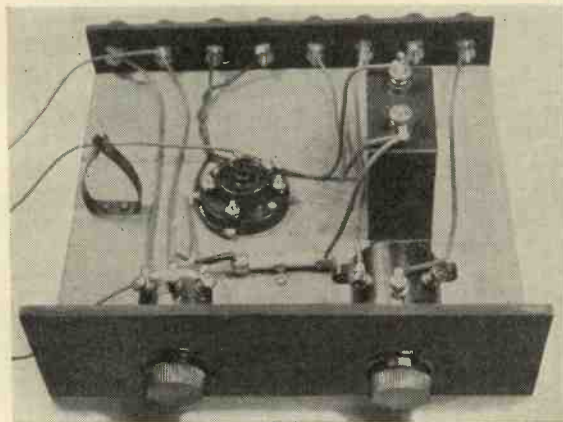

List of Parts.

- | | |
|------------------------------|----------------------------|
| 1 1 mfd. condenser. | 1 5,000-ohm potentiometer. |
| 1 0.1 mfd. condenser. | |
| 1 0.25 megohm potentiometer. | 1 2,00-ohm fixed resistor. |
| | 1 5-pin valveholder. |
| 1 15-volt grid bias battery | |

The synchroniser relay is quite easy to make up as this photograph shows.

The power required varied from 4½ to 6 watts, according to the motor, but it should be emphasised that these

produces a momentary heavy impulse which exerts the synchronising pull. Two points are worth noting. First,

The time taken for this cycle of events is controlled by the relative values of the charging resistance R and the condenser C and by the grid voltage on the gas discharge tube which determines the voltage at which the tube breaks down and becomes conducting. This latter point is important, because a very small change of the grid voltage will cause an appreciable variation in the breakdown voltage, causing the discharge

chronising pulse will only trigger the circuit if it occurs at the right moment. A similar impulse produced at any other time will not have the desired effect, because the condenser will not have been sufficiently charged up. The triggering action can only occur if the condenser is just on the point of discharging.

This arrangement is, of course, the standard time-base circuit and in itself is not new. L. H. Bedford has

to the condenser discharge. In Fig. 4 the coils are in series with the charging circuit. When the tube breaks down there is a sudden rush of current from the H.T. supply through the tube, which has now become conducting. This pulse is only momentary, but it is rather stronger than with the alternative arrangement.

With this circuit I was able to synchronise a disc machine rock steady

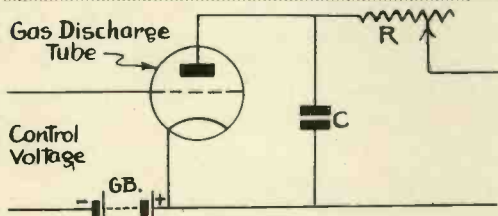

Fig. 2 (left).—A simple timing circuit.

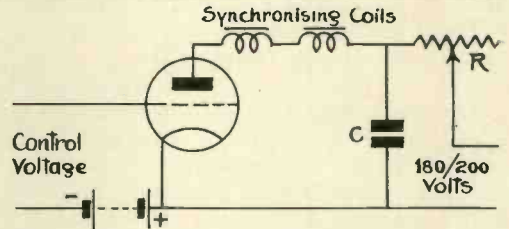

Fig. 3 (right).—Timed synchronising circuit.

to take place earlier or later than normal.

Triggering

Suppose that we arrange the circuit so that the discharges are taking place just a little too slowly, say, at between 360 and 365 per second instead of the correct figure of 375, but that we arrange to apply to the grid a small impulse at the correct instant every $1/375$ th of a second. The condenser will be charged nearly to the

suggested, however, that it can conveniently be applied to mechanical systems and I have made tests which show that it not only can be so used but is very successful. All that is necessary is to arrange that the current pulse when the condenser discharges passes through the synchronising coils. It is also necessary to arrange the constants of the circuit so that a large current pulse is obtained, which can be done by making the condenser large.

with a voltage on the grid of the tube of about half a volt. The voltage was obtained from the anode of the nor-

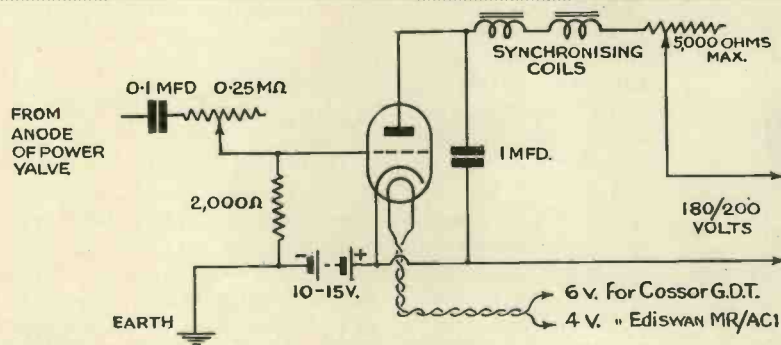

Fig. 4.—The circuit of the triggered synchroniser shown by the photograph.

critical value and will be just about to discharge through the tube; the impulse on the grid will lower the breakdown voltage of the tube just sufficiently to trigger the circuit.

This will continue indefinitely and the discharges will take place quite regularly 375 times a second, even though the discharge rate of the circuit by itself is not quite correct and may even be tending to vary slightly. The discharge is controlled entirely by the 375-cycle impulses applied to the grid, which can be easily obtained from the synchronising signals from the transmitter. Moreover, the syn-

Figs. 3 and 4 show two possible circuits. In the first the synchronising coils are inserted in series with the gas discharge tube across the condenser. The condenser charge is determined by the value of the resistance R and the capacity C, which is adjusted to give a frequency a little below 375 cycles, leaving the actual triggering to the impulses from the transmission which are applied to the grid.

The circuit of Fig. 4 is an improvement over the Fig. 3 circuit because with the original arrangement the current through the coils is limited

mal output valve in the receiver, as shown in Fig. 4. The circuit was arranged in this manner because the resistance in the grid of the MR/AC₂ must be small. Most of the components are standard but readers who wish can obtain a kit of parts for this unit from British Television Supplies.

Trigger Adjustment

Just a final word as to the adjustment. The frequency of the time-base must be slightly slower than the correct value of 375 cycles. Hook a pair of phones across the synchronis-

(Continued on page 112).



The Ediswan mercury-vapour relay used in the synchroniser.

THE SIMPLEST CATHODE-RAY RECEIVER

THE CONTROL PANEL

Here are details of the final panel of the cathode-ray receiver of which other details have been given in the three preceding issues.

THE left-hand baseboard and control panel, the construction of which is described this month, contains the focusing potentiometers and the modulation potentiometer which varies the depth of modulation applied to the shield of the tube.

Those readers who have not had any experience of cathode-ray tubes are recommended to read the articles which have appeared in this journal from time to time, and particularly those of September, 1934 (p. 418), and October, 1934 (p. 443).

The Ediswan high-vacuum cathode-ray tube used in the receiver differs slightly from the tubes of the gas-focused type in that it requires two accelerators for focusing the beam, the second being operated at about 2,000 volts and the first at 500. In the high-vacuum tube the focusing is not accomplished by variation of the negative cylinder potential, but by adjusting the relative values of the two accelerator potentials. In fact the focus is to a large extent independent of the shield potential, and it is this which makes the high-vacuum tube so good for television.

In the gas-focused type a variation of negative shield potential altered the focus of the beam in addition to altering its intensity. A heavy modulation was thus accompanied by a blurring of the definition of the picture. In the high-vacuum tube the

negative cylinder potential merely alters the intensity of the beam and makes the whole picture brighter or darker without leading to blurring of the lines.

Tube Supply

The exciter unit described in last month's issue gives a smoothed 2,000 volts supply for the cathode-ray tube, and 1,000-1,500 volts for the time-base. The potentials for the first accelerator and the negative cylinder

negative cylinder of the tube from a 30,000-ohm potentiometer to which the output of the receiver is connected, and the tapping on the potentiometer is connected to the terminal on the tube holder marked "G," i.e., that connected to the negative cylinder.

The cathode of the tube is arranged for operating from a 2-volt accumulator. This may seem out of place in an all-mains receiver, but there is a very good reason for it in that any means which will tend to avoid interference is for the best, and the cathode of the tube is a way in which interference can be introduced into the picture. The alternative is, of course, to supply the tube from a low-voltage transformer and a metal rectifier, but this is more expensive and cumbersome. For the preliminary experiments at any rate, the cell can be used and then replaced by a rectifier when the technique of the apparatus has been mastered.

From the circuit diagram it will be seen that the positive of the H.T. supply is connected to earth and the cathode of the tube is "floating." This means that the terminals of the cell will be at 2,000 volts above the potential of the chassis, and it must therefore be mounted carefully and well away from any metal parts. A slip of ebonite at the back of the lower baseboard will be the most convenient stand for it, and a fillet of wood

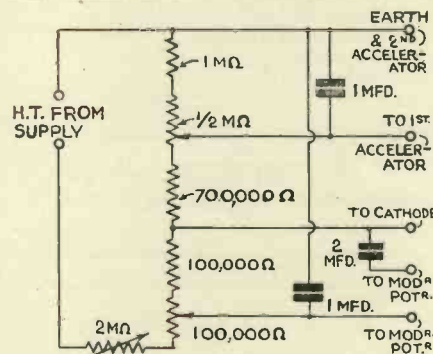

Fig. 1.—The exciter circuit.

are taken off a potential divider connected across the main H.T., and the principal components on the baseboard are those which adjust the voltage obtained from the exciter unit. The modulating signal is fed on the

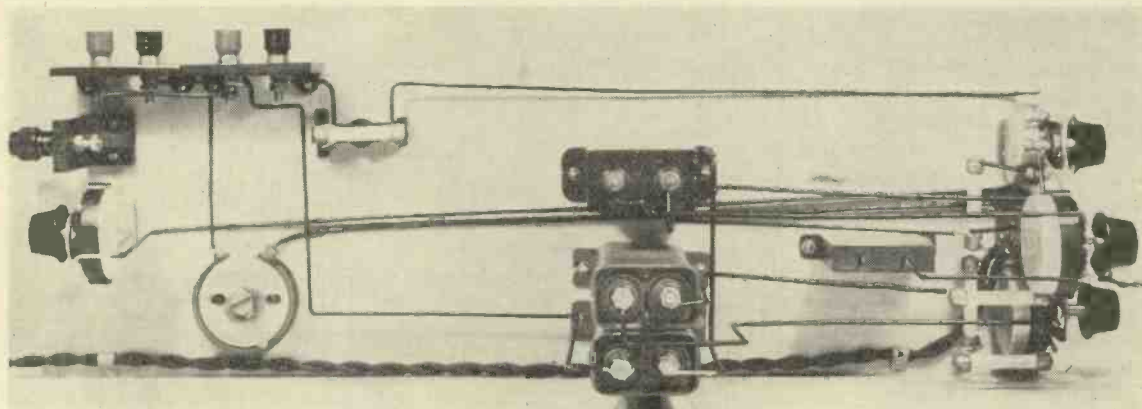

Fig. 2.—Plan view of control arrangements.

can be tacked round the cell on the baseboard to prevent it shifting.

The Circuit

Before commencing the construction, examine the circuit of Fig. 1 and note the potential divider arrangement made up of fixed resistances. In series with them is a variable resistance of 2-megohms to control the total voltage applied to the tube. This is useful to alter the sensitivity, since the lower the H.T. voltage the more sensitive the tube becomes and a given voltage on the deflector plates will produce a longer swing of the beam. However, once the voltage is set it is seldom that it requires altering, so the variable resistance has been replaced by a fixed one mounted in clips on the baseboard.

smoothing condensers will be required, across the first accelerator tap and across the shield tap. The shield itself, as said above, is connected to the bias potentiometer through the modulating potentiometer, which is isolated from the receiver by the 0.1 condenser shown in Fig. 3. The return of the potentiometer is via the 1.0 mfd. condenser to earth.

This differs slightly from the diagram shown in the December issue, in which two 0.1 condensers were shown, but the circuit is the same fundamentally.

The cathode of the tube is supplied from the accumulator through a pre-set resistance of 2 ohms and a resistance of 0.5 ohm set on a mounting bracket at the rear of the baseboard. An ammeter has not been provided on the score of extra expense, but those who can afford it

of the switch being connected in the main supply lead to the H.T. unit. It is, of course, impossible to connect the switch in the 2,000-volt lead, and nothing of this nature should be attempted.

Setting Out Components

The baseboard itself is of the same size as that used on the right-hand side of the chassis, namely, 19½ ins. by 6 ins., 5-ply. The brackets for the resistances can be screwed down, three at the front end and one at the back. When the resistances have been fitted in place, their spindles should be at the points of a 3-in. equilateral triangle, with the switch at the centre. Mark the holes for the fixed condensers as shown, but do not screw down until some of the wiring has been done in front. The

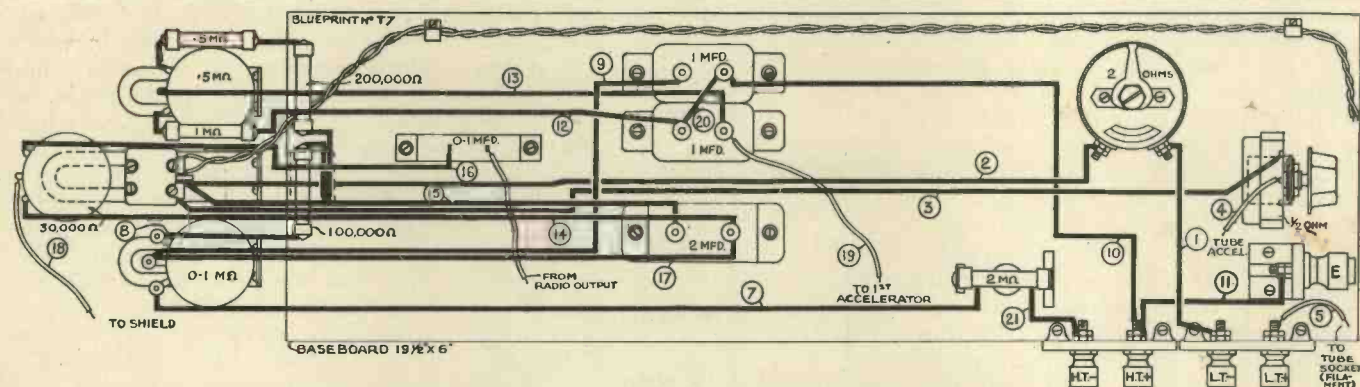

The wiring diagram of the control baseboard. A full size blueprint is available, price 1/-.

For full H.T. supply the 2-megohm value can be replaced by one of a much lower value, say, 100,000 ohms. Note that the resistance is in the negative end of the potential divider system. Turning now to the H.T. + end, the second accelerating electrode of the tube is fed direct from the H.T. supply lead. A 1-megohm fixed and a ½-megohm variable resistance give the necessary reduction in voltage to apply to the first accelerator. On the other side of the variable ½-megohm a 700,000 ohm resistance is connected and then comes the tap for the cathode of the tube (L.T. - of the accumulator).

The resistances below this tapping point will give a potential across them which is negative with respect to the cathode, and therefore the shield negative potential is taken from them on the "self-bias" principle. The reservoir condenser was included in the exciter unit, and two further

would be well advised to fit one as it removes the risk of overrunning the tube. The cathode supply is led through the double-pole switch at the front of the baseboard, the other side

Components for the Exciter Circuit.

- POTENTIOMETERS.**
1—½ megohm.
1—0.1 megohm. Reliance Mfg. Co., Walthamstow.
1—30,000 ohm.
- VARIABLE RESISTANCES.**
1—2 ohm to carry 1 amp.
1—½ ohm to carry 1 amp. (Reliance Mfg. Co.)
- FIXED RESISTANCES.**
1—2 megohm 1 watt.
1—½ megohm 1 watt.
1—2 megohm 1 watt.
or 1—0.7 megohm 1 watt.
1—1 megohm 1 watt.
1—1 megohm 1 watt.
- CONDENSERS.**
2—1 mfd. oil-filled 1,500 v. wkg. (Dubilier.)
1—2 mfd. 800 v. wkg. (Dubilier or T.C.C.)
1—1 mfd. 800 v. wkg. (Dubilier or T.C.C.)
- SUNDRIES.**
1—Grid leak holder. (Peto Scott.)
2—Terminal blocks. (B.T.S.)
4—Terminals H.T. and —L.T. and —. (Clix or Belling-Lee.)
1—Earth Terminal.
1—Terminal block for above. (Goltone.)
4—Component brackets. (Peto Scott.)
1—Double pole mains switch. (Bulgin.)
Systoflex, 18 S.W.G. wire, etc.

connections to the potentiometers are difficult to get at with a soldering iron and it is useful to leave as much space as possible.

At the back of the baseboard, the filament resistance should be mounted so that the knob does not project at all over the edge of the board. Alongside it is the earthing terminal mounted on a "Goltone" terminal block. The terminal blocks for the H.T. and L.T. terminals are screwed on to the side of the baseboard facing inwards. The holder for the H.T. dropping resistance will be seen near the H.T. terminal strip, and the preset filament resistance in front of it.

Wiring

The wiring will be made easier if the flex to the switch is soldered on before the switch is finally tightened in position. This flex should be left long enough to reach to the mains plug and socket on the lower base-

FEBRUARY, 1935

board, an extension length being joined on there to go to the exciter unit.

The L.T. wiring to the switch and resistances should preferably be done in No. 16 s.w.g. to avoid unnecessary voltage drop, but this is not very important. What is far more important, however, is to make sure that all the joints are tight and firmly soldered. A loose connection in the cathode circuit will lead to flickering of the beam.

Commence the cathode wiring by joining the L.T. - terminal to the pre-set resistance (wire No. 1) and thence

in, as the leads from each can be twisted together. Now go back and screw down all the condensers.

Make connection to them as follows: Wire No. 9 from the centre tapping on the shield potentiometer is taken to the outermost terminal on the oil-filled condenser at the edge of the baseboard. The other terminal of the condenser is linked across to the terminal on the one adjacent, which in turn is taken to the H.T. terminal and to the earth terminal (wires Nos. 10, 11). For the other oil-filled condenser: connect the terminal linked to the earth wire

The input to the modulation potentiometer is through the small 0.1 mfd. condenser which stands out in Fig. 3. The lead in the air (No. 16 in the wiring diagram) goes to the outer terminal. The other condenser tag has a flex lead soldered on which will be taken to the output of the receiver.

Wire No. 17 finally goes from the centre tap of the shield potentiometer to the 2-mfd. condenser. The circuit to the modulating potentiometer is thus made via the 0.1-mfd. condenser on one side and via the 1-mfd. condenser and earth on the other.

The completion and operation of

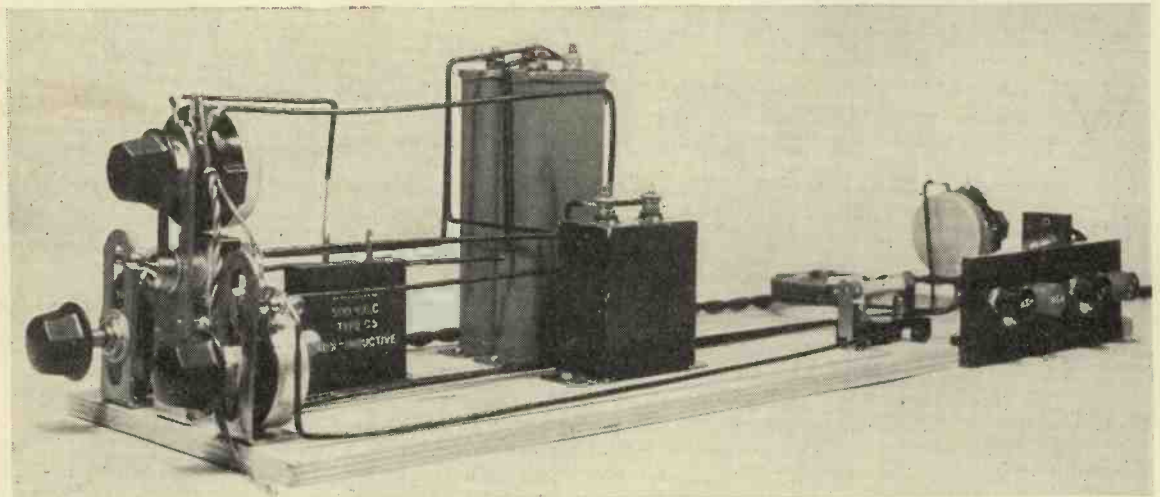

Fig. 3.
This photograph
shows clearly the
front controls.

to the switch tag (2). From the switch tag the wire (3) runs down the centre of the board to the centre contact of the variable resistance. The other contact of the resistance is connected to the tube-holder by the short flex (4). Either filament socket will do. The L.T.+ terminal is connected directly to the tube socket by a similar piece of flex (5).

H.T. Leads

H.T. - terminal on the strip goes to the fixed resistance holder (6). From the other terminal of the holder a wire (7) goes to the tag on the shield bias potentiometer. The other end of the potentiometer (not the tapping) goes to a fixed resistance (8) of 100,000 ohms, which is joined at the opposite end to one of 200,000 ohms, which is joined to one of 500,000 ohms. There are thus three fixed resistances in series, the end of the last one being soldered to the tag of the accelerator potentiometer on the extreme left of the front of the baseboard. It will be handier to solder all the three resistances in series before wiring them

through a 1-megohm fixed resistance to the first accelerator potentiometer (wire No. 12). The photograph, Fig. 2, should make this clear, the 1-megohm resistance being in the lower right-hand corner of the print, above the 200,000-ohm one which should already be in place. Wire No. 13 is now joined from the centre tapping of this potentiometer to the other terminal of the oil-filled condenser.

There finally remains the small fixed condenser (2-mfd.) between the modulation potentiometer and the cathode (wire No. 14). Wire No. 15 from the condenser goes to the junction of the two fixed resistances, 100,000 ohms and 500,000 ohms, and this junction is soldered to the switch tag which goes to L.T. - (wire No. 2).

the receiver will be described in our next issue.

Constructor's Circle

Additional Members

W. G. Parnell, "Greystones," Selborne, Hants; E. D. Parchment, "Taunton Deane," Murina Avenue, Bognor Regis, Sussex; H. J. Emerson, "Sacona," Summer's Road, Farncombe, Surrey; A. H. Handley, 23 Salisbury Road, Manor Park, E.12; T. H. Vaswani, c/o M. K. Jagtiani, 168 Abdulraheman Street, Bombay 3, India; H. Sayer, Hartley Barn, Clutton, Bristol; J. R. Park, 54 Dill Hall Lane, Church, Accrington, Lancs.; H. Heeley, 68 Clarkson Street, Ravensthorpe, Dewsbury, Yorks.; H. Dunn, 22a Roper Street, Workington, Cumberland; A. W. Wootton, 40 Gathorne Road, Southville, Bristol; J. Whetnall, 100 Church Road, Barton Northwiche, Cheshire; J. Johnson, Ller Llan, St. Luke's, Jersey, C.I.; A. Salmon, 55 Pole Street, Stepney, E.1; E. C. Sutton, 99 Parkgate, Darlington; J. Le Lievre, "Milston," St. Martin's, Guernsey, C.I.; J. Dearnley, 63 Oldham Road, Rochdale; J. Firth, 19 Tadama Road, S. Shields, Durham; C. L. Wright, 27 Larch Street, Forest Road, Leicester; R. Shore, Abbey Street, Tullow, Co. Carlow, Ireland; T. W. Twiggs, 27 Harris Street, Fleetwood, Lancs.; A. J. Davey, 2 Council House, Ashley Green, Chesham, Bucks; G. H. Fear, 65 Folly View, Penygarth, Pontypool, Mon.

FOR
DISC AND MIRROR DRUM SYSTEMS
"BAIRD" and "MERYN"
KITS AND COMPONENTS
L. LEAMAN, 97, Northfield Avenue,
W. Ealing, W.13.
*Phone—EALING 5394

Commercial Receivers for the Short-waves: No. 1.

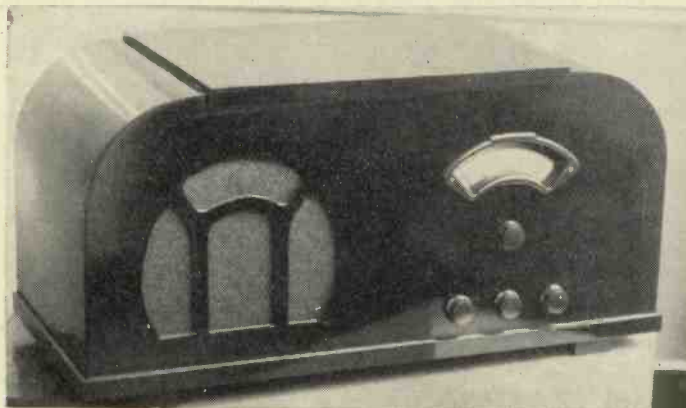

A very workmanlike chassis. All pressed steel. The components are suitable for tropical use so will stand up to the ravages of insects.

WE are glad to see the trend of design in commercial receivers leaning towards the introduction of all-wave receivers suitable for amateur station reception.

At the moment the all-wave sets available are not of the single-signal type but some of them will pull in most of the short-wave stations that you are likely to want.

One of the best receivers of this kind is the Hyvoltstar all-wave, any mains super. A real universal set. All coil switching is accomplished by one multi-contact switch so that one can tune in the broadcast band stations and immediately change over to the short waves without any fuss.

You appreciate this feature if you have been using any of the receivers

receiver on the broadcast bands except that it will bring in well over 60 stations with a very low background noise level. Selectivity is a little better than 9 kilocycles so that there is the very minimum of interference between stations. As a general rule the output is 3,000 milliwatts but this depends to some extent on the mains supply voltage. On 200 volts the output drops to about 2,750 milliwatts which should be enough for the average listener.

First of all remember that this set when on the short waves is not difficult to handle by the uninitiated as a conventional short-wave receiver. There is only one tuning control and, as the tuning dial is calibrated in wavelengths, in steps of two metres, it

merely becomes a matter of remembering which wave-band is used at the various times of the day to obtain good reception of long-distance stations.

For example, the first time we tested this receiver we may well have been excused for not receiving much in the way of American stations for we were quite unfamiliar with the operation of the receiver. However, after we had tuned the dial to 10 metres, increased the volume to maximum and done a little

retuning we heard the announcements from W8XX Pittsburgh. The little drawbacks associated with short-wave reception, such as hand capacity, special aerials and so on, did not worry us at all, although it is more than likely that a special short-wave aerial would have effected an improvement in signal strength.

20-metre American phone stations were logged very regularly during the early part of the evening, while a regular schedule was arranged with

Hyvoltstar All-wave Super

W9BHT and this was kept up for five evenings running.

40-metre amateur stations were easily logged and actually as so many stations were identified we cannot give them all here.

Although the minimum wavelength is supposed to be 18 metres we were able to log W3XAL on the 16-metre channel quite regularly during the afternoon. This rather developed into a habit and almost every afternoon saw us at three p.m. tuning in to this station.

As a general rule we could always

BRIEF TECHNICAL DATA

Brand Name: Hyvoltstar.

Model: Universal Super-Het Five.

Price: £18 18s.

Technical Specification: Combined detector-oscillator, using a high-voltage pentagrid (Ostar-Ganz B5). The single intermediate-frequency stage uses a variable- μ pentode. Second detection and automatic volume control are by means of half-wave cold detectors one of which feeds into a triode low-frequency amplifier (Ostar-Ganz A520). An output pentode (Ostar-Ganz M43) gives over 3 watts while the final valve is a half-wave rectifier type (Ostar-Ganz EG100).

Type: Table all-wave super-het.

Power Supply: A.C. or D.C. mains 110-260 volts with any frequency A.C.

Makers: UNIVERSAL HIGH VOLTAGE RADIO Co., LTD.,

28-31, Southampton Street, Strand, London, W.C.2

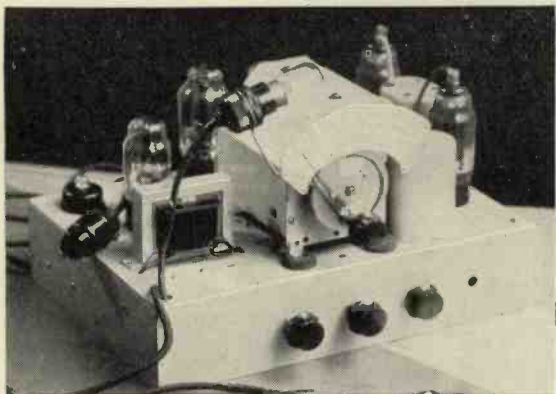

This model of the all-wave super-het is very easy to handle while the cabinet finish is particularly good.

that are merely converted broadcast sets with a short-wave converter added in front. With a set of that kind you have to remove wires and fiddle with two sets of tuning controls.

With the Hyvoltstar receiver the tuning dial is calibrated with three sets of readings so that you know to about what wavelength the receiver is tuned irrespective of the waveband. On the short waves where you may be inclined to get a little lost this is a fine idea.

We will not tell you much about the

hear about six American broadcast stations during the day and between 30 and 40 amateur American or Canadian stations on the 20-metre band.

All of the important European stations were available, while the programmes from Zeesen and Moscow were loud enough to overload the loud-speaker. The five important commercial wavebands are easily covered so that in normal conditions one can rely on picking up at least three or four good American programmes, not counting the other Europeans and the Daventry Empire stations.

Being a little more practical for a moment, take a look at the construction of the receiver chassis. It is of pressed steel with all of the major components bolted on to it.

As we have pointed out, the receiver can be used on A.C. or D.C. mains from 110 to 260 volts without having to make any alteration to the set.

The hum level is creditably low and on 200-volt A.C. supply is approximately 1.1 volt.

The Television Society

President: Sir Ambrose Fleming, M.A., D.Sc., F.R.S.

Hon. Secretaries: J. J. Denton, 25, Lisburne Road, Hampstead, London, N.W.5.
W. G. W. Mitchell, B.Sc., "Lynton," Newbury, Berks.

A MEETING of the Television Society was held at University College, London, on January 9, at 7 p.m. Chairman, T. McLance, Esq., A.M.I.R.E. (Fellow). Mr. R. Corkling, F.P.S. (Fellow) addressed the meeting on "Micro-Waves; The Propagation of Electromagnetic Waves below 1 metre."

Summary of Paper

By a number of experimental examples, Mr. Corkling demonstrated the development work which has led to the practical transmission and reception of electromagnetic waves of a few centimetres in length.

By the aid of slides the upper and lower limits of the radio-frequency band, and the relation of frequency and wavelength were dealt with. Then the design of a suitable circuit for micro-wave transmission was described, and it was shown that invariably a triode is used in a regenerative circuit, coupling anode to grid, the resultant frequency of the oscillation being dependent on the component capacity and inductance of the circuit.

For shorter wavelengths it was pointed out that the values of the components became more critical, and that due precaution had to be made to eliminate stray capacities. Even the inter-electrode capacity of the valve must be taken into consideration so that wavelengths of two metres, with care, can be produced.

In decreasing the wavelength still further, we begin to increase the frequency beyond the limit set by the vibrating electrons liberated by the cathode, because it takes longer for the electron to travel from the cathode to the anode than the desired resonating period. So that by conventional regenerative methods and standard valves it is not possible easily to produce wavelengths much below one and a half metres.

Barkhausen Oscillations

Barkhausen and Kurtz, in 1920, discovered that by oscillating the

actual electrons, they were able to produce decimetre or micro-waves. Then a description of this electronic method followed.

Using models and tennis balls, Mr. Corkling demonstrated the Barkhausen positive grid method and contrasted this with conventional methods in the use of the thermionic valve. In the latter method the electrons are drawn to the anode, but in the Barkhausen method the anode is at a negative potential, the grid being positive to the filament, and therefore the electrons liberated by the cathode are drawn forward by the grid, imparting a high velocity to the electrons, causing them to continue to the anode, but this being at a negative potential "slides them back again."

By adjusting the potential, and geometrically placing the electrodes, the electrons will oscillate about the grid, and so produce the desired frequencies.

Oscillatory generation by this method will produce very short waves, but only small outputs are possible, the output decreasing as the frequency increases, the maximum output at one metre rarely exceeding .25 watt, irrespective of the input.

Pierrett, Fill and Moiseil suggested modifications which led to electronic oscillations between grid and anode, this distance being shorter than that of the cathode-to-anode, thus producing a higher frequency and a shorter wavelength. Instability, however, remained with low outputs. Discussing practical details, it was indicated that adequate chokes were advisable to prevent H.F. losses in essential circuit conductors, and that valves of bright-emitter type having cylindrical anodes could be made serviceable, but, as these valves were not designed for high potentials and currents, the minimum wavelength is limited irrespective of the adopted circuit.

Reference was made to the new Acorn valves made by the R.C.A., now reaching this country. These valves in conventional circuits allow wavelengths of a few centimetres to be obtained.

The shorter the micro-waves the

more truly optical they become, so that parabolic reflectors are helpful and enhance directional effects.

Here Mr. Corkling described experiments using reflectors with waves fifty centimetres in length and invited mathematical suggestions likely to solve the accurate design of suitable reflectors.

Ultra-short wave receivers were then given attention, the simplest form of a receiver being a loop resonating at the radiated frequency, with a lamp as indicator. It was pointed out that comparatively large outputs are required to light even the smallest flash lamp.

Finally the lecturer described the circuit of a micro-wave transmitter exhibited by himself at the recent Physical Society's Exhibition, and illustrated on another page in this issue.

Following the reading of the paper by Mr. Corkling a demonstration of the generation of micro-waves was given by Mr. Forman, the directional properties of the waves generated being shown by their action on a distant thermo-junction connected to a reflecting galvanometer. Mr. Forman also demonstrated the advantage of using an ionised gas tube in front of the antenna.

Mr. R. R. Poole, B.Sc. (Fellow), in contributing to the discussion, gave an excellent demonstration of the action of parabolic reflectors and short waves. Using a model reflector and black and white tape strips sewn together, he illustrated change of phase with consequent loss in certain directions and generally the efficiency of the directional effect.

The paper, with discussion, will be printed in full in "The Journal of the Television Society."

The Next Television Society Meeting.

The monthly meeting of the Society will be held at Film House, Wardour Street, London, W, on Wednesday, February 13, at 7 p.m. Subject (a sound film) "The Cathode-ray Oscillograph." Mr. J. F. Herd, M.I.E.E., will give a lecture on the work of the Radio Research Board, illustrated in the film. The film is said to be the most perfect scientific film yet produced.

Tickets for non-members can be had on application to Mr. J. J. Denton, 25 Lisburne Road, Hampstead, N.W.3.

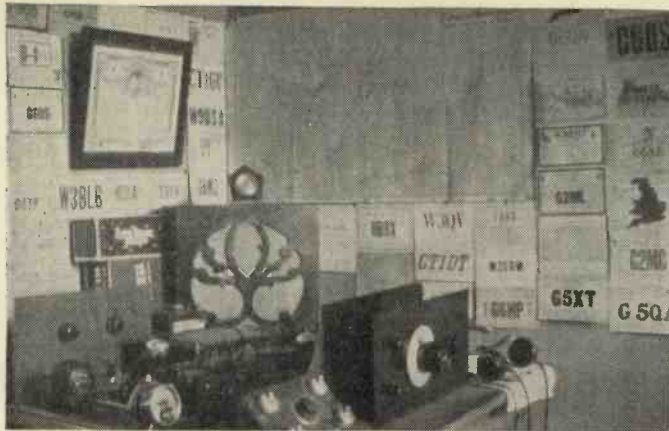

This is the receiving station of B.R.S. 1448 at Stamford Hill. Note the verifications received from all over the world.

Heard on the Short-waves

By

Kenneth Jowers

AT last short-wave fans have a medium for airing their views. In each issue of TELEVISION AND SHORT WAVE WORLD space will be devoted to listeners who wish to compare notes.

Every week my mail is so extensive that previously I have found it almost impossible to do more than to reprint very short extracts from the more interesting letters. In future it will be possible to publish enough information for you all to gauge just how the conditions are in your particular area.

Before very long I hope to have the entire country covered with reliable receiving stations from which I will have detailed reports on the local conditions.

In this way, listeners who cannot spare enough time to keep an eye on the changing conditions will be able, by referring to these notes, to know just when and on what bands to listen.

At the moment I have reports from regular listeners with powerful receivers in the eastern counties, north and south London, Cumberland, Glasgow, Wishaw, Exeter, Birmingham. Listeners in other areas who would like to help in furthering the amateur movement please drop me a line. Your assistance will be appreciated.

Here is some good news for you. K4SA of Porto-Rico who came in so well last year on the 20-metre band is now on the air again after a break of nearly four months.

Donald Morgan, B.R.S. 1338, logged him on the 20-metre band on Saturday, January 12. Other readers have confirmed this reception and some claim that signal strength peaks to R8 during the latter part of the evening.

Look out for this station but please do not send brief reports to K4SA unless you have something special to say, for in his last letter to me he said that he was snowed under with requests for cards.

B.R.S. 1338 goes on to say that 20-metre reception is good and better than this time last year. Amongst a long

string of stations heard, all using phone, were, VE₂CE, W₁IAT, W₄ZF, H₇G, VE₂AB, W₄CZG, our old friend Lloyd G. Morse, W₁CAA, the Cuban CM₂RA, W₃GAP, W₃ABN, W₃EHS, and VP₅PA. Quite a good log. Listeners in the Kenton area should note this report and see what they can do.

F. A. Beane, of Ridgewell, Essex, asks me to tell you about a special broadcast he has arranged to take place on February 13. In co-operation with Dr. K. Baumann, the operator of the Radio Club De Basle transmitter,

Amongst the stations heard at Ridgewell were COC, HB₉B, VY₄RC, XEBT, IRA, and CT₁GO. All of these stations were on phone and verifications have been received. How many listeners have a "veri" from VY₄RC?

Listeners in Lanarkshire will be well advised to get in touch with Jack Wilson, the secretary of the Wishaw and District Radio Society, who is doing great work in banding together all amateurs in his area. It is a very live club and you will get all the help you want in getting the best from the short waves.

These cards belong to the Secretary of the R.S.G.B. radio G6CL. They come from India (VU₂DX), New Zealand (ZL4BT), Africa (SU₁SG), Canada (VE4KA), and Gilbert and Ellice Islands. (VP₃B).



HB₉B, a programme of Swiss music followed by a talk in English will be radiated for the benefit of International Short Wave Club listeners.

The wavelength of HB₉B is approximately 40 metres, the actual frequency being 7,118 kilocycles with a power of 50 watts. So remember to listen to this station on the 13th of February at 22.00. Reports will be welcomed by either F. A. Beane, at Ridgewell, Essex, or by Dr. K. Baumann, Radio Club De Basle, HB₉B, Postpack No. 1, Basle, Switzerland.

Jack Wilson tells me that he uses one of my World Beaters and is getting good results from it. VK₃ME has been heard most Sunday mornings on the loud-speaker. Jack Wilson is going to test the Band-Spread receiver in Scotland for the benefit of Scotch readers and a report will be published next month.

Have you had any trouble with pentagrids on the short waves? For the past few months I have been trying to get level oscillation on the Quartz Crystal Super using English penta-

grids. So far I have not had much luck for they refuse to oscillate below 25 metres. The Ferranti valve shows signs of doing the trick but I have not an opportunity of trying more than one sample so I cannot be too sure yet. One of the best valves is the American 1C6 but these are hard to get.

Judging from the number of letters to hand readers seem to have a lot of trouble in finding a microphone that is easy to handle, gives good quality and at the same time is reasonable in price. During the past month I have had several units in for test and I have found one mike that is really worth the price asked for it. The new Dixon Reisz type unit is very heavy in a large ornamental case. You can see what I mean from the illustration.

With this microphone you can obtain very good quality and ample pick-up with only 4.5 volts applied, while with 9 volts it will pick up music from over quite wide areas. It is easy to handle, does not whistle, unless it is almost in front of the loud-speaker, while speech is sharp and clear. The price is 55s., quite reasonable for such a good unit. You can obtain one at once at Leslie Dixon's, in Upper Thames Street, which is something in these days of having to wait a week or so for the most ordinary component.

A new station you must log is the Brazilian PREO on 49.5 metres, owned

by the Radio Club of Pernambuco. There is some doubt as to the call sign, but it is either PREO or PRA8. If any readers can confirm this please let me know.

Last year the official Polish station closed down to make alterations to the



If you require a good microphone try this new Dixon Reisz type at 55s. It can be supplied complete with input transformer if you want one.

gear. This station is now on the air again and is coming over well. The call sign is SP1SI and the wavelength 47.8 metres or 6,272 kilocycles. As a general rule it is on the air from 14.00 to 18.00, but not on Sundays.

Station J1AA is radiating daily on 38.07 metres from 10.00 to 13.00. Several reports are to hand telling how this station can be heard up to R7 but

with bad fading periods and plenty of static.

There are several Japanese stations on the air at present. JVQ is on 7,470 kilocycles or 40.16 metres. JVE uses 15,666 kilocycles or 19.15 metres and radiates from 16.00 all the week round.

XGW Shanghai is coming over on 28.79 metres. Several readers have had veri's from this transmitter. The best time to hear it is from 11.00 onwards.

Many of you will remember the pleasant transmissions from Java on Tuesday afternoons at 14.40. Although these transmissions may never start up again there are some more Javanese stations that are worth logging. PLE on 15.93 metres is logged somewhere in this country every Sunday afternoon. I have not been able to obtain a schedule, perhaps some reader will oblige.

PLT on 16.10 metres has also been heard sending musical transmissions to Holland before the start of commercial transmissions. PLV sends out 31.86 metres and works two way with PDV

SAVAGE for **CHOKES**
W. BRIAN SAVAGE LTD
56-58 CLERKENWELL RD. E.C.2.

RESILIENCE

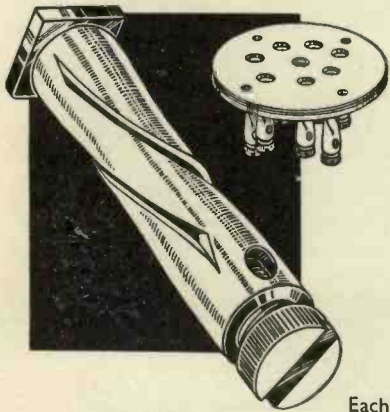

*CLIX
Points of
Advantage*

CLIX
Specified for
1-V-1
Band-Spread Receiver
(Contest Three)
Insulated Sockets,
Solid Plugs,
Spade Terminals,
Wander Plugs.

Each individual socket in Clix Chassis Mounting Valveholders is formed with a definite waist which, in conjunction with the helical slots, affords unique resilience and gives perfect contact with every type of valve pin without possibility of collapse.

Descriptive Folder "F" Free.

CLIX LECTRO LINX, LTD.
79a, Rochester Row, London,
S.W.1.

FERRANTI

A.C.-D.C. CIRCUIT TESTER



RANGES :

A.C. VOLTS : 0-15, 0-150
0-300, 0-450, 0-600.

A.C. MILLIAMPS : 0-1.

D.C. VOLTS : 0-3, 0-15,
0-150, 0-300, 0-450, 0-600.

D.C. MILLIAMPS : 0-1,
0-7.5, 0-30, 0-150, 0-750.

RESISTANCE : 0-50,000
ohms self-contained and up
to 30 megohms with external
600 volt supply.

An 0.5 mfd. plug-in Condenser Unit can be supplied (Price 5/-) to enable the instrument to be used directly to measure output voltages.

Write for Leaflet Wb 529/D

for the measurement of

A.G. VOLTAGE D.C. VOLTAGE
D.C. MILLIAMPS AND RESISTANCE

Complete with External Resistance to give
voltage ranges up to 600 volts.

Price

FERRANTI LTD., HOLLINWOOD, LANCs.
London : Bush House, Aldwych, W.C.2.

£5-15-0

THE TELEVISION ENGINEER

"An Experimental High-definition Receiver" (Continued from page 88.)
mounted on the receiver chassis, Figs. 15 and 16.

The picture was viewed by means of a mirror mounted in the adjustable lid of the cabinet. The power supply unit was mounted in the bottom of the cabinet. The rectifiers on this unit supplied 250 volts to the receiver and kinescope chassis and first and second anode supply to the kinescope. The second anode voltage on the kinescope was 4,600 volts, and the spot was focused by means of the adjustable first anode supply.

Observations on the Performance of the Receivers

No evidence of natural fading of signals in the frequency band of 40 to 80 megacycles was noted.

The sensitivity of the receivers was approximately 100 microvolts for both the sound and picture channels. However, a signal of 100 microvolts did not provide satisfactory operation of the picture channel, on account of the presence of random electrical variations usually referred to

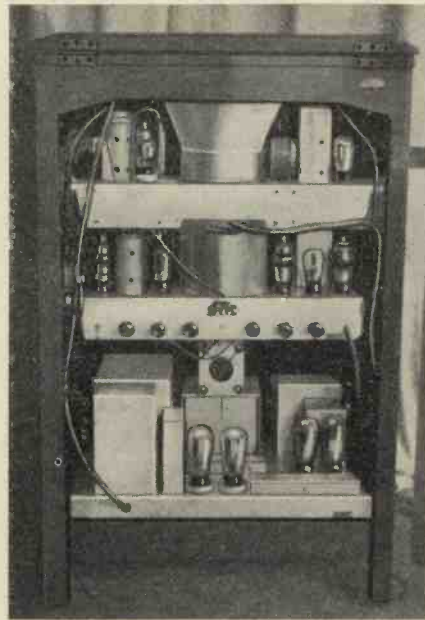

Fig. 14.—This photograph shows the internal arrangements of the receiver.

as "hiss" being present. This "hiss" disturbance limited the minimum satisfactory signal to about 1,000 microvolts. The sound side

gave a satisfactory signal on less than 1,000 microvolts. The amount of "hiss" or other interference that can be tolerated in the picture signal is greater than would be expected compared to that of the sound signal, when considered on the basis of their respective band widths. The most serious source of external interference was the ignition systems of aeroplanes. Interference was also created by automobiles driven within a hundred feet or so of the receiving aerial. These interferences were less troublesome than would be expected on the picture as compared to the sound, considering the great difference in band width.

In general the results of the tests were gratifying. Even when the programme material originated in New York City and was relayed twice, interference and other difficulties were not serious. In all the tests the performance of the apparatus was up to expectations, and the reproduced picture and sound were satisfactory and had entertainment value.

R.S.G.B. Slow Morse Tests for the Amateur.

The following stations will be radiating slow morse on the wavelengths given and at the times mentioned.

Feb.	3...0030	1820	G2OI
"	3...0930	1828.3	G2II
"	3...1000	1815	G2DQ
"	3...1030	1911	G2JL
"	3...1100	1.7 mc.	G2UV
"	10...0030	1820	G2OI
"	10...0930	1828.3	G2II
"	10...1000	1815	G2DQ
"	10...1030	1911	G2JL
"	10...1100	1.7 mc.	G2UV
"	17...0030	1820	G2OI
"	17...0930	1828.3	G2II
"	17...1000	1815	G2DQ
"	17...1030	1911	G2JL
"	17...1100	1.7 mc.	G2UV

FOR SALE: Baird Mirror-Drum Telesivisor (Grid-Cell) 9" x 4" Picture, assembled complete. Cost £25; bargain, £12. Also Double-Ended Motors, 20/- each. Discs, 16", 7/6. Fixed Mains Resistances, 3/6; variable, 6/6.—A. Shearman, 17/19, Vandiemans Road, Chelmsford.

50 ohms to 100,000

WIRE-WOUND RESISTORS



A DEFECTIVE Resistance can completely ruin the enjoyment of radio — and frequently does. Moreover, it is often difficult to trace the fault, as none but the most expensive testing equipment can definitely locate it.

When building your next set, or overhauling your present equipment, change over to Amplion resistors. They are colour coded, compact and sturdy, and all values are wire-wound, this method of construction giving the most reliable and constant form of resistance.

Price 1/- each; all values.

Specified for the "CONTEST THREE"

AMPLION

AMPLION (1932) LTD.

87-84 Rosoman Street, Rosebery Avenue, London, E.C.1

SAVAGE
FOR MAINS TRANSFORMERS
W. BRYAN SAVAGE LTD.
56-58, CLERKENWELL ROAD, E.C.2.

ELECTRADIX BARGAINS

Microphones : Microphones : Microphones

EILSEL P.A. MIKE

Wonderful value; only 55/-. With Stand (as illustrated), 65/-. Special matched Transformer, 7/6.



EILSEL MIKE.

"T.W." No. 11 TABLE MIKE. This is a splendid Microphone for speech and music. The bakelite case, containing a 2-in. mike and transformer, is on a bronze pedestal. Switch and plug socket are fitted on the case. It stands unrivalled for quality and price ... 15/-



"T.W." No. 11 15/-

A NEW PRACTICAL HOME MICROPHONE for broadcasting at home. It is a general-purpose, robust mike, with solid bakelite body, back terminals, front metal grille. No. 11. New design, finely finished ... 5/6

No. 11A. Special in solid brass body, unequalled at the price on speech and music ... 7/6

PEDESTAL MICROPHONES. Lesdix No. 10B Pedestal, 10 in. high, 12/6. Lesdix Superior No. 12BB Ring, 14 in. Pedestal, 18/6. W.E. Type Table Model, 5 in. dia., for lectures 35/-



HEADPHONES. 120-ohm Sullivan Headphones, W.D. model, at a tenth of cost. For circuit testing, fault spotting, broadcast listening, microphone experiments. Aluminium body and headbands. Maker's price to-day is 15/-. Our price 2/9 per pair, 3d. postage. 1,000 other bargains in New Sale List "T." post free.

ELECTRADIX RADIOS

218, Upper Thames Street, London, E.C.4.
Phone Central 4611.

PETO-SCOTT

B.T.S. SYNCHRONISING GEAR KIT.



For mounting on either end of B.T.S. Motor. Quickly and easily assembled. Cash or C.O.D. Carriage paid £1 7s. 6d. Yours 5/- for and 5 monthly payments of 5/-

B.T.S. Universal TELEVISION MOTOR

For both 16 in. and 20 in. scanning discs. Universal A.C. or D.C. Mains, 200-240 volts. A.C. 40-60 cycles or Battery Model, 6-volt. Cash or C.O.D. Carriage paid £1 15s. Yours 5/- for And 7 monthly payments of 5s With B.T.S. Motor Stand, 2s. 6d. extra.

B.T.S. UNIVERSAL MOTOR RESISTANCES

FIXED (Base-Mounting) Total resistance of 1,600 ohms, tapped at 600 ohms, plus 250 ohms, plus 150, plus 150, plus 150, plus 150, carrying capacity 0.25 amps. at 240 volts. Postage 6d. extra. **6/6**

VARIABLE (Panel Mounting) Wound to 150 ohms and carrying safely 0.25 amps. Smooth action and perfectly continuous contact over whole winding. **5/6** Postage 6d. extra.

B.T.S. SCANNING DISCS



Light gauge aluminium. Scanning holes perfectly punched to secure uniform scanning without preventable lines. Made in 2 sizes and ready for immediate use. 20 in. diam. **12/6** Postage 6d. extra. 16 in. diam., 7s. 6d.

FOR EVERYTHING TELEVISION CASH, C.O.D. or EASIWAY

Miscellaneous Television Components, Parts, Kits, or Accessories for Cash, C.O.D. or H.P. on our own system of easy payments. Send a list of your wants. We will quote you by return. C.O.D. orders value over 10s. sent carriage and post charges paid (GREAT BRITAIN ONLY). OVERSEAS CUSTOMERS CAN SEND TO US WITH CONFIDENCE. We carry a special export staff and save all delay. We pay half-carriage—packed free. Send full value, plus sufficient for half-carriage. HIRE PURCHASE TERMS ARE NOT AVAILABLE TO IRISH OR OVERSEAS CUSTOMERS. SEND FOR LISTS.

CONTEST THREE

KIT "A" Cash or C.O.D. **£5 : 13 : 6**
Carriage Paid.
Or 12 monthly payments of 10/6.

KIT "A." Author's Kit of First Specified parts less Valves and Cabinet.

KIT "B." As for Kit "A," but including set of 3 Specified Valves, less Cabinet. Cash or C.O.D. Carriage Paid **£7/6/-** Or 12 monthly payments of 13/3.

"KIT C." As for Kit "A," but including valves and Peto-Scott Cabinet. Cash or C.O.D. Carriage Paid **£8/6/-** or 12 monthly payments of 15/3.

These are the Parts the Author used, and contained in the PILOT KIT "A"

	£	s.	d.
1 Peto-Scott Ready Drilled Chassis ...	4	0	0
2 B.T.S. screened S/W H.F. Chokes ...	7	0	0
1 WEARITE Type H.F.P., H.F. Choke ...	3	6	0
1 Set 4 B.T.S. S/W coils, Nos. 1, 2, 3 and 4 ...	16	0	0
3 T.C.C. Type M Condensers ...	2	0	0
1 T.C.C. Tubular Condenser, .001 mfd. ...	1	0	0
3 T.C.C. Type 50, Condensers, (2) .1, 2 mfd. ...	7	2	0
1 Ferranti Type CE91, 25 mfd., electrolytic Condensers ...	3	0	0
1 Eddystone Type 922, Condenser ...	8	6	0
2 Eddystone Type 900, Condensers, ...	8	9	0
1 Eddystone Type 957, Condenser ...	6	0	0
2 Eddystone Type 933W, Vernier dials ...	15	0	0
4 Bulgin Type SW21, 5-pln Valveholders ...	6	0	0
4 Erie Fixed Resistances ...	4	0	0
1 Bulgin 2-volt .06 Dial Lamp ...	3	6	0
1 Igranic Jack and Plug ...	3	0	0
1 Bulgin Type S.104 Switch ...	2	0	0
1 Ferranti AF8, L.F. Transformer ...	11	6	0
Clix Socket, Plug, Terminals and Wander Plugs; Bushing Washers, Connecting Wire and Sleeving, Thin Flex, 6BA Nuts, Bolts and Washers and 1/4 in. Insulating Washer. ...	4	9	0

Kit "A," Cash or C.O.D., Car. Paid **£5 13 6**

3 Valves as specified ... **1 12 6**
1 Peto-Scott Contest 3 Cabinet ... **1 0 0**

EXCLUSIVELY SPECIFIED B.T.S. SHORT WAVE COILS



Set of 4 Exactly as specified **16/-** Post Free.

B.T.S. Screened S.W. H.F. Chokes

With pigtails, exactly as specified. **THE PAIR 7/-** Postage 6d. extra

PETO-SCOTT Co. Ltd.

77 (T.2.) CITY ROAD, LONDON, E.C.1
Telephone : Clerk, 9406-7
West End Showrooms : 62 High Holborn, W C1.

THE LAMP

for TELEVISION



25/-

THE MOST BRILLIANT TELEVISION LAMP YET PRODUCED.

Adaptable to ALL modulated lamp systems. Can be used for direct viewing or projection.

THE ONLY LAMP THAT CAN PROJECT A SIX INCH PICTURE ON A SCREEN THROUGH A DISC.

Many well-known consultants and experimenters agree that the "Ti" lamp is the most powerful light source available and the only lamp that can project a picture through a disc with results equal to most expensive systems.

A customer writes:—
"I take this opportunity of congratulating you on the performance of your tube."

TELEVISION INSTRUMENTS LIMITED

323, CITY ROAD, E.C.1

Telephones : Clerkenwell 0686 (2 lines).

The SAFETY you want

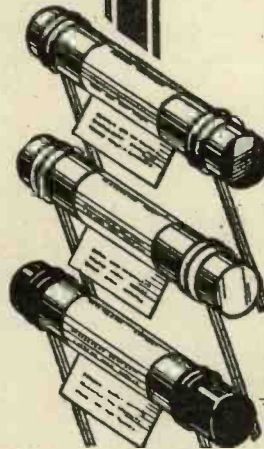

No climatic conditions or changes in temperature affect Erie Resistors. They are made of a combination of carbon and rare earth, and are specially impregnated to withstand heat and damp. Erie engineers have marched ahead in perfecting the dependable resistance. That's why the leading radio manufacturers all use Eries.

1/- PER WATT IN ALL VALUES.
Each resistor colour coded, labelled and Guaranteed.

SPECIFIED
for this month's
'CONTEST 3'

★ Genuine Erie Resistors are half-marked with the Erie label. Look for this guarantee of 100% safety.

ERIE RESISTORS

Write for the invaluable "Erie Service Instruction Booklet," post free.

THE RADIO RESISTOR CO., LTD.
1 Golden Square, Piccadilly Circus, London, W.1.

FOR THE BEGINNER

SIMPLE FACTS ABOUT
THE CATHODE-RAY TUBE

Of late the cathode-ray tube has been the subject of intense research, for one section of television workers believes that in the cathode-ray tube lies the ultimate solution. Few amateurs have had experience with the cathode-ray tube, so, therefore, the following simple explanation will prove useful as an introduction.

In effect, the cathode-ray tube is like a power valve, but with this difference: the anode current is very small.

Like the valve, the tube has a cathode and anode (see Fig. 1), but the place of the grid is taken by a cylinder which completely surrounds the cathode and which is negatively biased. The purpose of the negatively charged cylinder or "shield" as it is called is to compress the electron stream from the cathode and cause it to pass through a hole bored centrally through the anode. (see Fig. 2).

The shield plays an important part in the operation of the tube, since by altering the potential the electrons can be made to form a "jet" of fine dimensions which will pass up the tube and produce a tiny fluorescent spot where they hit the screen.

An increased anode voltage will naturally cause more electrons to pass through the hole and thus produce a brighter spot.

The electron "beam" itself behaves like a conductor carrying a

current and hence can be deflected by a magnetic field in the neighbourhood. In fact, the sensitivity of the beam is such that it is very often deflected by the magnetic field of the earth itself, but this can be overcome by slightly altering the position of the tube.

As the beam is a collection of negatively charged particles, it will be attracted by a positively charged plate, or repelled from a negatively charged one, and it is this method which is usually used for causing the beam to move and trace a pattern on the screen.

Above the electrode structure in Fig. 1 will be seen two pairs of parallel plates mounted at right angles to each

other; the beam passes between them on its way up the tube. Suppose an ordinary H.T. battery is connected between one pair of plates (Fig. 3). As the beam passes between them it will be attracted by the positively charged one and repelled by the other. On switching on, therefore, the fluorescent spot at the end of the tube will move sharply, showing that the beam has been deflected from the central position. This is the simplest use to which the tube can be put—it will act as an electrostatic d.c. voltmeter, in which the voltage is indicated by the position of a spot of light. It has the advantage that it cannot be overloaded, since a high voltage will deflect the beam off the screen altogether, but will not otherwise affect the tube. If the polarity of the battery is reversed, the spot will be deflected by an equal amount in the opposite direction.

Now suppose the battery is replaced by an alternating voltage. The beam will be deflected first one way and then the other, conforming to the change of polarity on the plates. The spot will now appear as a line, since the eye will not be able to distinguish the rapid swinging to and fro of the beam. The length of the line will be proportional to the total peak voltage swing and the tube is now acting as an electrostatic a.c. voltmeter, giving peak readings.

If the potential is applied to the other pair of plates, the beam will be deflected in a plane at right angles to its original direction, and by applying a suitable value of potential to each of the four plates, it is possible to move the beam to any spot on the screen.

Now let us make the circuit a little more complicated by applying an a.c. voltage to each pair of deflector plates simultaneously. If the voltages are

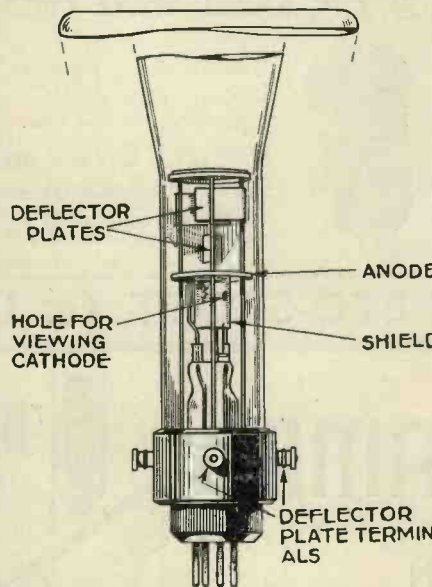

Fig. 1.—The details of the electrode system of the cathode-ray tube.

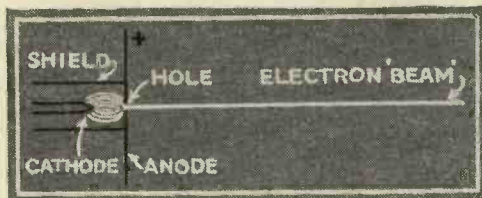

Fig. 2 (left).—The electron beam passes through a hole in the anode; note the effect of the shield.

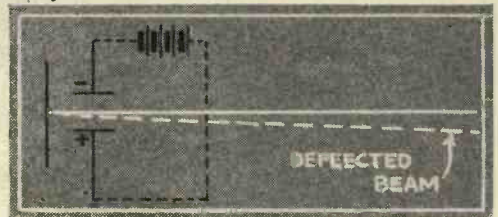

Fig. 3 (right).—The beam is attracted by the positively charged plate.

current and hence can be deflected by a magnetic field in the neighbourhood. In fact, the sensitivity of the beam is such that it is very often deflected by the magnetic field of the earth itself, but this can be overcome by slightly altering the position of the tube.

As the beam is a collection of negatively charged particles, it will

be connected between one pair of plates (Fig. 3). As the beam passes between them it will be attracted by the positively charged one and repelled by the other. On switching on, therefore, the fluorescent spot at the end of the tube will move sharply, showing that the beam has been deflected from the central position. This is the

"in phase," i.e., if they have the same instantaneous value at the same time, the beam will tend to move in two planes at once! Actually, of course, it will move in a path which is a compromise between the vertical and horizontal. If the voltages are equal, the line will slope at an angle of 45 degrees to the vertical.

"Modern High-definition Television"

(Continued from page 96.)

statically by means of deflecting plates within the tube, or electromagnetically by deflecting coils outside the tube. Both methods are in general use.

Fig. 5 shows a typical scanning circuit in which an H.F. pentode is used as the constant-current device. When the condenser C is charged to a given potential the Thyatron breaks down and a discharge takes place. The breakdown voltage depends on the negative bias applied to the grid of the Thyatron, and this bias controls the amplitude of the scan. Similarly the positive potential on the screen of the pentode controls the charging rate and hence the frequency of the circuit.

1935 EDITION...
FREE!

A New and greatly enlarged edition of "ENGINEERING OPPORTUNITIES" is just off the Press. It describes the easy way in which you may become an A.M.I.C.E., A.M.I.Mech.E., A.M.I.E.E., A.M.I.A.E., A.M.I.W.T., etc.

Under our "NO PASS—NO FEE" Guarantee

and contains the world's widest selection of courses in all branches of Civil, Mech., Elec., Motor, Aero., and Radio Engineering, Building, etc.

If you are earning less than £10 a week, you cannot afford to miss this unique guide to a first-class job.

DON'T DELAY—send for FREE copy of the Handbook to-day. No cost or obligation of any kind.

THE BRITISH INSTITUTE OF ENGINEERING TECHNOLOGY, 337, Shakespeare House, 29/31, Oxford Street LONDON.

268
PAGES
Free!

**3 Reasons why
YOU SHOULD JOIN THE
OLDEST RADIO SOCIETY
IN THE WORLD.**

Because

1. Its **Monthly Journal**, the T. & R. Bulletin, is devoted exclusively to short wave developments and news of amateur interest.
2. Its **Research and Experimental Section** enables members to collate the results of their tests and experiments. Television and Ultra High Frequency work are but two of the specialised groups operated by the Section.
3. Its **QSL Bureau** (which handles nearly half a million cards annually) is the most efficient free Bureau in the world.

Membership details will be sent on receipt of a stamped addressed envelope.

If you have not yet read the second Edition of *A Guide to Amateur Radio*, write for a copy to-day. This Handbook contains 80 pages of up to date information dealing with short wave transmitters and receivers, and explains in detail how to obtain a Government Licence. The price is 8d. post free.

All communications to
The Secretary (Dept. S.W.),
RADIO SOCIETY OF GT. BRITAIN,
53 Victoria Street, London, S.W.1.

EDDYSTONE

SHORT
WAVE COMPONENTS



STRATTON & Co. Ltd
EDDYSTONE WORKS
BROMSGROVE ST.
BIRMINGHAM 5.

LONDON SERVICE DEPOT:
WEBB'S RADIO STORES, 14, Soho Street, Oxford Street, W.1.



SEASON
1935

Better service results from mentioning "Television" when writing to advertisers

Trade Notes of the Month

Reports on Apparatus Tested

Oil-filled Condensers for the Amateur

HIGH-TEST voltage condensers for use in speech amplifiers for television work have been very difficult to obtain in the past unless you were prepared to pay a very high price for them. The manufacturers knew that with the high-voltage type of gaseous rectifier with 900 to 1,000 volts paper condensers were hardly satisfactory, for the voltages are inclined to surge to a high figure.

The Dubilier Company have now overcome these difficulties by the introduction of their type 951 oil-immersed



2,000-working oil-immersed Dubilier condenser. Can be used in any position.

paper dielectric condensers. These condensers vary in capacity between .02 microfarads to 4 microfarads, with a capacity tolerance of plus or minus 15 per cent. They will really be a boon to constructors of reasonably high-voltage amplifiers.

Each condenser consists of a multiple paper dielectric condenser element, impregnated and oil-immersed by a special process and then hermetically sealed into a sheet metal container. Containers are provided with fixing feet and finished in grey, contacts being made by means of a large nut and bolt.

Actually for capacity in relation to working voltage these condensers are the most compact we have ever tried, while as the price is reasonable we can use a really high-voltage condenser without increasing the cost too much. In addition to the high breakdown voltage the insulation resistance is very high so that the lower capacity condensers are eminently suitable for coup-

ling condensers in high-quality resistance-capacity amplifiers.

The .02 microfarad condenser tested at 3,000 volts with a working voltage of 1,500 costs 10s. 2-microfarads, 1,000-volt working, costs 13s., while a 4-microfarad, 1,000-volt working, costs 17s. 6d. A 2,000-volt working 4-microfarad condenser is also available at 21s.

We have been trying various samples of these condensers with great success, power factor being of a high order, and next month we are going to publish an amplifier, which we have been wanting to publish for a long time, to give 18 watts A.C. output, with quality of the highest order. This will use several of these new Dubilier oil-immersed condensers.

A New Battery Valve by Ferranti

Listeners are frequently in a quandary as to the best type of valve to use in their short-wave receivers. Poor oscillation below 20 metres can often be attributed to using a detector valve of the wrong impedance.

The new Ferranti L2 is rather an unusual valve. Its impedance is 6,800 ohms with a mutual conductance of 1.6 milliamperes per volt, giving an amplification factor of 10.9. The filament voltage is 2 with a current of .1 ampere. This valve is half-way between the small power and low-frequency types, and although it has not been designed for detection, the amateur would be



This new battery valve by Ferranti makes a very smooth detector.

well advised to consider it in this respect. It will oscillate quite freely down to very low wavelengths without difficulty. No traces of microphony are noticed providing the anode voltage is kept to a reasonable level and the loud-speaker is not actually on top of the receiver. When used as a detector with 75 volts high-tension the anode current is in the region of 3.5 milliamperes. Under these conditions oscillation is very smooth, and altogether it is a very satisfactory valve.

It can also be used as an oscillator in a super-het or as a driver in a class B stage. With a maximum anode voltage of 150 and biased 6 volts negatively, anode current is 6.5 milliamperes. The actual maximum emission is 18 milliamperes.

A New-type Mervyn Disc

We have recently had the opportunity of testing a new pattern Mervyn disc. This, as the photograph shows, is quite plain and it may appear a reversion to the original type. It is, however, an

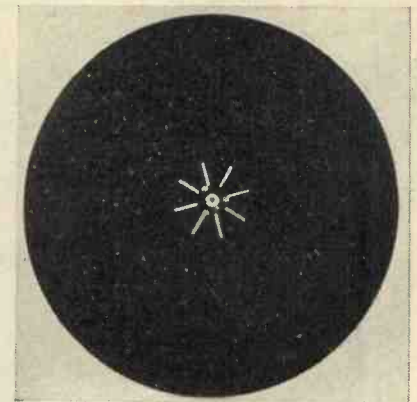

The new plain Mervyn disc.

improvement in several ways; the thickness of the metal used has been gauged so that the disc runs with a very high degree of accuracy and as it has not been subjected to any pressing process in manufacture it is perfectly true. We were impressed by the accurate positioning of the scanning holes and in use it was found that no overlap or spacing was discernible, a perfectly even field of light being presented. Whether more air friction is caused by a plain disc is a debatable point but we found that the smallest size of motor provided enough power to drive it well over the necessary speed. The diameter is 15½ ins. and the price 6s.

SAVAGE
FOR CATHODE RAY TUBE
TRANSFORMERS
W. BRYAN SAVAGE
56-58 CLERKENWELL ROAD, E.C.2

**SPAN the ATLANTIC !
'HYVOLTSTAR'
UNIVERSAL AC-DC
RECEIVERS get America
at full loud-
speaker strength**

HYVOLTSTAR Universal Superhets are the supreme receivers. Fidelity and tone superb on all wave bands. Refinements include silent Fluidlight tuning and A.V.C.

Test HYVOLTSTAR superiority, have a Receiver on approval! Write for particulars and interesting leaflet T.

UNIVERSAL HIGH VOLTAGE RADIO LTD.,
28-29, Southampton Street, Strand, W.C.2. Phone: TEMple Bar 4985.

ALL WAVES.
From 100-250 v. without alteration

Universal All-Waves Super 5 (19 to 2,000 meters)
Chassis with valves 14 gns.
Complete Table Model 18 gns.
Table Radiogram 24 gns.

Universal All-Waves Super 7 (13 to 2,000 meters)
Chassis with valves 22 gns.
Table Radiogram Model 30 gns.
Table Model 26 gns.
Console Radiogram with automatic Record-changer 40 gns.

OSTAR-GANZ
UNIVERSAL HIGH VOLTAGE VALVES

Streets ahead of any other Universal in efficiency and economy. The only Universals that can be wired in parallel. Any Mains AC/DC, any Voltage. No Mains Transformers, Barretters or Step-down Resistances. Get OSTAR GANZ and get the best.

Are the ideal valves for Television Receivers and Amplifiers.

Write for interesting folder T to:
EUGEN J. FORBAT,
Sole Agent,
28-29, Southampton Street,
Strand, London, W.C.2.
Telephone: TEMple Bar 8608

WATCH OSTAR-GANZ DEVELOPMENTS !

**THE
TELEVISION SOCIETY**

President: Sir AMBROSE FLEMING, M.A., D.Sc., F.R.S.

Founded in 1927 for the furtherance of Study and Research in Television and allied Photo-electric Problems.

Ordinary Fellows are elected on a Certificate of Recommendation signed by Two Ordinary Fellows, the Proposer certifying his personal knowledge of the Candidate. The Admission Fee for Fellows is half-a-guinea, payable at the time of election, the Annual Subscription is £1 payable on election, and subsequently in advance on January 1st in each year, but the Annual Subscription may be compounded at any time by the payment of Ten Guineas.

Any person over 21, interested in Television, may be eligible for the Associate Membership without technical qualifications, but must give some evidence of interest in the subject as shall satisfy the Committee. For Associate Members the Entrance Fee is 5/-, payable at the time of election, with Annual Subscription 15/-, payable in advance on January 1st in each year.

Student Members.—The Council has arranged for the entrance of persons under the age of 21 as Student Members, with Entrance Fee 2/6 and Annual Subscription 10/-, payable as above.

The Ordinary Meetings are held in London on the second Wednesday of the month (October to May inclusive) at 7 p.m. The business of the meetings includes the reading and discussion of papers. A Summer Meeting is usually held, and affords Members the opportunity of inspecting laboratories, works, etc. A Research Committee and the preparation of An Index of Current Literature are active branches of the Society's work.

The Journal of the Television Society

is published three times a year. All members are entitled to a copy; and it is also sold to Non-Members, at an annual subscription of 15/-, post free.

Forms of proposal for Membership, and further information regarding the Society, may be obtained on application to the Business Secretary, J. J. Denton, 25, Lisburne Road, Hampstead London, N.W.3.

Registered Trade Mark

WEARITE
SPECIFIED for the
CONTEST THREE

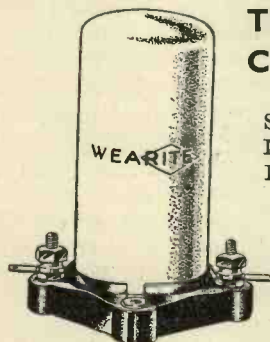

The WEARITE H.F.
CHOKE (Type H.F.P.)

Self Cap., 4.5m. mfd.
Induct., 255,000 m.h.
D.C. Resist., 300 ohms.

3'6

Ask for details of the H.F.P.A.
(with pigtail) and H.F.P.J.—
the junior choke

**FILL IN
THIS
COUPON
FOR
NEW
WEARITE
BOOK**

Please send copy of your Booklet A834 with technical data on Coils, Chokes, Transformers and Theoretical Circuit Diagrams also details of your "Universal" Coil.

To Messrs. WRIGHT & WEARE, LTD.,
740, High Road, Tottenham, N.17

Name

Address

Tel. 2/35

CA6332



The
S. G. Brown
TYPE "A"
HEADPHONE

Specified for the
I-V-I
BAND SPREAD RECEIVER
(CONTEST 3)

This type has long been recognised throughout the world as the finest obtainable for short wave reception. Signals and speech are perfectly clear. Constructed to give the very highest degree of sensitivity. The double head band is adjustable and comfortable to the head. This type of headphone is used by H.M. Navy, the Dutch, Swiss and French Telegraph Services, and British and Foreign Air Services. Undoubtedly the finest headphone you can use. The price is per pair, 50/-.

Sole manufacturers under exclusive licence of S. G. Brown, F.R.S.

The NATIONAL RADIO SERVICE Company
(N.R.S. Ltd.)
15/16 Alfred Place, Tottenham Crt. Rd., London, W.C.1.
Tel. Museum 7651 (5 lines).

Mention of "Television" will ensure prompt attention

"Recent Television Developments"

(Continued from 82)

though another portion is always open, thus producing "frame" and "line" synchronising signals respectively.

Another rotating arm D₁ forms a "safety" shutter which prevents light from the lamp L from reaching and damaging the film before the film "drive" comes into operation. The frame and line signals are reversed in phase, i.e., they are fed to the transmission channel on opposite sides of a datum line which corresponds to the "black" portions of the picture.

When a cathode-ray receiver is being used, the arrangement prevents the scanning-beam from coming to rest and so burning a hole in the fluorescent screen.—(*Electrical and Musical Industries, Ltd., and C. O. Browne.*)

Synchronising Signals

(Patent No. 419,441.)

The amplitude of the synchronising signals used in television is limited so that the impulses applied to the

generator of the saw-tooth oscillations are kept substantially constant. For instance, the grid and plate voltages on the first valve of the receiver are so chosen that the amplitude is limited in one direction by the flow of grid-current, and in the other direction by the cut-off of anode current. This also serves to eliminate "ground noise" and similar disturbances below a certain level.

The framing signals being of longer duration than the "line" signals are separated by means of a resistance-condenser combination having a high impedance to the former and a low impedance to the latter. Successive impulses of the longer duration are applied through a filter circuit to a separate blocking oscillator.—(*Electrical and Musical Industries, Ltd., C. O. Browne, and J. Hardwick.*)

Summary of Other Television Patents

(Patent No. 418,527.)

Improvements in "colour" television and in light-filters for use

therein.—(*J. L. Baird and Baird Television, Ltd.*)

(Patent No. 419,120.)

Scanning-device comprising a central reflector and a circular arrangement of inwardly-facing mirrors.—(*I. M. K. Syndicate, Ltd.*)

(Patent No. 419,233.)

Improvements in light-sensitive cells of the type in which the sensitive material is deposited on a glass surface.—(*H. Fitzherbert and H. G. Hughes.*)

(Patent No. 419,298.)

Time-base circuits for controlling the traverse of the electron stream in a cathode-ray tube.—(*A. C. Cossor, Ltd., and O. S. Puckle.*)

(Patent No. 419,307.)

Photo-electric cells responsive to the movement of objects relatively small in comparison with the total field of view.—(*A. S. Fitzgerald.*)

(Patent No. 419,379.)

Electrode assembly for cathode-ray tubes.—(*Marconi's Wireless Telegraph Co., Ltd., and W. E. Benham.*)

"R. W. Corkling's Micro-wave Transmitter"

(Continued from page 92)

this latter feature which retains stability. As will be seen from the circuit due precaution has been taken to prevent H.F. dissipation. Especial attention has also been paid to the insulation in this direction. It will be noted that the filament of each valve has independent control, which enables the valves to be carefully matched, which is very essential.

Specially developed valves are desirable although it is possible to utilise certain valves designed for conventional use, the performance being more or less limited by the maximum potentials which can be applied to the grids.

The wavelength range of this transmitter is approximately 50 cm. to 75 cm. The wavelength being determined by tuning the anode lecher system. The output is controlled by the cathode system as already explained.

By carefully selecting the valves an output of 10 watts can be obtained with a wavelength of 50 cm. A $\frac{1}{2}$ -wave dipole aerial of novel design was incorporated. This was constructed of $\frac{1}{4}$ -in. copper rod; this material was used throughout the transmitter to ensure perfect rigidity.

As the values of the respective

potentials is very critical, it will be seen that the set is provided with an ample supply of instruments, to enable the voltage and current of the filaments, grids and anodes to be carefully adjusted.

The dimensions of the transmitter are: 4 ft. long, and 7 ins. wide. The useful range of this set is about five miles.

"A Triggered Synchroniser"

(Continued from page 98.)

ing coils and listen to the note and compare it with the note of the transmission. It should be just a little lower in pitch. If it is higher, so that the frequency of the time-base is more than 375 the unit will not work properly. Keep the frequency low and when you apply the synchronising voltage to the grid you will hear the note suddenly increase in pitch.

Start with full resistance in, which will give a low note, and gradually reduce the resistance to raise the frequency. Make sure the centre point of the heater winding is earthed. Otherwise you may have trouble. If you reduce the resistance too much a continuous discharge may take place. In this event put the resistance back to normal and disconnect the A.F. momentarily.

The motor, on the other hand,

should be running slightly too fast so that the synchronising impulse can check the speed sufficiently to keep it in step. It is much more difficult to speed the motor up than to slow it down and if the motor is running too slowly you may find your synchronism ineffective. This applies to any system of synchronising, whether using this new method or not.

Finally, use as little synchronism as possible. If the voltage applied to the grid of the tube is only just enough to trigger the circuit there can never be any false synchronism due to a black hat or other object near the top of the picture because the circuit will not be in a suitable condition for triggering.

Those who make up this circuit will, I feel sure, be pleased with the results. It is more certain than the usual brute force methods. The current drain on the H.T. is about 20 milliamperes. A simple mains unit with very little smoothing is all that is required. The same supply as is used for the neon lamp can be used if desired.

SAVAGE FOR AMPLIFIERS OF ALL TYPES
W. BRYAN SAVAGE LTD
56-58, CLERKENWELL ROAD, E.C.2

WE HOLD LARGE STOCKS OF UNUSED RADIO GOODS ALL GUARANTEED PERFECT AMERICAN VALVES OF EVERY DESCRIPTION

Only first-class makes such as Arcturus and R.C.A. stocked, guaranteed for 6 months, 247, 235, 551, 89, 18, 19, 46, 59, 6A7, 15, 42, 41, 38, 39, 78, 75, 57, 58, 224, 44, 36, 235, 83, 43, 5Z3, 12/-; 25Z5, 12Z3, 14/6; UX171, UX199, UX280, UX245, UX226, UX227, 7/6; UX250, UX210, UX231, 17/6; UX867 photocells, 25/-; all other types of American valves in stock; we also stock transmitting valves.

- OSRAM L55 ... 12/- DA60 ... £3/17/0 MARCONI T250 ... £3/0/0 AMERICAN VALVE HOLDERS, UX or UY, 8d. Carriage paid. Cash with order; or sent C.O.D.

We specially welcome inquiries or orders from potential customers abroad. A comprehensive list "T.N." will be sent upon request.

WARD

45 FARRINGDON STREET, LONDON, E.C.4. TELEPHONE: HOLBORN 9703

Imperial College of Science and Technology, South Kensington, London, S.W.7.]

Physics Department (Technical Optics Section).

A Course of Six Lectures

By

Dr. W. D. Wright, D.Sc., A.R.C.S., D.I.C.,

On

The Optical Principles of Television

Will be given on

Tuesdays and Thursdays at 4 p.m., commencing on February 19th, 1935.

For further particulars and for admission tickets, application should be made to the Registrar of the Imperial College at the above address.

"TELEVISION" COUPON

FOR FREE INQUIRY SERVICE

Name _____

Address _____

February, 1935.

INDEX TO ADVERTISERS

Table listing advertisers and their page numbers: Amplion... 106, Bennett Television, Ltd. Cover iii, British Television Supplies, Ltd. Cover iv, Dixon, Leslie, & Co. 106, Edison Swan Electric Co. Ltd. Cover ii, Ferranti, Ltd. 105, Lectro Linx, Ltd. 105, Mervyn Sound & Vision Co., Ltd. 50, National Radio Service 111, Ostra Ganz 111, Peto Scott 107, Radio Resistor Co. Ltd. 107, Radio Society of Gt. Britain 109, Sanders, H. E., & Co. Cover iii, Scopphony, Ltd. 49, Sound Sales 49, Stratton & Co., Ltd. 109, Television Instruments, Ltd. 107, Television Society 111, Ward Cover iii, Westinghouse Brake & Saxby Signal Co., Ltd. 49, Wright & Weaire Ltd. 111

NEW BENNETT OPTICAL UNIT (REGD.)

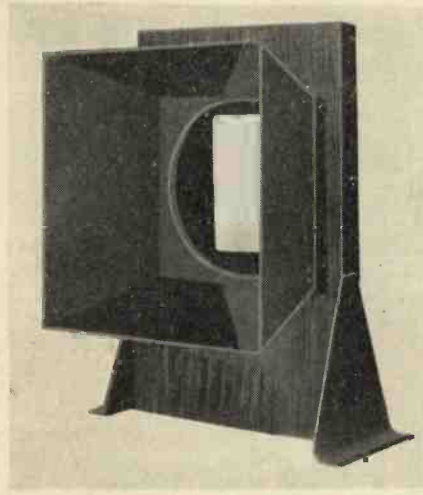

FOR BEST RESULTS WITH DISC RECEIVERS. PRICE 10/- COMPLETE WITH SUPER LENS.

Your Radio Dealer can supply this unit.

- COMPLETE TELEVISION RECEIVER ... 70/- NEW VIEWING TUNNEL OPTICAL UNIT 10/- DUPLEX NU-GLO LAMP AND HOLDER 13/3 AC/DC TELEVISION DESIGNED MOTOR 20/- PAIR OF DRILLED MOTOR BRACKETS 4/6 TAPPED AND VARIABLE RESISTANCES 10/6 SCANNING DISC READY FOR USE ... 6/- SLOTTED BASEBOARD and TERMINALS 5/9

All apparatus sent post free over 10/-, or C.O.D.

Separate Components Supplied. Lists Free.

PRACTICAL TELEVISION HANDBOOK 1/- BENNETT TELEVISION Co. REDHILL

H. E. SANDERS & Co

Supply all Up-to-date Apparatus

1 to 1 TRANSFORMER for Neon Coupling. This is a really excellent Model, having two Variable Stud Switches for Change over from Ratios 1-1, 2-1, 3-1, or 1 1/2-1, and 1-2, thereby making an Ideal Component. Only a few available and cannot be repeated at the Price 13/- Post Free.

USE A "MERYVN" DUPLEX NU-GLO 16" LAMP AND A SANDERS 4" NON-DISTORTING LENS AND GET MORE BRILLIANT AND LARGER PICTURES.

Neon 12/6 Post 6d. Lens 4/6 Post 6d.

SUPER LENS 5" will give extra Large Picture. Price 7/6. post 6d.

DISC RECEIVER KIT, including Nu-Glo Lamp and Baseboard Fittings. Price 60/- HANDBOOK "EASY LESSONS IN TELEVISION." 2/- post free.

Send for Latest Illustrated List

H. E. SANDERS & Co 4, GRAYS INN ROAD, LONDON, W.C.1

Telephone: Chancery 8778

FOYLES FOR BOOKS

New and secondhand books on every subject. Catalogues free on mentioning your interests.

119-125, Charing Cross Rd., London, W.C.2 Telephone Gerrard 5660 (10 lines)

MISCELLANEOUS ADVERTISEMENTS

The charge for advertisements in these columns is 12 words or less 2/-, and 2d. for every additional word. All advertisements must be accompanied by remittance. Cheques and Postal Orders should be made payable to Bernard Jones Publications Ltd., and crossed, and should reach this office not later than the 15th of the month previous to date of issue.

A. MATHISEN, Chartered Patent Agent, F.Tel.S. Patents, Designs and Trade Marks.—First Avenue House, High Holborn, W.C.1. Holborn 8950. Telegrams: "Patam" Holb., London.

PATENTS, Trade Marks, Advice. Handbook and Consultations Free.—B. T. King, Patent Agents, G.B., U.S.A. and Canada, 146a, Queen Victoria Street, London. 48 years' references. Phone: City 8161.

TELEVISION—A BRIEF SURVEY. A handbook for the beginner giving circuit for receiving. 7½d.—Post Free to Messrs. H. Bailey & Co., Ltd., Television and Radio Engineers, Denton, Manchester.

PLEW TELEVISION, Ltd. (in Liquidation). Having purchased the entire stock of the above, we are offering same under manufacturer's cost; chassis, complete with 4 valves, 59/6; cabinets, 7/6; lenses, 5/6 pair; motors, 10/-; mains leads, with plug adapter, 1/-; etc.; send stamped addressed envelope for full list.—H. L. Smith & Co., Ltd., 289, Edgware Road, W.2.

SALE. Television Motors, double ended, 15/-; Complete Synchroniser, 11/-; Kerr Cell, 10/- Stamp for list.—Kingstone & Co., 372, Essex Road, London, N.1.

"PRACTICAL TELEVISION HANDBOOK." By B. Bennett, A.T.S. Television simply explained: Receiver construction and operation.

"PAREX" METAL CABINETS. Mottled and lacquered aluminium cabinet for I.V.I. as specified, 14s. 6d. net, baseplate, 3s. 6d.—E. Paroussi, 10, Feather stone Bldgs., W.C.1. Phone: Chancery 7010.

\$40.00—Inventions patented—United States.—Samuel Goldstein, Registered Attorney, 275, East Gunhill Road, New York City:

THE CONSTRUCTORS' CIRCLE

Application for Membership

To be filled in and sent with a stamped envelope for reply to the Editor, "Television," 58-61, Fetter Lane, London, E.C.4.

(1) I already subscribe to your journal at the address below.

(2) I have placed a regular order for TELEVISION with my booksellers, Messrs.....

and desire to be enrolled as a member of the TELEVISION "Constructors' Circle."

Please send membership badge free of charge to

Name (in block letters)

Address

*Strike out lines not applicable.

There is news in the "Television" advertisements

B.T.S. TELEVISION and SHORT WAVE COMPONENTS and KITS

B.T.S. TELEVISION MOTOR

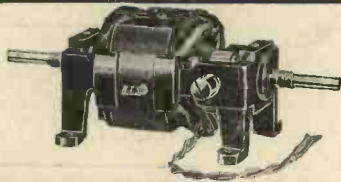

Runs with perfect precision. Heavy cast aluminium frame ensures freedom from mechanical vibration and absence of noise. Ball bearings provide even running. Suitable for both 16 in. and 20 in. Scanning Discs. Cat. No. M/1 Universal A.C. or D.C. Mains, 200-240 volts. A.C. 40-60 cycles or Battery Model. Cat. No. M/2 6-volt. Price **35/-**
B.T.S. Motor Stand for above 2s. 6d.

B.T.S. Synchronising Gear Kit

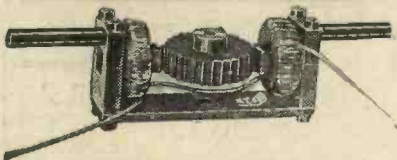

Perfect synchronisation, with floating images reduced to a minimum. Expertly designed and constructed. Quickly and easily assembled. For mounting on either end of B.T.S. Universal Motor. In carton with assembly instructions. Cat. No. S/8. Complete Kit **27/6**

TELELUX FOR BRIGHTER PICTURES



Invented to Perfect Disc Television. The process of manufacturing TELELUX is one of the latest Television patents, and results in a very highly-developed lamp essential to perfect Disc Television reception.

6/6

Due to the special opaque external coating, "glare" and "beehive" lines are entirely eliminated. Bright clear and well-defined images. For use with 16 in. and 20 in. discs. TELELUX lights at 180 volts, and operates with only 18 m/a passing through it.

If you experience any difficulty in obtaining B.T.S. products, send direct.

SPECIFIED for the CONTEST 3

B.T.S. Short Wave Coils



No. C1. 13-26 metres ... 4/-
No. C2. 24-52 metres ... 4/-
No. C3. 46-96 metres ... 4/6
No. C4. 90-190 metres ... 4/6
Standard 4-pin valve holder fitting.

SET OF FOUR

EXACTLY AS SPECIFIED **16/-**

B.T.S. Screened SHORT - WAVE H.F. CHOKES

WITH PIGTAILS, EXACTLY AS SPECIFIED **7/-**
THE PAIR

Type No. 104



THERE ARE NO SUBSTITUTES

for B.T.S. Components. Only B.T.S. are good enough for the leading set designers. . . . only B.T.S. will guarantee YOU 100 per cent. success.

B.T.S. SCANNING DISCS.

Light gauge aluminium. Centre-boss is an 8-ribbed black Bakelite moulding faced white to give true Stroboscopic effect, and thereby visual speed indication. Scanning holes perfectly punched to secure uniform scanning without preventable lines. Made in 2 sizes, and ready for immediate use. 20 in. diam. Cat. No. D/4 **12/6**

16 in. diam. Cat. No. D/3, 7/6.

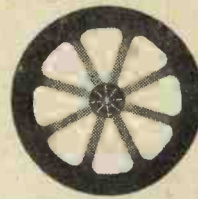

OBTAINABLE from ALL GOOD RADIO DEALERS

B.T.S.



DESIGNED and constructed by a SPECIAL STAFF OF EXPERTS, consistently specified by the leading Radio and Television journals, B.T.S. Television and Short Wave Components are the most RELIABLE you can buy. B.T.S. were the first manufacturers of QUALITY Television and Short Wave apparatus for the Home Constructor. B.T.S. prices to-day are the lowest obtainable. Send for complete lists of B.T.S. Television and Short Wave Kits and Components. We manufacture ALL parts for the needs of the Constructor and serious Experimenter.

B.T.S. INDIRECT DRIVE DISC TELEVISION KIT

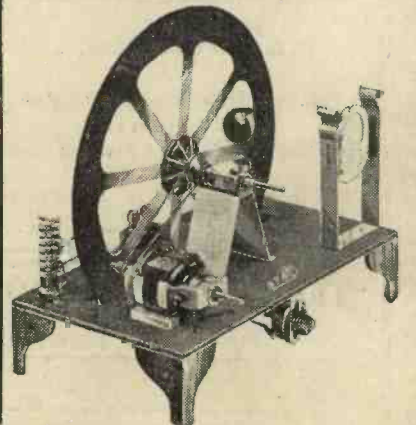

LOOK-IN NOW—with the best 30-line Disc Receiver

THE B.T.S. DISC TELEVISION KIT comprises EVERY PART for instant assembly, including B.T.S. Universal Ball-bearing Television Motor for either Mains or Battery operation as required; controlling resistances; laminated and ready-assembled chassis, with all component fixing holes marked. Stroboscopic 16 in. Scanning disc and stand; lens and lens-holder; improved type TELELUX Neon Lamp and Holder. FULL-SIZE BLUE PRINT WITH ASSEMBLY, WIRING AND OPERATING INSTRUCTIONS WITH EVERY KIT. TYPE K12 for A.C. (40-60 cycles) and D.C. Mains **84/-**
TYPE K13 for 6-volt Battery 78s. If required with B.T.S. Synchronising Gear, 27s. 6d. extra

Send for latest lists of B.T.S. Television and Short Wave Kits and Components.

BRITISH TELEVISION SUPPLIES LTD. BUSH HOUSE, LONDON, W.C.2

Telephone: TEMPLE BAR 0134

WHOLESALE STOCKISTS: J. Dyson & Co., Godwin Street, Bradford. Samuel Gratrix, Jr., & Bros., Ltd., Alport Works, Quay Street, Deansgate, Manchester. Boynton's & Co., Ltd., 65-8, Stafford Street, Birmingham. Nottingham Radio Supplies, Ltd., Sherwood Buildings, Sherwood Street, Nottingham. T. Beadle & Co., Ltd., 3, 4 & 5, Castle Street, Hull. Telegrams: TELEVIEW, BUSH, LONDON